

PROGRAMMABLE WORK POSITIONER

Ergo Control

ERGOTRONIX



Description

A unique 3-axis programmable work positioner that provides full position flexibility to manage any job, including heavy, large and awkwardly shaped objects.

Application

Ergo Control is ideal for secure positioning of any object for any project, no matter what size or shape. This programmable work positioner offers unlimited applications in any industry and is advantageous in any shop floor or work area.

Ergonomic Benefit

- Eliminate employee strain, fatigue and injury.
- Create a safer and more productive work environment.
- Allow easy access and worker comfort for any job.

Standard Features

- Offers full flexibility to move work to any work positions.
- Adaptable to any work fixtures.
- Always ensures the correct work sequence.
- Easy to program via handheld pendant and to operate via foot pedal. Each time the foot pedal is pressed the work piece is moved to the next programmed position.
- Large program capacity for storage of operations to suit each individual operator and application.
- The "L" shaped rotational arm allows easy access to any work surface, including upside down, in a comfortable work position.
- Unlimited rotation on Y + Z axes .
- Easy to program with quick and easy downloading of any stored program (100 programs). Move to desired position and press the programming button. The position is stored in memory. Repeat the procedure to the last position in the work sequence.
- Short set up time.
- Available in 5 standard load classes: 660, 1650, 3300, 6600 and 13,300 lbs.

Options

- Pneumatic supply is provided through arm to the top of the turntable. Used for clamping of fixture, etc.
- Hand Control (including security module) allows motion to be changed from hand instead of foot pedal.
- Dual Arm expands attachment alternatives.
- External speed and directional rotation of turn table (Z-Axis) in programmed position. Useful for welding, etc.
- Micro Switches allow motion to be changed directly from the weld gun instead of using foot pedal.
- Programmable Laser Scanner is placed in front of machine to stop machine if the operator is within programmed safety field.
- ErgoCam allows downloading of machine programs into any Windows based computer for back-up storage.

Application Examples



Solutions

CONVEYANDTRANSFER • LIFT • LIFTANDTRANSPORT • POSITION

TECHNICAL INFORMATION

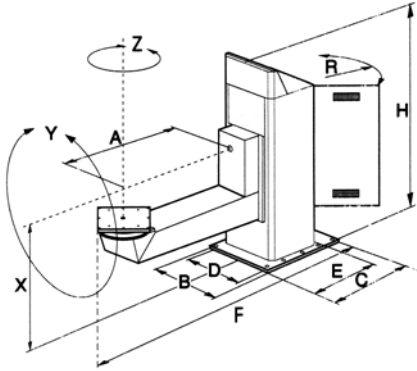

Features	Model 300E	Model 750E	Model 1500E	Model 3000E	Model 6000E
Max. load 3-axis	660 lbs.	1650 lbs.	3300 lbs.	6600 lbs.	13,300 lbs.
Max. load 2-axis	1100 lbs.	2200 lbs.	4400 lbs.	8800 lbs.	17,600 lbs.
A. Arm length	25.6"	39.4"	55.1"	55.1"	86.7"
B. Base width	28"	33.7"	37.8"	65.4"	59.6"
C. Base depth	37.4"	43.3"	51.1"	54.4"	67.0"
D. Width	21.9"	28"	31.7"	35.7"	51.0"
E. Depth	26.2"	32.5"	36.8"	43.9"	42.6"
F. Total depth	76.8"	101.6"	130.7"	134.6"	185.8"
H. Max height	74"	94.9"	94.9"	102.7"	125.7"
R. Rear cabinet	22"	27.6"	31.3"	31.3"	48.9"
X - Vertical travel	21.3-52.5"	28.3-69.5"	26.6-66.7"	32.2-73"	37-83"
Y - Rotation	unlimited	unlimited	unlimited	unlimited	unlimited
Z - Rotation	unlimited	unlimited	unlimited	unlimited	unlimited
Lifting speed X	4.9"/sec.	2.3"/sec.	4.6"/sec.	2.3"/sec.	1.6"/sec.
Rotation speed Y	6.5 rpm	3.5 rpm	2.7 rpm	2.7 rpm	1.6 rpm
Rotation speed Z	6.5 rpm	4.8 rpm	2.7 rpm	2.7 rpm	2.7 rpm
Motor effect total kW/A	2.25/16	4.5/25	7.4/25	8.2/25	10.7/25
Grounding connector	400A	400A	400A	400A	400A
Teach-in programming	yes	yes	yes	yes	yes
Unit Weight	2350 lbs.	3100 lbs.	4000 lbs.	6600 lbs.	14,100 lbs.

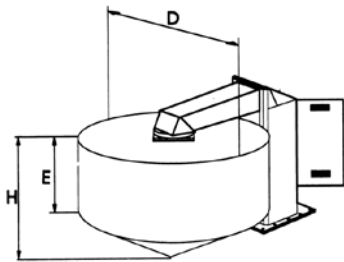

Workpiece vs. Arm Length

Model Dimensions	Model 300E3	Model 750E3	Model 1500E3	Model 3000E3	Model 6000E3
D	51.2"	78.7"	110.2"	110.2"	173.4"
E	50.8"	66.5"	49.6"	49.6"	46.5"
H	57.7"	78.7"	78.7"	78.7"	94.5"

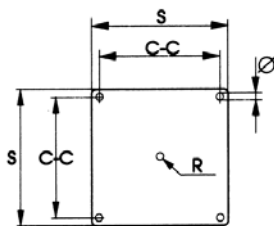

Fixture Mounting Plate

Model Dimensions	Model 300E3	Model 750E3	Model 1500E3	Model 3000E3	Model 6000E3
S	13.8"	19.7"	20.5"	20.5"	31.5"
C-C	12.6"	17.3"	17.3"	17.3"	28.4"
O	0.7"	1.0"	1.0"	1.0"	1.2"
R	1/2"	1/2"	1/2"	1/2"	1/2"

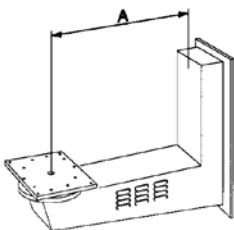

Extended Arm Length (A)

Model Alt.	Model 300E3	Model 750E3	Model 1500E3	Model 3000E3
1	33.5"	47.2"	70.9"	70.9"
2	39.4"	55.1"	78.7"	78.7"

Industrial Ergonomics®

612-532-6774

sales@Industrial-Ergonomics.com

