

MOTORIZED HEAVY-DUTY WORK POSITIONER

Ergo Force®

ERGOTRONIX



Description

This versatile 3-axis work positioner enables movement of work to any suitable work position.

Application

Ergo Force is ideal for secure positioning of any object for any project, no matter what size or shape. This motorized work positioner offers unlimited applications in any industry and is advantageous in any shop or work area.

Ergonomic Benefit

- Eliminate employee strain, fatigue and injury.
- Create a safer and more productive work environment.
- Allows easy access and worker comfort for any job.

Standard Features

- Designed and built in the USA for the most robust and heavy-duty applications.
- Offers full flexibility to move work to any suitable work position.
- The “L” shaped rotational arm allows easy access to work, comfortably and safely.
- Adaptable to any work fixtures.
- Up, down, tilt and rotation controlled by handheld pendant.
- Safety is assured through foot pedal interlock.
- Manage loads up to 600 lbs.
- Unlimited rotation on Y and Z axes.

Options

- Programmable Laser Scanner is placed in front of machine to stop machine if the operator is within programmed safety field.
- Pneumatic output (for fixture safety lock) in center of turntable.
- Weld ground.
- Turntable rotation from separate foot pedal.
- Safety interlock from fixture.



Solutions

CONVEY AND TRANSFER • LIFT • LIFT AND TRANSPORT • POSITION

TECHNICAL INFORMATION

Model	Max. Load	Arm Length	Base Width	Base Depth	Width	Max. Height	Vertical Travel	Lifting Speed	Y Torque	Rotation Speed Y	Z Torque	Rotation Speed Z	Voltage	Unit Weight
EF600-M3-110	600 lbs.	30"	28"	40"	23"	73"	25"-49"	1.4"/sec.	750 ft lbs	0-4 RPM	350 ft lbs	0-4 RPM	110 VAC	1100 lbs.
EF600-M3-208	600 lbs.	30"	28"	40"	23"	73"	25"-49"	1.4"/sec.	750 ft lbs	0-4 RPM	350 ft lbs	0-4 RPM	208V/3PH	1100 lbs.
EF600-M2-110	1000 lbs.	-	28"	40"	23"	73"	25"-49"	1.4"/sec.	750 ft lbs	0-4 RPM	-	-	110 VAC	900 lbs.
EF600-M2-208	1000 lbs.	-	28"	40"	23"	73"	25"-49"	1.4"/sec.	750 ft lbs	0-4 RPM	-	-	208V/3PH	900 lbs.

2 - Axis Ergo Force

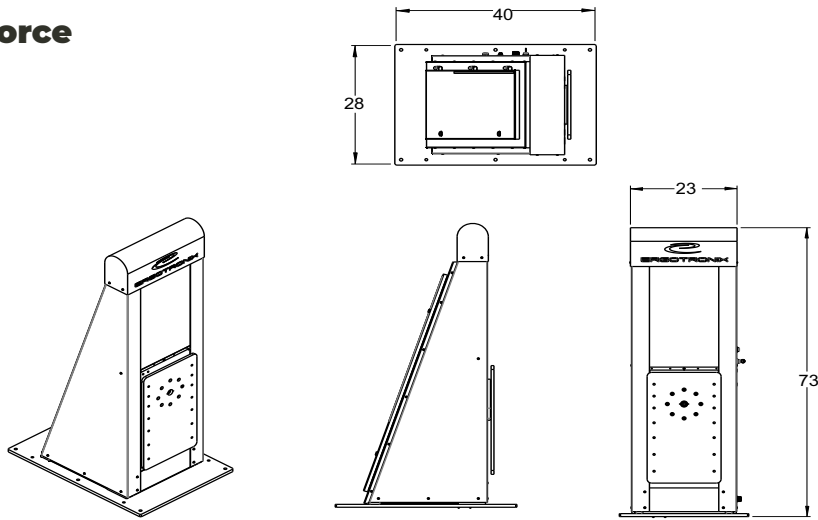

3 - Axis Ergo Force

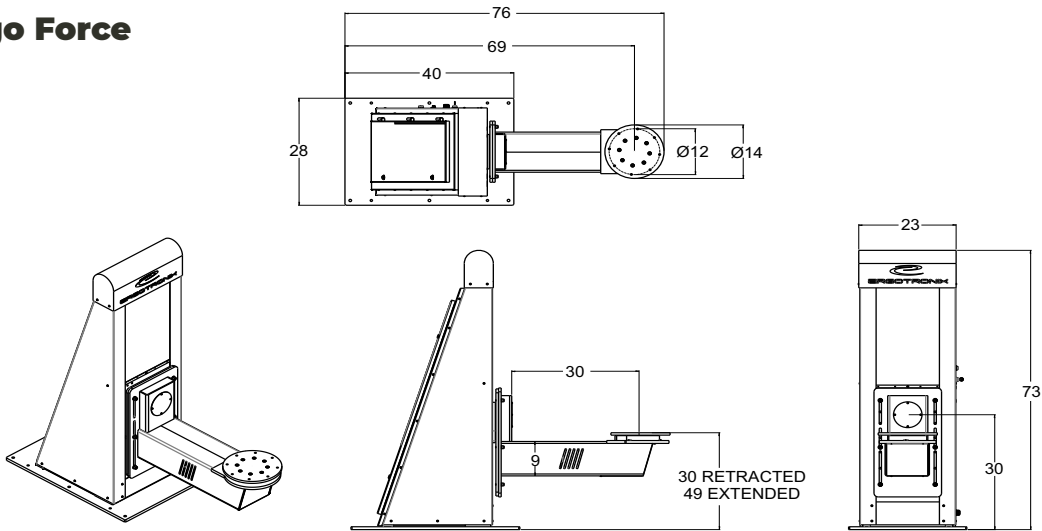

Industrial Ergonomics®

612-532-6774

sales@Industrial-Ergonomics.com

