

LISTA®

INDUSTRIAL ERGONOMICS®
PO BOX 518 LAKEVILLE, MN 55044-0518
(952) 933-7187 FAX (952) 997-6706
E-MAIL: Sales@Industrial-Ergonomics.com
www.Industrial-Ergonomics.com



PRODUCT CATALOG

Complete Storage & Workspace Solutions

ABOUT LISTA®

LISTA provides today's most complete selection of workbenches, cabinets, workspace furniture, accessories, and more. We help you create work environments that:

- Improve productivity
- Benefit the user through smart ergonomic design
- Offer unmatched flexibility
- Are attractive and comfortable

The result of high-quality construction, and innovative engineering and design, LISTA products are built to provide functionality, flexibility, and ease of use in the most demanding working environments.

A custom solution without a custom price, LISTA offers the following consulting services:

DESIGN:

LISTA engineering and design team is ready to provide you with a detailed plan for your individual workspace, cabinet, and storage needs, free of charge.

We offer solutions that are designed for maximum efficiency and future flexibility, optimizing space and profitability.

FLOORSPACE UTILIZATION ANALYSIS:

We can prepare CAD drawings of site plans and elevations for a grouping of products, or entire room-sized solutions.

CUSTOMIZED SURVEYS AND LAYOUTS:

LISTA experts will survey your current and future storage and workspace needs, and propose solutions that provide the highest density and greatest productivity.

INTEGRATION WITH ARCHITECTURAL & CONSTRUCTION PLANNING:

Rely on our experience coordinating with architectural and construction professionals at any stage of a project's development.

UNMATCHED CUSTOMER SUPPORT:

LISTA has knowledgeable, helpful resellers throughout North America. No matter where you are, their guidance and support is always close at hand.

PRICE QUOTES:

We provide free estimates and price quotes for any project, regardless of size.

LISTA®

LISTA®: Table of Contents

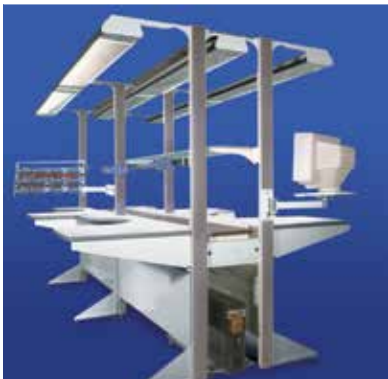

LISTA®

- Introduction A
- Table of Contents 1
- Value Proposition 2

CABINETS

- Preconfigured Shallow Depth Cabinets 6
- Drawer Interiors (Shallow Depth) 32
- Preconfigured Full Depth Cabinets 40
- Drawer Interiors (Full Depth) 66
- Shelf Cabinets 76
- How to Build 78
- Mobile Cabinets 94
- Technician Series Toolboxes 110

NC TOOL STORAGE

- NC Tool Storage 124
- Tool Holders 125
- Workbenches & Cabinets 128

STORAGE WALL

- Storage Wall 138
- How to Configure 141
- Full Depth Storage Wall 142
- Shallow Depth Storage Wall 144
- Accessories 146

SPECIALTY STORAGE

- Shelf Converter 152
- Computer Cabinets 154
- Control Stations 156
- Sink Cabinets 158
- Mezzanine 159

WORKBENCHES

- Preconfigured Industrial 162
- Industrial 170
- Preconfigured Technical 177
- Technical 181
- Arlink 7000 188
- VSI-8 196
- Arlink 8000 198
- Universal Accessories 208
- Align 222
- Nexus 230

ACCESSORIES, SEATING & PAINT

- Drawer Accessories 262
- Seating 274
- Paint Finishes 281

Value Proposition

You know when something possesses the superior quality you demand. It's an excellence you can see and feel—in the steady, effortless glide of every storage drawer; in the solid “click” of highly engineered and durable components; in the handsome gleam of color and finish. Lista's attention to detail produces advanced levels of design, aesthetic, and manufacturing excellence that are unmatched by any other storage or workspace solution provider.

NO COMPROMISES. THAT'S THE LISTA DIFFERENCE.

The Centerpiece of Our Systems

Lista drawers are the centerpieces of our modular building block system and are the perfect combination of durability, configurability, quality, and a professional appearance.

Lista drawers offer the following benefits:

- Complete organization of tools, components, or instrumentation, right at the point of use
- Smoother, quieter performance and impressive cycle life through an advanced drawer suspension system
- Maximized use of cubic capacity for improved space utilization
- The option of sub-dividable capabilities
- Fully customizable
- ISO 9001 certified



Value Proposition



CABINETS

p.6-121



Person working at a workstation in the background.

Drawer containing red packages of TITRO.

Drawer containing red packages of TITRO.

Ordering a Preconfigured Lista cabinet or mobile cabinet takes just a few simple steps, and enables you to have a customized cabinet (down to the base, lock and paint color) without having to break a sweat.

STEPS TO ORDER A PRECONFIGURED SHALLOW DEPTH CABINET



1 Select a cabinet part number:
If you want to include drawer interior sets in your preconfigured cabinet, select the part number with the "A."

PART NO.	DRWS.	COMPARTS.
NS0600-0301N- <input checked="" type="checkbox"/> <input checked="" type="checkbox"/> <input type="checkbox"/>	3	8
NS0600-0301NA- <input checked="" type="checkbox"/> <input checked="" type="checkbox"/> <input type="checkbox"/>	3	8

2 Select base type **3 Select lock type** **4 Select paint color**

- | | | |
|--|--|---|
| <input checked="" type="checkbox"/> Select base type | <input checked="" type="checkbox"/> Select lock type | <input type="checkbox"/> Select paint color |
| NB= No Base | NL= No Lock | BE=Beige |
| 2LB= 2" Leveling Base | RG= Individual | BB=Bright Blue |
| 4LB= 4" Leveling Base | KA= Keyed-alike | BK=Black |
| 6LB= 6" Leveling Base | MA= Master | CB=Classic Blue |
| FT = Fork Truck Base | KP = Keypad Lock | GR=Dark Gray |
| 2FB = 2" Frame Base | | GG=Green |
| 4FB = 4" Frame Base | | LG=Light Gray |
| 6FB = 6" Frame Base | | NR=Red |
| | | SN=Sand |
| | | FW=White |

To see Footprints go to page 80-81.



HS cabinets with stainless steel counter top.



High-density HS drawers.



Mobile ST cabinets are versatile toolboxes.

MODEL 600 SHALLOW DEPTH CABINET COMBINATIONS (22.5" DEEP X 27.5" HEIGHT)

■ Select: Base ■ Select: Lock □ Select: Color

See page 6 for details.

		Cabinet Width	NS-16.85" Wide	CL-22.20" Wide	ST-28.23" Wide
5" 5" 11"		Drawer Capacities	165 lbs. (75kg)	440 lbs. (200kg)	440 lbs. (200kg)
		Drawers Usable Ht. (Points)	NS	CL	ST
		5.12" (150) 5.12" (150) 11.09" (300)	NSDR105-150 NSDR105-150 File	CLDR206-150 CLDR206-150 CLDR104-300	SDR206-150 SDR206-150 SDR104-300
		Cabinets			
		Without interiors	NS0600-0301N-■□	CL0600-0301F-■□	ST0600-0301F-■□
		With Interiors	NS0600-0301NA-■□	CL0600-0301FA-■□	ST0600-0301FA-■□
2" 3" 4" 11"		Drawers Usable Ht. (Points)	NS	CL	ST
		2.17" (75) 3.15" (100) 4.13" (125) 11.02" (300)	NSDR006-75 NSDR104-100 NSDR104-100 NSDR105-300	CLDR312-75 CLDR209-100 CLDR206-100 CLDR104-300	SDR316-75 SDR209-100 SDR104-100
		Cabinets			
		Without interiors	NS0600-0401N-■□	CL0600-0401F-■□	ST0600-0401F-■□
		With Interiors	NS0600-0401NA-■□	CL0600-0401FA-■□	ST0600-0401FA-■□
3" 5" 5" 7"		Drawers Usable Ht. (Points)	NS	CL	ST
		3.15" (100) 5.12" (150) 5.12" (150) 7.09" (200)	NSDR105-100 NSDR105-150 NSDR105-150 NSDR105-200	CLDR209-100 CLDR209-150 CLDR209-150 CLDR209-200	SDR316-100 SDR209-150 SDR104-150 SDR104-200
		Cabinets			
		Without interiors	NS0600-0402N-■□	CL0600-0402F-■□	ST0600-0402F-■□
		With Interiors	NS0600-0402NA-■□	CL0600-0402FA-■□	ST0600-0402FA-■□
2" 2" 3" 5" 7"		Drawers Usable Ht. (Points)	NS	CL	ST
		2.17" (75) 2.17" (75) 3.15" (100) 5.12" (150) 7.09" (200)	NSDR105-75 NSDR105-75 NSDR105-100 NSDR105-150 NSDR105-200	CLDR312-75 CLDR312-75 CLDR209-100 CLDR206-150 CLDR104-200	STDR518-75 STDR308-75 STDR308-100 STDR206-150 STDR206-200
		Cabinets			
		Without interiors	NS0600-0501N-■□	CL0600-0501F-■□	ST0600-0501F-■□
		With Interiors	NS0600-0501NA-■□	CL0600-0501FA-■□	ST0600-0501FA-■□

See pages 32-39 for drawer layout detail.

ES-34.25" Wide	HS-40.28" Wide	MS-46.97" Wide	HT-56.34" Wide
440 lbs. (200kg)	440 lbs. (200kg)	440 lbs. (200kg)	440 lbs. (200kg)
ES	HS	MS	HT
ESDR207-150 ESDR-LR207-150 ESDR104-300	HSDR312-150 HSDR312-150 HSDR-LR106-300	MSDR310-150 MSDR310-150 MSDR207-300	HTDR-LR312-150 HTDR-LR209-150 HTDR-LR106-300
ES0600-0301F- <input type="checkbox"/> <input type="checkbox"/> <input type="checkbox"/> ES0600-0301FA- <input type="checkbox"/> <input type="checkbox"/> <input type="checkbox"/>	HS0600-0301F- <input type="checkbox"/> <input type="checkbox"/> <input type="checkbox"/> HS0600-0301FA- <input type="checkbox"/> <input type="checkbox"/> <input type="checkbox"/>	MS0600-0301F- <input type="checkbox"/> <input type="checkbox"/> <input type="checkbox"/> MS0600-0301FA- <input type="checkbox"/> <input type="checkbox"/> <input type="checkbox"/>	HT0600-0301F- <input type="checkbox"/> <input type="checkbox"/> <input type="checkbox"/> HT0600-0301FA- <input type="checkbox"/> <input type="checkbox"/> <input type="checkbox"/>
ES	HS	MS	HT
ESDR015-75 ESDR312-100 ESDR209-100 ESDR207-300	HDR204-75 HDR312-100 HDR-LR312-100 HDR-LR106-300	MSDR621-75 MSDR518-100 MSDR518-100 MSDR207-300	HTDR-LR415-75 HTDR-LR209-100 HTDR-LR209-100 HTDR-LR106-300
ES0600-0401F- <input type="checkbox"/> <input type="checkbox"/> <input type="checkbox"/> ES0600-0401FA- <input type="checkbox"/> <input type="checkbox"/> <input type="checkbox"/>	HS0600-0401F- <input type="checkbox"/> <input type="checkbox"/> <input type="checkbox"/> HS0600-0401FA- <input type="checkbox"/> <input type="checkbox"/> <input type="checkbox"/>	MS0600-0401F- <input type="checkbox"/> <input type="checkbox"/> <input type="checkbox"/> MS0600-0401FA- <input type="checkbox"/> <input type="checkbox"/> <input type="checkbox"/>	HT0600-0401F- <input type="checkbox"/> <input type="checkbox"/> <input type="checkbox"/> HT0600-0401FA- <input type="checkbox"/> <input type="checkbox"/> <input type="checkbox"/>
ES	HS	MS	HT
ESDR-LR312-100 ESDR-LR209-150 ESDR-LR207-150 ESDR207-200	HDR621-100 HDR312-150 HDR312-150 HDR206-200	MSDR415-100 MSDR312-150 MSDR312-150 MSDR-LR209-200	HTDR-LR312-100 HTDR-LR209-150 HTDR-LR209-150 HTDR-LR106-200
ES0600-0402F- <input type="checkbox"/> <input type="checkbox"/> <input type="checkbox"/> ES0600-0402FA- <input type="checkbox"/> <input type="checkbox"/> <input type="checkbox"/>	HS0600-0402F- <input type="checkbox"/> <input type="checkbox"/> <input type="checkbox"/> HS0600-0402FA- <input type="checkbox"/> <input type="checkbox"/> <input type="checkbox"/>	MS0600-0402F- <input type="checkbox"/> <input type="checkbox"/> <input type="checkbox"/> MS0600-0402FA- <input type="checkbox"/> <input type="checkbox"/> <input type="checkbox"/>	HT0600-0402F- <input type="checkbox"/> <input type="checkbox"/> <input type="checkbox"/> HT0600-0402FA- <input type="checkbox"/> <input type="checkbox"/> <input type="checkbox"/>
ES	HS	MS	HT
ESDR621-75 ESDR-LR209-75 ESDR518-100 ESDR312-150 ESDR-LR207-200	HDR617-75 HDR-LR312-75 HDR518-100 HDR312-150 HDR-LR106-200	MSDR-LR312-75 MSDR-LR312-75 MSDR-LR210-100 MSDR207-150 MSDR207-200	HTDR518-75 HTDR-LR415-75 HTDR-LR312-100 HTDR-LR209-150 HTDR-LR106-200
ES0600-0501F- <input type="checkbox"/> <input type="checkbox"/> <input type="checkbox"/> ES0600-0501FA- <input type="checkbox"/> <input type="checkbox"/> <input type="checkbox"/>	HS0600-0501F- <input type="checkbox"/> <input type="checkbox"/> <input type="checkbox"/> HS0600-0501FA- <input type="checkbox"/> <input type="checkbox"/> <input type="checkbox"/>	MS0600-0501F- <input type="checkbox"/> <input type="checkbox"/> <input type="checkbox"/> MS0600-0501FA- <input type="checkbox"/> <input type="checkbox"/> <input type="checkbox"/>	HT0600-0501F- <input type="checkbox"/> <input type="checkbox"/> <input type="checkbox"/> HT0600-0501FA- <input type="checkbox"/> <input type="checkbox"/> <input type="checkbox"/>

Model 600 Cabinet Combinations continued on next page.

MODEL 600 SHALLOW DEPTH CABINET COMBINATIONS (22.5" DEEP X 27.5" HEIGHT)

■ Select: Base ■ Select: Lock □ Select: Color

See page 6 for details.

		Cabinet Width	NS-16.85" Wide	CL-22.20" Wide	ST-28.23" Wide
 <p>0600-0502</p>	Drawer Capacities		165 lbs. (75kg)	440 lbs. (200kg)	440 lbs. (200kg)
	Drawers Usable Ht. (Points)		NS	CL	ST
	3"	3.15" (100)	NSDR012-100	CLDR209-100	SDR316-100
	3"	3.15" (100)	NSDR104-100	CLDR209-100	SDR209-100
	3"	3.15" (100)	NSDR104-100	CLDR209-100	SDR209-100
	5"	5.12" (150)	NSDR206-150	CLDR206-150	SDR104-150
	5"	5.12" (150)	NSDR209-150	CLDR206-150	SDR104-150
Cabinets					
Without interiors		NS0600-0502N- <input type="checkbox"/> <input type="checkbox"/> <input type="checkbox"/>	CL0600-0502F- <input type="checkbox"/> <input type="checkbox"/> <input type="checkbox"/>	ST0600-0502F- <input type="checkbox"/> <input type="checkbox"/> <input type="checkbox"/>	
With Interiors		NS0600-0502NA- <input type="checkbox"/> <input type="checkbox"/> <input type="checkbox"/>	CL0600-0502FA- <input type="checkbox"/> <input type="checkbox"/> <input type="checkbox"/>	ST0600-0502FA- <input type="checkbox"/> <input type="checkbox"/> <input type="checkbox"/>	
 <p>0600-0601</p>	Drawers Usable Ht. (Points)		NS	CL	ST
	2"	2.17" (75)	NSDR024-75	CLDR312-75	SDR308-75
	2"	2.17" (75)	NSDR006-75	CLDR312-75	SDR420-75
	3"	3.15" (100)	NSDR105-100	CLDR209-100	SDR420-100
	3"	3.15" (100)	NSDR105-100	CLDR209-100	SDR209-100
	3"	3.15" (100)	NSDR104-100	CLDR209-100	SDR209-100
	5"	5.12" (150)	NSDR102-150	CLDR206-150	SDR104-150
Cabinets					
Without interiors		NS0600-0601N- <input type="checkbox"/> <input type="checkbox"/> <input type="checkbox"/>	CL0600-0601F- <input type="checkbox"/> <input type="checkbox"/> <input type="checkbox"/>	ST0600-0601F- <input type="checkbox"/> <input type="checkbox"/> <input type="checkbox"/>	
With Interiors		NS0600-0601NA- <input type="checkbox"/> <input type="checkbox"/> <input type="checkbox"/>	CL0600-0601FA- <input type="checkbox"/> <input type="checkbox"/> <input type="checkbox"/>	ST0600-0601FA- <input type="checkbox"/> <input type="checkbox"/> <input type="checkbox"/>	
 <p>0600-0701</p>	Drawers Usable Ht. (Points)		NS	CL	ST
	2"	2.17" (75)	NSDR105-75	CLDR312-75	SDR316-75
	2"	2.17" (75)	NSDR105-75	CLDR312-75	SDR316-75
	2"	2.17" (75)	NSDR106-75	CLDR312-75	SDR209-75
	2"	2.17" (75)	NSDR106-75	CLDR312-75	SDR209-75
	3"	3.15" (100)	NSDR105-100	CLDR209-100	SDR209-100
	3"	3.15" (100)	NSDR106-100	CLDR209-100	SDR209-100
3"	3.15" (100)	NSDR106-100	CLDR209-100	SDR209-100	
Cabinets					
Without interiors		NS0600-0701N- <input type="checkbox"/> <input type="checkbox"/> <input type="checkbox"/>	CL0600-0701F- <input type="checkbox"/> <input type="checkbox"/> <input type="checkbox"/>	ST0600-0701F- <input type="checkbox"/> <input type="checkbox"/> <input type="checkbox"/>	
With Interiors		NS0600-0701NA- <input type="checkbox"/> <input type="checkbox"/> <input type="checkbox"/>	CL0600-0701FA- <input type="checkbox"/> <input type="checkbox"/> <input type="checkbox"/>	ST0600-0701FA- <input type="checkbox"/> <input type="checkbox"/> <input type="checkbox"/>	
 <p>0600-0703</p>	Drawers Usable Ht. (Points)		NS	CL	ST
	2"	2.17" (75)	NSDR063-75	CLDR009-75	SDR032-75
	2"	2.17" (75)	NSDR020-75	CLDR420-75	SDR020-75
	2"	2.17" (75)	NSDR209-75	CLDR312-75	SDR518-75
	2"	2.17" (75)	NSDR209-75	CLDR312-75	SDR420-75
	2"	2.17" (75)	NSDR106-75	CLDR209-75	SDR106-75
	5"	2.17" (75)	NSDR106-75	CLDR209-75	SDR106-75
5"	5.12" (150)	NSDR-LR203-150	CLDR104-150	SDR206-150	
Cabinets					
Without interiors		NS0600-0703N- <input type="checkbox"/> <input type="checkbox"/> <input type="checkbox"/>	CL0600-0703F- <input type="checkbox"/> <input type="checkbox"/> <input type="checkbox"/>	ST0600-0703F- <input type="checkbox"/> <input type="checkbox"/> <input type="checkbox"/>	
With Interiors		NS0600-0703NA- <input type="checkbox"/> <input type="checkbox"/> <input type="checkbox"/>	CL0600-0703FA- <input type="checkbox"/> <input type="checkbox"/> <input type="checkbox"/>	ST0600-0703FA- <input type="checkbox"/> <input type="checkbox"/> <input type="checkbox"/>	

See pages 32-39 for drawer layout detail.

ES-34.25" Wide	HS-40.28" Wide	MS-46.97" Wide	HT-56.34" Wide
440 lbs. (200kg)	440 lbs. (200kg)	440 lbs. (200kg)	440 lbs. (200kg)
ES	HS	MS	HT
ESDR-LR312-100 ESDR-LR209-100 ESDR-LR207-100 ESDR207-150 ESDR207-150	HDR617-100 HDR415-100 HDR-LR207-100 HDR206-150 HDR206-150	MSDR312-100 MSDR312-100 MSDR312-100 MSDR207-150 MSDR207-150	HTDR-LR312-100 HTDR-LR312-100 HTDR-LR312-100 HTDR-LR209-150 HTDR-LR106-150
ES0600-0502F- <input type="checkbox"/> <input type="checkbox"/> <input type="checkbox"/> ES0600-0502FA- <input type="checkbox"/> <input type="checkbox"/> <input type="checkbox"/>	HS0600-0502F- <input type="checkbox"/> <input type="checkbox"/> <input type="checkbox"/> HS0600-0502FA- <input type="checkbox"/> <input type="checkbox"/> <input type="checkbox"/>	MS0600-0502F- <input type="checkbox"/> <input type="checkbox"/> <input type="checkbox"/> MS0600-0502FA- <input type="checkbox"/> <input type="checkbox"/> <input type="checkbox"/>	HT0600-0502F- <input type="checkbox"/> <input type="checkbox"/> <input type="checkbox"/> HT0600-0502FA- <input type="checkbox"/> <input type="checkbox"/> <input type="checkbox"/>
ES	HS	MS	HT
ESDR310-75 ESDR310-75 ESDR207-100 ESDR207-100 ESDR207-100 ESDR-LR209-150	HDR518-75 HDR-LR312-75 HDR312-100 HDR312-100 HDR312-100 HDR206-150	MSDR518-75 MSDR415-75 MSDR415-100 MSDR312-100 MSDR312-100 MSDR207-150	HTDR-LR209-75 HTDR-LR415-75 HTDR-LR415-100 HTDR-LR312-100 HTDR-LR312-100 HTDR-LR209-150
ES0600-0601F- <input type="checkbox"/> <input type="checkbox"/> <input type="checkbox"/> ES0600-0601FA- <input type="checkbox"/> <input type="checkbox"/> <input type="checkbox"/>	HS0600-0601F- <input type="checkbox"/> <input type="checkbox"/> <input type="checkbox"/> HS0600-0601FA- <input type="checkbox"/> <input type="checkbox"/> <input type="checkbox"/>	MS0600-0601F- <input type="checkbox"/> <input type="checkbox"/> <input type="checkbox"/> MS0600-0601FA- <input type="checkbox"/> <input type="checkbox"/> <input type="checkbox"/>	HT0600-0601F- <input type="checkbox"/> <input type="checkbox"/> <input type="checkbox"/> HT0600-0601FA- <input type="checkbox"/> <input type="checkbox"/> <input type="checkbox"/>
ES	HS	MS	HT
ESDR518-75 ESDR518-75 ESDR415-75 ESDR415-75 ESDR312-100 ESDR312-100 ESDR312-100	HDR621-75 HDR621-75 HDR518-75 HDR518-75 HDR415-100 HDR415-100 HDR415-100	MSDR-LR209-75 MSDR-LR209-75 MSDR207-75 MSDR207-75 MSDR-LR312-100 MSDR-LR312-100 MSDR-LR312-100	HTDR-LR415-75 HTDR-LR312-75 HTDR-LR312-75 HTDR-LR209-75 HTDR-LR209-100 HTDR-LR209-100 HTDR-LR209-100
ES0600-0701F- <input type="checkbox"/> <input type="checkbox"/> <input type="checkbox"/> ES0600-0701FA- <input type="checkbox"/> <input type="checkbox"/> <input type="checkbox"/>	HS0600-0701F- <input type="checkbox"/> <input type="checkbox"/> <input type="checkbox"/> HS0600-0701FA- <input type="checkbox"/> <input type="checkbox"/> <input type="checkbox"/>	MS0600-0701F- <input type="checkbox"/> <input type="checkbox"/> <input type="checkbox"/> MS0600-0701FA- <input type="checkbox"/> <input type="checkbox"/> <input type="checkbox"/>	HT0600-0701F- <input type="checkbox"/> <input type="checkbox"/> <input type="checkbox"/> HT0600-0701FA- <input type="checkbox"/> <input type="checkbox"/> <input type="checkbox"/>
ES	HS	MS	HT
ESDR621-75 ESDR621-75 ESDR-LR312-75 ESDR-LR312-75 ESDR415-75 ESDR209-75 ESDR209-150	HDR040-75 HDR024-75 HDR617-75 HDR415-75 HDR206-75 HDR-LR312-75 HDR-LR207-150	MSDR-LR210-75 MSDR-LR210-75 MSDR-LR209-75 MSDR-LR209-75 MSDR207-75 MSDR207-75 MSDR207-150	HTDR518-75 HTDR-LR415-75 HTDR-LR415-75 HTDR-LR312-75 HTDR-LR312-75 HTDR-LR209-75 HTDR-LR209-150
ES0600-0703F- <input type="checkbox"/> <input type="checkbox"/> <input type="checkbox"/> ES0600-0703FA- <input type="checkbox"/> <input type="checkbox"/> <input type="checkbox"/>	HS0600-0703F- <input type="checkbox"/> <input type="checkbox"/> <input type="checkbox"/> HS0600-0703FA- <input type="checkbox"/> <input type="checkbox"/> <input type="checkbox"/>	MS0600-0703F- <input type="checkbox"/> <input type="checkbox"/> <input type="checkbox"/> MS0600-0703FA- <input type="checkbox"/> <input type="checkbox"/> <input type="checkbox"/>	HT0600-0703F- <input type="checkbox"/> <input type="checkbox"/> <input type="checkbox"/> HT0600-0703FA- <input type="checkbox"/> <input type="checkbox"/> <input type="checkbox"/>

MODEL 750 SHALLOW DEPTH CABINET COMBINATIONS (22.5" DEEP X 33.5" HEIGHT)

■ Select: Base ■ Select: Lock □ Select: Color

See page 6 for details.

		Cabinet Width	NS-16.85" Wide	CL-22.20" Wide	ST-28.23" Wide
 5" 5" 7" 9"	Drawer Capacities		165 lbs. (75kg)	440 lbs. (200kg)	440 lbs. (200kg)
	Drawers Usable Ht. (Points)		NS	CL	ST
	5.12" (150)		NSDR104-150	CLDR209-150	SDR106-150
	5.12" (150)		NSDR104-150	CLDR209-150	SDR106-150
	7.09" (200)		NSDR104-200	CLDR104-200	SDR206-200
9.06" (250)		NSDR102-250	CLDR209-250	SDR106-250	
	Cabinets				
Without interiors		NS0750-0401N-■□	CL0750-0401F-■□	ST0750-0401F-■□	
With Interiors		NS0750-0401NA-■□	CL0750-0401FA-■□	ST0750-0401FA-■□	
 3" 5" 7" 11"	Drawers Usable Ht. (Points)		NS	CL	ST
	3.15" (100)		NSDR006-100	CLDR209-100	SDR316-100
	5.12" (150)		NSDR106-150	CLDR206-150	SDR209-150
	7.09" (200)		NSDR104-200	CLDR104-200	SDR104-200
	11.02" (300)		NSDR104-300	CLDR104-300	-
	Cabinets				
Without interiors		NS0750-0402N-■□	CL0750-0402F-■□	ST0750-0402F-■□	
With Interiors		NS0750-0402NA-■□	CL0750-0402FA-■□	ST0750-0402FA-■□	
 5" 7" 7" 7"	Drawers Usable Ht. (Points)		NS	CL	ST
	5.12" (150)		NSDR206-150	CLDR206-150	SDR308-150
	7.09" (200)		NSDR106-200	CLDR104-200	SDR206-200
	7.09" (200)		NSDR104-200	CLDR104-200	SDR106-200
	7.09" (200)		NSDR102-200	CLDR104-200	SDR106-200
	Cabinets				
Without interiors		NS0750-0404N-■□	CL0750-0404F-■□	ST0750-0404F-■□	
With Interiors		NS0750-0404NA-■□	CL0750-0404FA-■□	ST0750-0404FA-■□	
 2" 3" 4" 5" 11"	Drawers Usable Ht. (Points)		NS	CL	ST
	2.17" (75)		NSDR014-75	CLDR415-75	SDR530-75
	3.15" (100)		NSDR008-100	CLDR312-100	SDR420-100
	4.13" (125)		NSDR206-100	CLDR312-100	SDR312-100
	5.12" (150)		NSDR104-150	CLDR206-150	SDR209-150
11.02" (300)		NSDR-LR203-300	CLDR104-300	SDR104-300	
	Cabinets				
Without interiors		NS0750-0501N-■□	CL0750-0501F-■□	ST0750-0501F-■□	
With Interiors		NS0750-0501NA-■□	CL0750-0501FA-■□	ST0750-0501FA-■□	

See pages 32-39 for drawer layout detail.

ES-34.25" Wide	HS-40.28" Wide	MS-46.97" Wide	HT-56.34" Wide
440 lbs. (200kg)	440 lbs. (200kg)	440 lbs. (200kg)	440 lbs. (200kg)
ES	HS	MS	HT
ESDR-LR207-150 ESDR-LR207-150 ESDR-LR209-200 ESDR-LR209-250	HDR312-150 HDR312-150 HDR206-200 HDR-LR106-250	MSDR415-150 MSDR415-150 MSDR-LR209-200 MSDR-LR209-250	HTDR518-150 HTDR518-150 HTDR-LR209-200 HTDR518-250
ES0750-0401F- <input type="checkbox"/> <input type="checkbox"/> <input type="checkbox"/> ES0750-0401FA- <input type="checkbox"/> <input type="checkbox"/> <input type="checkbox"/>	HS0750-0401F- <input type="checkbox"/> <input type="checkbox"/> <input type="checkbox"/> HS0750-0401FA- <input type="checkbox"/> <input type="checkbox"/> <input type="checkbox"/>	MS0750-0401F- <input type="checkbox"/> <input type="checkbox"/> <input type="checkbox"/> MS0750-0401FA- <input type="checkbox"/> <input type="checkbox"/> <input type="checkbox"/>	HT0750-0401F- <input type="checkbox"/> <input type="checkbox"/> <input type="checkbox"/> HT0750-0401FA- <input type="checkbox"/> <input type="checkbox"/> <input type="checkbox"/>
ES	HS	MS	HT
ESDR209-100 ESDR209-150 ESDR207-200 ESDR104-300	HDR-LR312-100 HDR-LR209-150 HDR206-200 HDR-LR106-300	MSDR621-100 MSDR518-150 MSDR518-200 MSDR207-300	HTDR724-100 HTDR621-150 HTDR621-200 HTDR203-300
ES0750-0402F- <input type="checkbox"/> <input type="checkbox"/> <input type="checkbox"/> ES0750-0402FA- <input type="checkbox"/> <input type="checkbox"/> <input type="checkbox"/>	HS0750-0402F- <input type="checkbox"/> <input type="checkbox"/> <input type="checkbox"/> HS0750-0402FA- <input type="checkbox"/> <input type="checkbox"/> <input type="checkbox"/>	MS0750-0402F- <input type="checkbox"/> <input type="checkbox"/> <input type="checkbox"/> MS0750-0402FA- <input type="checkbox"/> <input type="checkbox"/> <input type="checkbox"/>	HT0750-0402F- <input type="checkbox"/> <input type="checkbox"/> <input type="checkbox"/> HT0750-0402FA- <input type="checkbox"/> <input type="checkbox"/> <input type="checkbox"/>
ES	HS	MS	HT
ESDR310-150 ESDR310-200 ESDR312-200 ESDR-LR207-200	HDR-LR207-150 HDR-LR207-200 HDR-LR209-200 HDR-LR209-200	MSDR-LR209-150 MSDR-LR209-200 MSDR-LR210-200 MSDR-LR210-200	HTDR-LR209-150 HTDR-LR209-200 HTDR-LR106-200 HTDR-LR106-200
ES0750-0404F- <input type="checkbox"/> <input type="checkbox"/> <input type="checkbox"/> ES0750-0404FA- <input type="checkbox"/> <input type="checkbox"/> <input type="checkbox"/>	HS0750-0404F- <input type="checkbox"/> <input type="checkbox"/> <input type="checkbox"/> HS0750-0404FA- <input type="checkbox"/> <input type="checkbox"/> <input type="checkbox"/>	MS0750-0404F- <input type="checkbox"/> <input type="checkbox"/> <input type="checkbox"/> MS0750-0404FA- <input type="checkbox"/> <input type="checkbox"/> <input type="checkbox"/>	HT0750-0404F- <input type="checkbox"/> <input type="checkbox"/> <input type="checkbox"/> HT0750-0404FA- <input type="checkbox"/> <input type="checkbox"/> <input type="checkbox"/>
ES	HS	MS	HT
ESDR-LR312-75 ESDR-LR312-100 ESDR-LR209-100 ESDR-LR209-150 -	HDR415-75 HDR312-100 HDR312-100 HDR-LR207-150 HDR-LR106-300	MSDR030-75 MSDR312-100 MSDR312-100 MSDR207-150 MSDR-LR209-300	HTDR415-75 HTDR-LR312-100 HTDR-LR312-100 HTDR-LR209-150 HTDR-LR209-300
ES0750-0501F- <input type="checkbox"/> <input type="checkbox"/> <input type="checkbox"/> ES0750-0501FA- <input type="checkbox"/> <input type="checkbox"/> <input type="checkbox"/>	HS0750-0501F- <input type="checkbox"/> <input type="checkbox"/> <input type="checkbox"/> HS0750-0501FA- <input type="checkbox"/> <input type="checkbox"/> <input type="checkbox"/>	MS0750-0501F- <input type="checkbox"/> <input type="checkbox"/> <input type="checkbox"/> MS0750-0501FA- <input type="checkbox"/> <input type="checkbox"/> <input type="checkbox"/>	HT0750-0501F- <input type="checkbox"/> <input type="checkbox"/> <input type="checkbox"/> HT0750-0501FA- <input type="checkbox"/> <input type="checkbox"/> <input type="checkbox"/>

Model 750 Cabinet Combinations continued on next page.

MODEL 750 SHALLOW DEPTH CABINET COMBINATIONS (22.5" DEEP X 33.5" HEIGHT)

■ Select: Base ■ Select: Lock □ Select: Color

See page 6 for details.

		Cabinet Width	NS-16.85" Wide	CL-22.20" Wide	ST-28.23" Wide
 <p>0750-0502</p>	Drawer Capacities		165 lbs. (75kg)	440 lbs. (200kg)	440 lbs. (200kg)
	Drawers Usable Ht. (Points)		NS	CL	ST
	3"	3.15" (100)	NSDR206-100	CLDR206-100	SDR312-100
	3"	3.15" (100)	NSDR206-100	CLDR206-100	SDR312-100
	5"	5.12" (150)	NSDR105-150	CLDR104-150	SDR104-150
5"	5.12" (150)	NSDR105-150	CLDR104-150	SDR104-150	
9"	9.06" (250)	NSDR104-250	CLDR104-250	SDR104-250	
	Cabinets				
	Without interiors	NS0750-0502N- <input type="checkbox"/> <input type="checkbox"/> <input type="checkbox"/>	CL0750-0502F- <input type="checkbox"/> <input type="checkbox"/> <input type="checkbox"/>	ST0750-0502F- <input type="checkbox"/> <input type="checkbox"/> <input type="checkbox"/>	
	With Interiors	NS0750-0502NA- <input type="checkbox"/> <input type="checkbox"/> <input type="checkbox"/>	CL0750-0502FA- <input type="checkbox"/> <input type="checkbox"/> <input type="checkbox"/>	ST0750-0502FA- <input type="checkbox"/> <input type="checkbox"/> <input type="checkbox"/>	
 <p>0750-0505</p>	Drawers Usable Ht. (Points)		NS	CL	ST
	2"	2.17" (75)	NSDR105-75	CLDR312-75	SDR518-75
	3"	3.15" (100)	NSDR105-100	CLDR209-100	SDR308-100
	4"	4.13" (125)	NSDR105-100	CLDR209-100	SDR308-100
	7"	7.09" (200)	NSDR104-200	CLDR104-200	SDR206-200
9"	9.06" (250)	NSDR104-250	CLDR104-250	SDR104-250	
	Cabinets				
	Without interiors	NS0750-0505N- <input type="checkbox"/> <input type="checkbox"/> <input type="checkbox"/>	CL0750-0505F- <input type="checkbox"/> <input type="checkbox"/> <input type="checkbox"/>	ST0750-0505F- <input type="checkbox"/> <input type="checkbox"/> <input type="checkbox"/>	
	With Interiors	NS0750-0505NA- <input type="checkbox"/> <input type="checkbox"/> <input type="checkbox"/>	CL0750-0505FA- <input type="checkbox"/> <input type="checkbox"/> <input type="checkbox"/>	ST0750-0505FA- <input type="checkbox"/> <input type="checkbox"/> <input type="checkbox"/>	
 <p>0750-0601</p>	Drawers Usable Ht. (Points)		NS	CL	ST
	2"	2.17" (75)	NSDR105-75	CLDR312-75	SDR032-75
	2"	2.17" (75)	NSDR105-75	CLDR312-75	SDR316-75
	3"	3.15" (100)	NSDR105-100	CLDR209-100	SDR209-100
	5"	5.12" (150)	NSDR105-150	CLDR206-150	SDR209-150
5"	5.12" (150)	NSDR105-150	CLDR206-150	SDR104-150	
7"	7.09" (200)	NSDR104-200	CLDR104-200	SDR104-200	
	Cabinets				
	Without interiors	NS0750-0601N- <input type="checkbox"/> <input type="checkbox"/> <input type="checkbox"/>	CL0750-0601F- <input type="checkbox"/> <input type="checkbox"/> <input type="checkbox"/>	ST0750-0601F- <input type="checkbox"/> <input type="checkbox"/> <input type="checkbox"/>	
	With Interiors	NS0750-0601NA- <input type="checkbox"/> <input type="checkbox"/> <input type="checkbox"/>	CL0750-0601FA- <input type="checkbox"/> <input type="checkbox"/> <input type="checkbox"/>	ST0750-0601FA- <input type="checkbox"/> <input type="checkbox"/> <input type="checkbox"/>	
 <p>0750-0602</p>	Drawers Usable Ht. (Points)		NS	CL	ST
	2"	2.17" (75)	NSDR209-75	CLDR312-75	SDR518-75
	2"	2.17" (75)	NSDR209-75	CLDR312-75	SDR518-75
	3"	3.15" (100)	NSDR106-100	CLDR209-100	SDR308-100
	3"	3.15" (100)	NSDR104-100	CLDR209-100	SDR308-100
5"	5.12" (150)	NSDR105-150	CLDR206-150	SDR206-150	
9"	9.06" (250)	NSDR102-250	CLDR104-250	SDR104-250	
	Cabinets				
	Without interiors	NS0750-0602N- <input type="checkbox"/> <input type="checkbox"/> <input type="checkbox"/>	CL0750-0602F- <input type="checkbox"/> <input type="checkbox"/> <input type="checkbox"/>	ST0750-0602F- <input type="checkbox"/> <input type="checkbox"/> <input type="checkbox"/>	
	With Interiors	NS0750-0602NA- <input type="checkbox"/> <input type="checkbox"/> <input type="checkbox"/>	CL0750-0602FA- <input type="checkbox"/> <input type="checkbox"/> <input type="checkbox"/>	ST0750-0602FA- <input type="checkbox"/> <input type="checkbox"/> <input type="checkbox"/>	

See pages 32-39 for drawer layout detail.

ES—34.25" Wide	HS—40.28" Wide	MS—46.97" Wide	HT—56.34" Wide
440 lbs. (200kg)	440 lbs. (200kg)	440 lbs. (200kg)	440 lbs. (200kg)
ES	HS	MS	HT
ESDR415-100 ESDR415-100 ESDR310-150 ESDR310-150 ESDR207-250	HDR621-100 HDR312-100 HDR312-150 HDR206-150 HDR206-250	MSDR724-100 MSDR518-100 MSDR-LR209-150 MSDR-LR209-150 MSDR-LR210-250	HTDR827-100 HTDR621-100 HTDR-LR209-150 HTDR-LR209-150 HTDR-LR106-250
ES0750-0502F- <input type="checkbox"/> <input type="checkbox"/> <input type="checkbox"/> ES0750-0502FA- <input type="checkbox"/> <input type="checkbox"/> <input type="checkbox"/>	HS0750-0502F- <input type="checkbox"/> <input type="checkbox"/> <input type="checkbox"/> HS0750-0502FA- <input type="checkbox"/> <input type="checkbox"/> <input type="checkbox"/>	MS0750-0502F- <input type="checkbox"/> <input type="checkbox"/> <input type="checkbox"/> MS0750-0502FA- <input type="checkbox"/> <input type="checkbox"/> <input type="checkbox"/>	HT0750-0502F- <input type="checkbox"/> <input type="checkbox"/> <input type="checkbox"/> HT0750-0502FA- <input type="checkbox"/> <input type="checkbox"/> <input type="checkbox"/>
ES	HS	MS	HT
ESDR518-75 ESDR-LR312-100 ESDR312-100 ESDR209-200 ESDR209-250	HDR518-75 HDR-LR312-100 HDR312-100 HDR206-200 HDR206-250	MSDR-LR312-75 MSDR-LR312-100 MSDR-LR312-100 MSDR-LR210-200 MSDR-LR210-250	HTDR-LR312-75 HTDR-LR312-100 HTDR-LR312-100 HTDR-LR209-200 HTDR-LR209-250
ES0750-0505F- <input type="checkbox"/> <input type="checkbox"/> <input type="checkbox"/> ES0750-0505FA- <input type="checkbox"/> <input type="checkbox"/> <input type="checkbox"/>	HS0750-0505F- <input type="checkbox"/> <input type="checkbox"/> <input type="checkbox"/> HS0750-0505FA- <input type="checkbox"/> <input type="checkbox"/> <input type="checkbox"/>	MS0750-0505F- <input type="checkbox"/> <input type="checkbox"/> <input type="checkbox"/> MS0750-0505FA- <input type="checkbox"/> <input type="checkbox"/> <input type="checkbox"/>	HT0750-0505F- <input type="checkbox"/> <input type="checkbox"/> <input type="checkbox"/> HT0750-0505FA- <input type="checkbox"/> <input type="checkbox"/> <input type="checkbox"/>
ES	HS	MS	HT
ESDR024-75 ESDR015-75 ESDR310-100 ESDR310-150 ESDR207-150 ESDR207-200	HDR024-75 HDRSG432 HDR415-100 HDR-LR209-150 HDR-LR209-150 HDR206-200	MSDR827-75 MSDR827-75 MSDR621-100 MSDR621-150 MSDR415-150 MSDR415-200	HTDR930-75 HTDR930-75 HTDR724-100 HTDR724-150 HTDR518-150 HTDR518-200
ES0750-0601F- <input type="checkbox"/> <input type="checkbox"/> <input type="checkbox"/> ES0750-0601FA- <input type="checkbox"/> <input type="checkbox"/> <input type="checkbox"/>	HS0750-0601F- <input type="checkbox"/> <input type="checkbox"/> <input type="checkbox"/> HS0750-0601FA- <input type="checkbox"/> <input type="checkbox"/> <input type="checkbox"/>	MS0750-0601F- <input type="checkbox"/> <input type="checkbox"/> <input type="checkbox"/> MS0750-0601FA- <input type="checkbox"/> <input type="checkbox"/> <input type="checkbox"/>	HT0750-0601F- <input type="checkbox"/> <input type="checkbox"/> <input type="checkbox"/> HT0750-0601FA- <input type="checkbox"/> <input type="checkbox"/> <input type="checkbox"/>
ES	HS	MS	HT
ESDR621-75 ESDR-LR312-75 ESDR518-100 ESDR-LR209-100 ESDR312-150 ESDR207-250	HDR617-75 HDR-LR312-75 HDR518-100 HDR-LR209-100 HDR312-150 HDR-LR106-250	MSDR724-75 MSDR-LR312-75 MSDR621-100 MSDR-LR210-100 MSDR415-150 MSDR-LR209-250	HTDR827-75 HTDR-LR312-75 HTDR724-100 HTDR-LR209-100 HTDR518-150 HTDR-LR209-250
ES0750-0602F- <input type="checkbox"/> <input type="checkbox"/> <input type="checkbox"/> ES0750-0602FA- <input type="checkbox"/> <input type="checkbox"/> <input type="checkbox"/>	HS0750-0602F- <input type="checkbox"/> <input type="checkbox"/> <input type="checkbox"/> HS0750-0602FA- <input type="checkbox"/> <input type="checkbox"/> <input type="checkbox"/>	MS0750-0602F- <input type="checkbox"/> <input type="checkbox"/> <input type="checkbox"/> MS0750-0602FA- <input type="checkbox"/> <input type="checkbox"/> <input type="checkbox"/>	HT0750-0602F- <input type="checkbox"/> <input type="checkbox"/> <input type="checkbox"/> HT0750-0602FA- <input type="checkbox"/> <input type="checkbox"/> <input type="checkbox"/>

Model 750 Cabinet Combinations
continued on next page.

MODEL 750 SHALLOW DEPTH CABINET COMBINATIONS (22.5" DEEP X 33.5" HEIGHT)

■ Select: Base ■ Select: Lock □ Select: Color

See page 6 for details.

		Cabinet Width	NS-16.85" Wide	CL-22.20" Wide	ST-28.23" Wide
 <p>0750-0701</p>	Drawer Capacities		165 lbs. (75kg)	440 lbs. (200kg)	440 lbs. (200kg)
	Drawers Usable Ht. (Points)		NS	CL	ST
	2"	2.17" (75)	NSDR063	CLDR312-75	SDR518-75
	2"	2.17" (75)	NSDR006-75	CLDR312-75	SDR518-75
	2"	2.17" (75)	NSDR105-75	CLDR312-75	SDR308-75
	3"	2.17" (75)	NSDR102-75	CLDR312-75	SDR308-75
	5"	3.15" (100)	NSDR104-100	CLDR209-100	SDR308-100
		5.12" (150)	NSDR104-150	CLDR206-150	SDR206-150
		7.09" (200)	NSDR106-200	CLDR104-200	SDR206-200
	Cabinets				
Without interiors		NS0750-0701N- <input type="checkbox"/> <input type="checkbox"/> <input type="checkbox"/>	CL0750-0701F- <input type="checkbox"/> <input type="checkbox"/> <input type="checkbox"/>	ST0750-0701F- <input type="checkbox"/> <input type="checkbox"/> <input type="checkbox"/>	
With Interiors		NS0750-0701NA- <input type="checkbox"/> <input type="checkbox"/> <input type="checkbox"/>	CL0750-0701FA- <input type="checkbox"/> <input type="checkbox"/> <input type="checkbox"/>	ST0750-0701FA- <input type="checkbox"/> <input type="checkbox"/> <input type="checkbox"/>	
 <p>0750-0703</p>	Drawers Usable Ht. (Points)		NS	CL	ST
	2"	2.17" (75)	NSDR105-75	CLDR312-75	SDR420-75
	2"	2.17" (75)	NSDR105-75	CLDR312-75	SDR420-75
	3"	3.15" (100)	NSDR105-100	CLDR209-100	SDR316-100
	3"	3.15" (100)	NSDR105-100	CLDR209-100	SDR316-100
	3"	3.15" (100)	NSDR105-100	CLDR209-100	SDR209-100
	5"	5.12" (150)	NSDR105-150	CLDR206-150	SDR206-150
	5"	5.12" (150)	NSDR105-150	CLDR206-150	SDR104-150
	Cabinets				
	Without interiors		NS0750-0703N- <input type="checkbox"/> <input type="checkbox"/> <input type="checkbox"/>	CL0750-0703F- <input type="checkbox"/> <input type="checkbox"/> <input type="checkbox"/>	ST0750-0703F- <input type="checkbox"/> <input type="checkbox"/> <input type="checkbox"/>
With Interiors		NS0750-0703NA- <input type="checkbox"/> <input type="checkbox"/> <input type="checkbox"/>	CL0750-0703FA- <input type="checkbox"/> <input type="checkbox"/> <input type="checkbox"/>	ST0750-0703FA- <input type="checkbox"/> <input type="checkbox"/> <input type="checkbox"/>	
 <p>0750-0704</p>	Drawers Usable Ht. (Points)		NS	CL	ST
	3"	3.15" (100)	NSDR006-100	CLDR012-100	SDR024-100
	3"	3.15" (100)	NSDR006-100	CLDR009-100	SDR012-100
	3"	3.15" (100)	NSDR209-100	CLDR209-100	SDR312-100
	3"	3.15" (100)	NSDR209-100	CLDR209-100	SDR312-100
	3"	3.15" (100)	NSDR206-100	CLDR206-100	SDR209-100
	3"	3.15" (100)	NSDR206-100	CLDR206-100	SDR209-100
	5"	5.12" (150)	NSDR105-150	CLDR104-150	SDR209-150
	Cabinets				
	Without interiors		NS0750-0704N- <input type="checkbox"/> <input type="checkbox"/> <input type="checkbox"/>	CL0750-0704F- <input type="checkbox"/> <input type="checkbox"/> <input type="checkbox"/>	ST0750-0704F- <input type="checkbox"/> <input type="checkbox"/> <input type="checkbox"/>
With Interiors		NS0750-0704NA- <input type="checkbox"/> <input type="checkbox"/> <input type="checkbox"/>	CL0750-0704FA- <input type="checkbox"/> <input type="checkbox"/> <input type="checkbox"/>	ST0750-0704FA- <input type="checkbox"/> <input type="checkbox"/> <input type="checkbox"/>	
 <p>0750-0801</p>	Drawers Usable Ht. (Points)		NS	CL	ST
	2"	2.17" (75)	NSDR062	CLDR021-75	SDR160-75
	2"	2.17" (75)	NSDR014-75	CLDR018-75	SDR032-75
	2"	2.17" (75)	NSDR104-75	CLDR012-75	SDR012-75
	3"	2.17" (75)	NSDR105-75	CLDR009-75	SDR518-75
	3"	3.15" (100)	NSDR104-100	CLDR209-100	SDR420-100
	3"	3.15" (100)	NSDR104-100	CLDR206-100	SDR316-100
	5"	3.15" (100)	NSDR104-100	CLDR206-100	SDR308-100
		5.12" (150)	NSDR105-150	CLDR104-150	SDR106-150
	Cabinets				
Without interiors		NS0750-0801N- <input type="checkbox"/> <input type="checkbox"/> <input type="checkbox"/>	CL0750-0801F- <input type="checkbox"/> <input type="checkbox"/> <input type="checkbox"/>	ST0750-0801F- <input type="checkbox"/> <input type="checkbox"/> <input type="checkbox"/>	
With Interiors		NS0750-0801NA- <input type="checkbox"/> <input type="checkbox"/> <input type="checkbox"/>	CL0750-0801FA- <input type="checkbox"/> <input type="checkbox"/> <input type="checkbox"/>	ST0750-0801FA- <input type="checkbox"/> <input type="checkbox"/> <input type="checkbox"/>	

See pages 32-39 for drawer layout detail.

ES-34.25" Wide	HS-40.28" Wide	MS-46.97" Wide	HT-56.34" Wide
440 lbs. (200kg)	440 lbs. (200kg)	440 lbs. (200kg)	440 lbs. (200kg)
ES	HS	MS	HT
ESDR518-75 ESDR518-75 ESDR-LR207-75 ESDR-LR207-75 ESDR415-100 ESDR310-150 ESDR-LR209-200	HDR617-75 HDR617-75 HDR-LR312-75 HDR-LR312-75 HDR518-100 HDR312-150 HDR-LR106-200	MSDR724-75 MSDR724-75 MSDR-LR312-75 MSDR-LR312-75 MSDR621-100 MSDR415-150 MSDR-LR209-200	HTDR827-75 HTDR827-75 HTDR-LR312-75 HTDR-LR312-75 HTDR724-100 HTDR518-150 HTDR-LR106-200
ES0750-0701F- <input type="checkbox"/> <input type="checkbox"/> <input type="checkbox"/> ES0750-0701FA- <input type="checkbox"/> <input type="checkbox"/> <input type="checkbox"/>	HS0750-0701F- <input type="checkbox"/> <input type="checkbox"/> <input type="checkbox"/> HS0750-0701FA- <input type="checkbox"/> <input type="checkbox"/> <input type="checkbox"/>	MS0750-0701F- <input type="checkbox"/> <input type="checkbox"/> <input type="checkbox"/> MS0750-0701FA- <input type="checkbox"/> <input type="checkbox"/> <input type="checkbox"/>	HT0750-0701F- <input type="checkbox"/> <input type="checkbox"/> <input type="checkbox"/> HT0750-0701FA- <input type="checkbox"/> <input type="checkbox"/> <input type="checkbox"/>
ES	HS	MS	HT
ESDR518-75 ESDR518-75 ESDR415-100 ESDR415-100 ESDR415-100 ESDR312-150 ESDR312-150	HDR518-75 HDR518-75 HDR415-100 HDR415-100 HDR415-100 HDR312-150 HDR312-150	MSDR415-75 MSDR415-75 MSDR-LR312-100 MSDR-LR312-100 MSDR-LR312-100 MSDR-LR209-150 MSDR-LR209-150	HTDR518-75 HTDR518-75 HTDR-LR312-100 HTDR-LR312-100 HTDR-LR312-100 HTDR-LR209-150 HTDR-LR209-150
ES0750-0703F- <input type="checkbox"/> <input type="checkbox"/> <input type="checkbox"/> ES0750-0703FA- <input type="checkbox"/> <input type="checkbox"/> <input type="checkbox"/>	HS0750-0703F- <input type="checkbox"/> <input type="checkbox"/> <input type="checkbox"/> HS0750-0703FA- <input type="checkbox"/> <input type="checkbox"/> <input type="checkbox"/>	MS0750-0703F- <input type="checkbox"/> <input type="checkbox"/> <input type="checkbox"/> MS0750-0703FA- <input type="checkbox"/> <input type="checkbox"/> <input type="checkbox"/>	HT0750-0703F- <input type="checkbox"/> <input type="checkbox"/> <input type="checkbox"/> HT0750-0703FA- <input type="checkbox"/> <input type="checkbox"/> <input type="checkbox"/>
ES	HS	MS	HT
ESDR030-100 ESDR621-100 ESDR518-100 ESDR415-100 ESDR312-100 ESDR209-100 ESDR207-150	HDR617-100 HDR617-100 HDR415-100 HDR415-100 HDR-LR312-100 HDR-LR312-100 HDR206-150	MSDR724-100 MSDR724-100 MSDR518-100 MSDR518-100 MSDR-LR312-100 MSDR-LR312-100 MSDR207-150	HTDR827-100 HTDR827-100 HTDR621-100 HTDR621-100 HTDR-LR312-100 HTDR-LR312-100 HTDR-LR209-150
ES0750-0704F- <input type="checkbox"/> <input type="checkbox"/> <input type="checkbox"/> ES0750-0704FA- <input type="checkbox"/> <input type="checkbox"/> <input type="checkbox"/>	HS0750-0704F- <input type="checkbox"/> <input type="checkbox"/> <input type="checkbox"/> HS0750-0704FA- <input type="checkbox"/> <input type="checkbox"/> <input type="checkbox"/>	MS0750-0704F- <input type="checkbox"/> <input type="checkbox"/> <input type="checkbox"/> MS0750-0704FA- <input type="checkbox"/> <input type="checkbox"/> <input type="checkbox"/>	HT0750-0704F- <input type="checkbox"/> <input type="checkbox"/> <input type="checkbox"/> HT0750-0704FA- <input type="checkbox"/> <input type="checkbox"/> <input type="checkbox"/>
ES	HS	MS	HT
ESDR045-75 ESDR-LR312-75 ESDR-LR312-75 ESDR-LR207-75 ESDR310-100 ESDR310-100 ESDR207-100 ESDR207-150	HDR621-75 HDR621-75 HDR518-75 HDR518-75 HDR415-100 HDR415-100 HDR415-100 HDR206-150	MSDR415-75 MSDR415-75 MSDR312-75 MSDR312-75 MSDR-LR210-100 MSDR-LR210-100 MSDR-LR210-100 MSDR-LR209-150	HTDR-LR415-75 HTDR-LR415-75 HTDR-LR312-75 HTDR-LR312-75 HTDR-LR209-100 HTDR-LR209-100 HTDR-LR209-100 HTDR-LR106-150
ES0750-0801F- <input type="checkbox"/> <input type="checkbox"/> <input type="checkbox"/> ES0750-0801FA- <input type="checkbox"/> <input type="checkbox"/> <input type="checkbox"/>	HS0750-0801F- <input type="checkbox"/> <input type="checkbox"/> <input type="checkbox"/> HS0750-0801FA- <input type="checkbox"/> <input type="checkbox"/> <input type="checkbox"/>	MS0750-0801F- <input type="checkbox"/> <input type="checkbox"/> <input type="checkbox"/> MS0750-0801FA- <input type="checkbox"/> <input type="checkbox"/> <input type="checkbox"/>	HT0750-0801F- <input type="checkbox"/> <input type="checkbox"/> <input type="checkbox"/> HT0750-0801FA- <input type="checkbox"/> <input type="checkbox"/> <input type="checkbox"/>

MODEL 900 SHALLOW DEPTH CABINET COMBINATIONS (22.5" DEEP X 39.375" HEIGHT)

■ Select: Base ■ Select: Lock □ Select: Color

See page 6 for details.

	Cabinet Width	NS-16.85" Wide	CL-22.20" Wide	ST-28.23" Wide
 <p>0900-0501</p>	Drawer Capacities	165 lbs. (75kg)	440 lbs. (200kg)	440 lbs. (200kg)
	Drawers Usable Ht. (Points)	NS	CL	ST
	5"	NSDR105-150	CLDR206-150	SDR209-150
	5"	NSDR105-150	CLDR206-150	SDR106-150
	5"	NSDR104-150	CLDR206-150	SDR106-150
	7"	NSDR102-200	CLDR104-200	SDR104-200
	9"	NSDR102-250	CLDR104-250	SDR104-250
Cabinets				
Without interiors	NS0900-0501N- <input type="checkbox"/> <input type="checkbox"/> <input type="checkbox"/>	CL0900-0501F- <input type="checkbox"/> <input type="checkbox"/> <input type="checkbox"/>	ST0900-0501F- <input type="checkbox"/> <input type="checkbox"/> <input type="checkbox"/>	
With Interiors	NS0900-0501NA- <input type="checkbox"/> <input type="checkbox"/> <input type="checkbox"/>	CL0900-0501FA- <input type="checkbox"/> <input type="checkbox"/> <input type="checkbox"/>	ST0900-0501FA- <input type="checkbox"/> <input type="checkbox"/> <input type="checkbox"/>	
 <p>0900-0503</p>	Drawers Usable Ht. (Points)	NS	CL	ST
	3"	NSDR209-100	CLDR209-100	SDR316-100
	5"	NSDR206-150	CLDR206-150	SDR209-150
	7"	NSDR105-200	CLDR104-200	SDR206-200
	7"	NSDR104-200	CLDR104-200	SDR104-200
	7"	NSDR102-250	CLDR104-250	SDR104-250
	Cabinets			
Without interiors	NS0900-0503N- <input type="checkbox"/> <input type="checkbox"/> <input type="checkbox"/>	CL0900-0503F- <input type="checkbox"/> <input type="checkbox"/> <input type="checkbox"/>	ST0900-0503F- <input type="checkbox"/> <input type="checkbox"/> <input type="checkbox"/>	
With Interiors	NS0900-0503NA- <input type="checkbox"/> <input type="checkbox"/> <input type="checkbox"/>	CL0900-0503FA- <input type="checkbox"/> <input type="checkbox"/> <input type="checkbox"/>	ST0900-0503FA- <input type="checkbox"/> <input type="checkbox"/> <input type="checkbox"/>	
 <p>0900-0605</p>	Drawers Usable Ht. (Points)	NS	CL	ST
	5"	NSDR105-150	CLDR206-150	SDR308-150
	5"	NSDR105-150	CLDR206-150	SDR308-150
	5"	NSDR206-150	CLDR206-150	SDR206-150
	5"	NSDR206-150	CLDR104-150	SDR206-150
	5"	NSDR209-150	CLDR104-150	SDR106-150
	5"	NSDR209-150	CLDR104-150	SDR104-150
Cabinets				
Without interiors	NS0900-0605N- <input type="checkbox"/> <input type="checkbox"/> <input type="checkbox"/>	CL0900-0605F- <input type="checkbox"/> <input type="checkbox"/> <input type="checkbox"/>	ST0900-0605F- <input type="checkbox"/> <input type="checkbox"/> <input type="checkbox"/>	
With Interiors	NS0900-0605NA- <input type="checkbox"/> <input type="checkbox"/> <input type="checkbox"/>	CL0900-0605FA- <input type="checkbox"/> <input type="checkbox"/> <input type="checkbox"/>	ST0900-0605FA- <input type="checkbox"/> <input type="checkbox"/> <input type="checkbox"/>	
 <p>0900-0702</p>	Drawers Usable Ht. (Points)	NS	CL	ST
	3"	NSDR106-100	CLDR209-100	SDR316-100
	3"	NSDR106-100	CLDR209-100	SDR316-100
	3"	NSDR104-100	CLDR209-100	SDR209-100
	3"	NSDR104-100	CLDR209-100	SDR209-100
	5"	NSDR206-150	CLDR206-150	SDR206-150
	5"	NSDR105-150	CLDR206-150	SDR206-150
7"	NSDR209-200	CLDR104-200	SDR104-200	
Cabinets				
Without interiors	NS0900-0702N- <input type="checkbox"/> <input type="checkbox"/> <input type="checkbox"/>	CL0900-0702F- <input type="checkbox"/> <input type="checkbox"/> <input type="checkbox"/>	ST0900-0702F- <input type="checkbox"/> <input type="checkbox"/> <input type="checkbox"/>	
With Interiors	NS0900-0702NA- <input type="checkbox"/> <input type="checkbox"/> <input type="checkbox"/>	CL0900-0702FA- <input type="checkbox"/> <input type="checkbox"/> <input type="checkbox"/>	ST0900-0702FA- <input type="checkbox"/> <input type="checkbox"/> <input type="checkbox"/>	

See pages 32-39 for drawer layout detail.

ES-34.25" Wide	HS-40.28" Wide	MS-46.97" Wide	HT-56.34" Wide
440 lbs. (200kg)	440 lbs. (200kg)	440 lbs. (200kg)	440 lbs. (200kg)
ES	HS	MS	HT
ESDR312-150 ESDR312-150 ESDR312-150 ESDR209-200 ESMDL	HDR312-150 HDR206-150 HDR206-150 HDR206-200 HSMDL	MSDR415-150 MSDR312-150 MSDR312-150 MSDR312-200 MSMDL	HTDR-LR312-150 HTDR-LR209-150 HTDR-LR209-150 HTDR-LR209-200 HTDR203-250
ES0900-0501F- <input type="checkbox"/> <input type="checkbox"/> <input type="checkbox"/> ES0900-0501FA- <input type="checkbox"/> <input type="checkbox"/> <input type="checkbox"/>	HS0900-0501F- <input type="checkbox"/> <input type="checkbox"/> <input type="checkbox"/> HS0900-0501FA- <input type="checkbox"/> <input type="checkbox"/> <input type="checkbox"/>	MS0900-0501F- <input type="checkbox"/> <input type="checkbox"/> <input type="checkbox"/> MS0900-0501FA- <input type="checkbox"/> <input type="checkbox"/> <input type="checkbox"/>	HT0900-0501F- <input type="checkbox"/> <input type="checkbox"/> <input type="checkbox"/> HT0900-0501FA- <input type="checkbox"/> <input type="checkbox"/> <input type="checkbox"/>
ES	HS	MS	HT
ESDR312-100 ESDR312-150 ESDR209-200 ESDR209-200 ESDR207-250	HDR415-100 HDR312-150 HDR312-200 HDR206-200 HDR206-250	MSDR518-100 MSDR415-150 MSDR415-200 MSDR312-200 MSDR312-250	HTDR518-100 HTDR415-150 HTDR415-200 HTDR-LR312-200 HTDR-LR312-250
ES0900-0503F- <input type="checkbox"/> <input type="checkbox"/> <input type="checkbox"/> ES0900-0503FA- <input type="checkbox"/> <input type="checkbox"/> <input type="checkbox"/>	HS0900-0503F- <input type="checkbox"/> <input type="checkbox"/> <input type="checkbox"/> HS0900-0503FA- <input type="checkbox"/> <input type="checkbox"/> <input type="checkbox"/>	MS0900-0503F- <input type="checkbox"/> <input type="checkbox"/> <input type="checkbox"/> MS0900-0503FA- <input type="checkbox"/> <input type="checkbox"/> <input type="checkbox"/>	HT0900-0503F- <input type="checkbox"/> <input type="checkbox"/> <input type="checkbox"/> HT0900-0503FA- <input type="checkbox"/> <input type="checkbox"/> <input type="checkbox"/>
ES	HS	MS	HT
ESDR415-150 ESDR415-150 ESDR312-150 ESDR312-150 ESDR209-150 ESDR207-150	HDR518-150 HDR518-150 HDR312-150 HDR312-150 HDR206-150 HDR206-150	MSDR621-150 MSDR621-150 MSDR415-150 MSDR415-150 MSDR312-150 MSDR312-150	HTDR621-150 HTDR621-150 HTDR415-150 HTDR415-150 HTDR-LR312-150 HTDR-LR312-150
ES0900-0605F- <input type="checkbox"/> <input type="checkbox"/> <input type="checkbox"/> ES0900-0605FA- <input type="checkbox"/> <input type="checkbox"/> <input type="checkbox"/>	HS0900-0605F- <input type="checkbox"/> <input type="checkbox"/> <input type="checkbox"/> HS0900-0605FA- <input type="checkbox"/> <input type="checkbox"/> <input type="checkbox"/>	MS0900-0605F- <input type="checkbox"/> <input type="checkbox"/> <input type="checkbox"/> MS0900-0605FA- <input type="checkbox"/> <input type="checkbox"/> <input type="checkbox"/>	HT0900-0605F- <input type="checkbox"/> <input type="checkbox"/> <input type="checkbox"/> HT0900-0605FA- <input type="checkbox"/> <input type="checkbox"/> <input type="checkbox"/>
ES	HS	MS	HT
ESDR518-100 ESDR518-100 ESDR415-100 ESDR415-100 ESDR312-150 ESDR312-150 ESDR209-200	HDR518-100 HDR518-100 HDR415-100 HDR415-100 HDR312-150 HDR312-150 HDR206-200	MSDR621-100 MSDR621-100 MSDR518-100 MSDR518-100 MSDR415-150 MSDR415-150 MSDR312-200	HTDR724-100 HTDR724-100 HTDR621-100 HTDR621-100 HTDR518-150 HTDR518-150 HTDR410-200
ES0900-0702F- <input type="checkbox"/> <input type="checkbox"/> <input type="checkbox"/> ES0900-0702FA- <input type="checkbox"/> <input type="checkbox"/> <input type="checkbox"/>	HS0900-0702F- <input type="checkbox"/> <input type="checkbox"/> <input type="checkbox"/> HS0900-0702FA- <input type="checkbox"/> <input type="checkbox"/> <input type="checkbox"/>	MS0900-0702F- <input type="checkbox"/> <input type="checkbox"/> <input type="checkbox"/> MS0900-0702FA- <input type="checkbox"/> <input type="checkbox"/> <input type="checkbox"/>	HT0900-0702F- <input type="checkbox"/> <input type="checkbox"/> <input type="checkbox"/> HT0900-0702FA- <input type="checkbox"/> <input type="checkbox"/> <input type="checkbox"/>

Model 900 Cabinet Combinations continued on next page.

MODEL 900 SHALLOW DEPTH CABINET COMBINATIONS (22.5" DEEP X 39.375" HEIGHT)

■ Select: Base ■ Select: Lock □ Select: Color

See page 6 for details.

		Cabinet Width	NS-16.85" Wide	CL-22.20" Wide	ST-28.23" Wide
 <p>0900-0703</p>	Drawer Capacities		165 lbs. (75kg)	440 lbs. (200kg)	440 lbs. (200kg)
	Drawers Usable Ht. (Points)		NS	CL	ST
	2"	2.17" (75)	NSDR012-75	CLDR009-75	SDR316-75
	2"	2.17" (75)	NSDR014-75	CLDR009-75	SDR316-75
	3"	3.15" (100)	NSDR209-100	CLDR316-100	SDR209-100
	5"	3.15" (100)	NSDR105-100	CLDR316-100	SDR209-100
	7"	5.12" (150)	NSDR104-150	CLDR209-150	SDR209-150
	7"	7.09" (200)	NSDR104-200	CLDR104-200	SDR104-200
	7"	7.09" (200)	NSDR104-200	CLDR104-200	SDR104-200
	Cabinets				
Without interiors		NS0900-0703N-■□	CL0900-0703F-■□	ST0900-0703F-■□	
With Interiors		NS0900-0703NA-■□	CL0900-0703FA-■□	ST0900-0703FA-■□	
 <p>0900-0901</p>	Drawers Usable Ht. (Points)		NS	CL	ST
	2"	2.17" (75)	NSDR020-75	CLDR018-75	SDR420-75
	2"	2.17" (75)	NSDR008-75	CLDR009-75	SDR420-75
	2"	2.17" (75)	NSDR006-75	CLDR420-75	SDR316-75
	2"	2.17" (75)	NSDR006-75	CLDR415-75	SDR316-75
	3"	3.15" (100)	NSDR206-100	CLDR312-100	SDR316-100
	3"	3.15" (100)	NSDR105-100	CLDR312-100	SDR209-100
	3"	3.15" (100)	NSDR105-100	CLDR312-100	SDR206-100
	5"	5.12" (150)	NSDR104-150	CLDR104-150	SDR206-150
	5"	5.12" (150)	NSDR104-150	CLDR104-150	SDR104-150
Cabinets					
Without interiors		NS0900-0901N-■□	CL0900-0901F-■□	ST0900-0901F-■□	
With Interiors		NS0900-0901NA-■□	CL0900-0901FA-■□	ST0900-0901FA-■□	
 <p>0900-0904</p>	Drawers Usable Ht. (Points)		NS	CL	ST
	3"	3.15" (100)	NSDR012-100	CLDR415-100	SDR518-100
	3"	3.15" (100)	NSDR012-100	CLDR415-100	SDR518-100
	3"	3.15" (100)	NSDR006-100	CLDR415-100	SDR518-100
	3"	3.15" (100)	NSDR006-100	CLDR312-100	SDR420-100
	3"	3.15" (100)	NSDR206-100	CLDR312-100	SDR420-100
	3"	3.15" (100)	NSDR206-100	CLDR312-100	SDR420-100
	3"	3.15" (100)	NSDR106-100	CLDR206-100	SDR312-100
	3"	3.15" (100)	NSDR106-100	CLDR206-100	SDR312-100
	3"	3.15" (100)	NSDR105-100	CLDR206-100	SDR312-100
Cabinets					
Without interiors		NS0900-0904N-■□	CL0900-0904F-■□	ST0900-0904F-■□	
With Interiors		NS0900-0904NA-■□	CL0900-0904FA-■□	ST0900-0904FA-■□	
 <p>0900-1001</p>	Drawers Usable Ht. (Points)		NS	CL	ST
	2"	2.17" (75)	NSDR020-75	CLDR018-75	SDR024-75
	2"	2.17" (75)	NSDR008-75	CLDR018-75	SDR024-75
	2"	2.17" (75)	NSDR209-75	CLDR018-75	SDR518-75
	2"	2.17" (75)	NSDR209-75	CLDR312-75	SDR518-75
	2"	2.17" (75)	NSDR206-75	CLDR312-75	SDR420-75
	2"	2.17" (75)	NSDR206-75	CLDR312-75	SDR420-75
	3"	3.15" (100)	NSDR106-100	CLDR209-100	SDR312-100
	4"	3.15" (100)	NSDR106-100	CLDR209-100	SDR312-100
	4"	4.13" (125)	NSDR104-100	CLDR209-100	SDR206-100
4"	4.13" (125)	NSDR104-100	CLDR209-100	SDR206-100	
Cabinets					
Without interiors		NS0900-1001N-■□	CL0900-1001F-■□	ST0900-1001F-■□	
With Interiors		NS0900-1001NA-■□	CL0900-1001FA-■□	ST0900-1001FA-■□	





See pages 32-39 for drawer layout detail.

ES-34.25" Wide	HS-40.28" Wide	MS-46.97" Wide	HT-56.34" Wide
440 lbs. (200kg)	440 lbs. (200kg)	440 lbs. (200kg)	440 lbs. (200kg)
ES	HS	MS	HT
ESDR621-75 ESDR518-75 ESDR415-100 ESDR415-100 ESDR312-150 ESDR209-200 ESDR209-200	HDR040 HDR024-75 HDR617-100 HDR-LR312-100 HDR312-150 HDR206-200 HDR206-200	MSDR030-75 MSDR724-75 MSDR621-100 MSDR-LR312-100 MSDR312-150 MSDR207-200 MSDR207-200	HTDR724-75 HTDR724-75 HTDR621-100 HTDR621-100 HTDR-LR312-150 HTDR-LR312-200 HTDR-LR312-200
ES0900-0703F- <input type="checkbox"/> <input type="checkbox"/> <input type="checkbox"/> ES0900-0703FA- <input type="checkbox"/> <input type="checkbox"/> <input type="checkbox"/>	HS0900-0703F- <input type="checkbox"/> <input type="checkbox"/> <input type="checkbox"/> HS0900-0703FA- <input type="checkbox"/> <input type="checkbox"/> <input type="checkbox"/>	MS0900-0703F- <input type="checkbox"/> <input type="checkbox"/> <input type="checkbox"/> MS0900-0703FA- <input type="checkbox"/> <input type="checkbox"/> <input type="checkbox"/>	HT0900-0703F- <input type="checkbox"/> <input type="checkbox"/> <input type="checkbox"/> HT0900-0703FA- <input type="checkbox"/> <input type="checkbox"/> <input type="checkbox"/>
ES	HS	MS	HT
ESDR415-75 ESDR415-75 ESDR312-75 ESDR312-75 ESDR312-100 ESDR209-100 ESDR209-100 ESDR-LR209-150 ESDR-LR209-150	HDR518-75 HDR518-75 HDR415-75 HDR415-75 HDR415-100 HDR312-100 HDR312-100 HDR206-150 HDR206-150	MSDR621-75 MSDR621-75 MSDR518-75 MSDR518-75 MSDR518-100 MSDR415-100 MSDR415-100 MSDR-LR209-150 MSDR-LR209-150	HTDR621-75 HTDR621-75 HTDR518-75 HTDR518-75 HTDR518-100 HTDR410-100 HTDR410-100 HTDR-LR209-150 HTDR-LR209-150
ES0900-0901F- <input type="checkbox"/> <input type="checkbox"/> <input type="checkbox"/> ES0900-0901FA- <input type="checkbox"/> <input type="checkbox"/> <input type="checkbox"/>	HS0900-0901F- <input type="checkbox"/> <input type="checkbox"/> <input type="checkbox"/> HS0900-0901FA- <input type="checkbox"/> <input type="checkbox"/> <input type="checkbox"/>	MS0900-0901F- <input type="checkbox"/> <input type="checkbox"/> <input type="checkbox"/> MS0900-0901FA- <input type="checkbox"/> <input type="checkbox"/> <input type="checkbox"/>	HT0900-0901F- <input type="checkbox"/> <input type="checkbox"/> <input type="checkbox"/> HT0900-0901FA- <input type="checkbox"/> <input type="checkbox"/> <input type="checkbox"/>
ES	HS	MS	HT
ESDR518-100 ESDR518-100 ESDR518-100 ESDR415-100 ESDR415-100 ESDR415-100 ESDR312-100 ESDR312-100 ESDR312-100	HDR617-100 HDR617-100 HDR617-100 HDR415-100 HDR415-100 HDR415-100 HDR-LR207-100 HDR-LR207-100 HDR-LR207-100	MSDR724-100 MSDR724-100 MSDR724-100 MSDR518-100 MSDR518-100 MSDR518-100 MSDR-LR209-100 MSDR-LR209-100 MSDR-LR209-100	HTDR724-100 HTDR724-100 HTDR724-100 HTDR518-100 HTDR518-100 HTDR518-100 HTDR-LR209-100 HTDR-LR209-100 HTDR-LR209-100
ES0900-0904F- <input type="checkbox"/> <input type="checkbox"/> <input type="checkbox"/> ES0900-0904FA- <input type="checkbox"/> <input type="checkbox"/> <input type="checkbox"/>	HS0900-0904F- <input type="checkbox"/> <input type="checkbox"/> <input type="checkbox"/> HS0900-0904FA- <input type="checkbox"/> <input type="checkbox"/> <input type="checkbox"/>	MS0900-0904F- <input type="checkbox"/> <input type="checkbox"/> <input type="checkbox"/> MS0900-0904FA- <input type="checkbox"/> <input type="checkbox"/> <input type="checkbox"/>	HT0900-0904F- <input type="checkbox"/> <input type="checkbox"/> <input type="checkbox"/> HT0900-0904FA- <input type="checkbox"/> <input type="checkbox"/> <input type="checkbox"/>
ES	HS	MS	HT
ESDR030-75 ESDR030-75 ESDR518-75 ESDR518-75 ESDR415-75 ESDR415-75 ESDR312-100 ESDR312-100 ESDR209-100 ESDR209-100	HDR036-75 HDR036-75 HDR518-75 HDR518-75 HDR415-75 HDR415-75 HDR-LR312-100 HDR-LR312-100 HDR206-100 HDR206-100	MSDR030-75 MSDR030-75 MSDR624-75 MSDR624-75 MSDR518-75 MSDR518-75 MSDR-LR312-100 MSDR-LR312-100 MSDR207-100 MSDR207-100	HTDR724-75 HTDR724-75 HTDR621-75 HTDR621-75 HTDR-LR415-75 HTDR-LR415-75 HTDR-LR312-100 HTDR-LR312-100 HTDR-LR209-100 HTDR-LR209-100
ES0900-1001F- <input type="checkbox"/> <input type="checkbox"/> <input type="checkbox"/> ES0900-1001FA- <input type="checkbox"/> <input type="checkbox"/> <input type="checkbox"/>	HS0900-1001F- <input type="checkbox"/> <input type="checkbox"/> <input type="checkbox"/> HS0900-1001FA- <input type="checkbox"/> <input type="checkbox"/> <input type="checkbox"/>	MS0900-1001F- <input type="checkbox"/> <input type="checkbox"/> <input type="checkbox"/> MS0900-1001FA- <input type="checkbox"/> <input type="checkbox"/> <input type="checkbox"/>	HT0900-1001F- <input type="checkbox"/> <input type="checkbox"/> <input type="checkbox"/> HT0900-1001FA- <input type="checkbox"/> <input type="checkbox"/> <input type="checkbox"/>

MODEL 1200 SHALLOW DEPTH CABINET COMBINATIONS (22.5" DEEP X 51.18" HEIGHT)

■ Select: Base ■ Select: Lock □ Select: Color

See page 6 for details.

	Cabinet Width	NS-16.85" Wide	CL-22.20" Wide	ST-28.23" Wide
 <p>1200-0601</p>	Drawer Capacities	165 lbs. (75kg)	440 lbs. (200kg)	440 lbs. (200kg)
	Drawers			
	Usable Ht. (Points)	NS	CL	ST
	3.15" (100)	NSDR105-100	CLDR104-100	SDR206-100
	7.09" (200)	NSDR104-200	CLDR104-200	SDR206-200
	7.09" (200)	NSDR104-200	CLDR104-200	SDR206-200
	7.09" (200)	NSDR106-200	CLDR104-200	SDR104-200
	9.06" (250)	NSDR102-250	CLDR104-250	SDR104-250
	9.06" (250)	NSDR102-250	CLDR104-250	SDR104-250
	Cabinets			
Without interiors	NS1200-0601N- <input type="checkbox"/> <input type="checkbox"/> <input type="checkbox"/>	CL1200-0601F- <input type="checkbox"/> <input type="checkbox"/> <input type="checkbox"/>	ST1200-0601F- <input type="checkbox"/> <input type="checkbox"/> <input type="checkbox"/>	
With Interiors	NS1200-0601NA- <input type="checkbox"/> <input type="checkbox"/> <input type="checkbox"/>	CL1200-0601FA- <input type="checkbox"/> <input type="checkbox"/> <input type="checkbox"/>	ST1200-0601FA- <input type="checkbox"/> <input type="checkbox"/> <input type="checkbox"/>	
 <p>1200-0801</p>	Drawers			
	Usable Ht. (Points)	NS	CL	ST
	3.15" (100)	NSDR206-100	CLDR209-100	SDR316-100
	3.15" (100)	NSDR206-100	CLDR209-100	SDR316-100
	3.15" (100)	NSDR206-100	CLDR206-100	SDR316-100
	5.12" (150)	NSDR106-150	CLDR206-150	SDR209-150
	5.12" (150)	NSDR106-150	CLDR206-150	SDR209-150
	7.09" (200)	NSDR-LR203-200	CLDR104-200	SDR104-200
	7.09" (200)	NSDR-LR203-200	CLDR104-200	SDR104-200
	7.09" (200)	NSDR102-200	CLDR104-200	SDR104-200
Cabinets				
Without interiors	NS1200-0801N- <input type="checkbox"/> <input type="checkbox"/> <input type="checkbox"/>	CL1200-0801F- <input type="checkbox"/> <input type="checkbox"/> <input type="checkbox"/>	ST1200-0801F- <input type="checkbox"/> <input type="checkbox"/> <input type="checkbox"/>	
With Interiors	NS1200-0801NA- <input type="checkbox"/> <input type="checkbox"/> <input type="checkbox"/>	CL1200-0801FA- <input type="checkbox"/> <input type="checkbox"/> <input type="checkbox"/>	ST1200-0801FA- <input type="checkbox"/> <input type="checkbox"/> <input type="checkbox"/>	
 <p>1200-1001</p>	Drawers			
	Usable Ht. (Points)	NS	CL	ST
	2.17" (75)	NSDR206-75	CLDR312-75	SDR316-75
	2.17" (75)	NSDR206-75	CLDR312-75	SDR316-75
	2.17" (75)	NSDR206-75	CLDR312-75	SDR316-75
	2.17" (75)	NSDR206-75	CLDR312-75	SDR316-75
	3.15" (100)	NSDR206-100	CLDR316-100	SDR316-100
	3.15" (100)	NSDR206-100	CLDR316-100	SDR316-100
	5.12" (150)	NSDR106-150	CLDR316-150	SDR209-150
	5.12" (150)	NSDR106-150	CLDR316-150	SDR209-150
7.09" (200)	NSDR104-200	CLDR206-200	SDR104-200	
7.09" (200)	NSDR104-200	CLDR206-200	SDR104-200	
Cabinets				
Without interiors	NS1200-1001N- <input type="checkbox"/> <input type="checkbox"/> <input type="checkbox"/>	CL1200-1001F- <input type="checkbox"/> <input type="checkbox"/> <input type="checkbox"/>	ST1200-1001F- <input type="checkbox"/> <input type="checkbox"/> <input type="checkbox"/>	
With Interiors	NS1200-1001NA- <input type="checkbox"/> <input type="checkbox"/> <input type="checkbox"/>	CL1200-1001FA- <input type="checkbox"/> <input type="checkbox"/> <input type="checkbox"/>	ST1200-1001FA- <input type="checkbox"/> <input type="checkbox"/> <input type="checkbox"/>	
 <p>1200-1301</p>	Drawers			
	Usable Ht. (Points)	NS	CL	ST
	2.17" (75)	NSDR104-75	CLDR206-75	SDR518-75
	2.17" (75)	NSDR104-75	CLDR206-75	SDR518-75
	2.17" (75)	NSDR104-75	CLDR206-75	SDR518-75
	2.17" (75)	NSDR105-75	CLDR209-75	SDR518-75
	2.17" (75)	NSDR105-75	CLDR209-75	SDR518-75
	2.17" (75)	NSDR105-75	CLDR209-75	SDR518-75
	3.15" (100)	NSDR104-100	CLDR312-100	SDR316-100
	3.15" (100)	NSDR104-100	CLDR312-100	SDR316-100
3.15" (100)	NSDR104-100	CLDR312-100	SDR316-100	
3.15" (100)	NSDR105-100	CLDR104-100	SDR316-100	
3.15" (100)	NSDR105-100	CLDR104-100	SDR316-100	
3.15" (100)	NSDR105-100	CLDR104-100	SDR316-100	
5.12" (150)	NSDR104-150	CLDR104-150	SDR209-150	
Cabinets				
Without interiors	NS1200-1301N- <input type="checkbox"/> <input type="checkbox"/> <input type="checkbox"/>	CL1200-1301F- <input type="checkbox"/> <input type="checkbox"/> <input type="checkbox"/>	ST1200-1301F- <input type="checkbox"/> <input type="checkbox"/> <input type="checkbox"/>	
With Interiors	NS1200-1301NA- <input type="checkbox"/> <input type="checkbox"/> <input type="checkbox"/>	CL1200-1301FA- <input type="checkbox"/> <input type="checkbox"/> <input type="checkbox"/>	ST1200-1301FA- <input type="checkbox"/> <input type="checkbox"/> <input type="checkbox"/>	

See pages 32-39 for drawer layout detail.

ES-34.25" Wide	HS-40.28" Wide	MS-46.97" Wide	HT-56.34" Wide
440 lbs. (200kg)	440 lbs. (200kg)	440 lbs. (200kg)	440 lbs. (200kg)
ES	HS	MS	HT
ESDR-LR312-100 ESDR-LR312-200 ESDR-LR209-200 ESDR-LR209-200 ESDR-LR207-250 ESDR-LR207-250	HDR-LR312-100 HDR-LR312-200 HDR-LR209-200 HDR-LR209-200 HDR-LR207-250 HDR-LR207-250	MSDR-LR312-100 MSDR-LR312-200 MSDR-LR210-200 MSDR-LR210-200 MSDR-LR209-250 MSDR-LR209-250	HTDR-LR312-100 HTDR-LR312-200 HTDR-LR209-200 HTDR-LR209-200 HTDR-LR209-250 HTDR-LR209-250
ES1200-0601F- <input type="checkbox"/> <input type="checkbox"/> <input type="checkbox"/> ES1200-0601FA- <input type="checkbox"/> <input type="checkbox"/> <input type="checkbox"/>	HS1200-0601F- <input type="checkbox"/> <input type="checkbox"/> <input type="checkbox"/> HS1200-0601FA- <input type="checkbox"/> <input type="checkbox"/> <input type="checkbox"/>	MS1200-0601F- <input type="checkbox"/> <input type="checkbox"/> <input type="checkbox"/> MS1200-0601FA- <input type="checkbox"/> <input type="checkbox"/> <input type="checkbox"/>	HT1200-0601F- <input type="checkbox"/> <input type="checkbox"/> <input type="checkbox"/> HT1200-0601FA- <input type="checkbox"/> <input type="checkbox"/> <input type="checkbox"/>
ES	HS	MS	HT
ESDR-LR312-100 ESDR-LR312-100 ESDR-LR312-100 ESDR-LR312-150 ESDR-LR209-150 ESDR-LR209-200 ESDR-LR209-200 ESDR207-200	HDR-LR312-100 HDR-LR312-100 HDR-LR312-100 HDR-LR312-150 HDR-LR209-150 HDR-LR209-200 HDR-LR209-200 HDR-LR207-200	MSDR-LR312-100 MSDR-LR312-100 MSDR-LR312-100 MSDR-LR312-150 MSDR-LR210-150 MSDR-LR210-200 MSDR-LR210-200 MSDR-LR209-200	HTDR-LR312-100 HTDR-LR312-100 HTDR-LR312-100 HTDR-LR312-150 HTDR-LR209-150 HTDR-LR209-200 HTDR-LR209-200 HTDR-LR106-200
ES1200-0801F- <input type="checkbox"/> <input type="checkbox"/> <input type="checkbox"/> ES1200-0801FA- <input type="checkbox"/> <input type="checkbox"/> <input type="checkbox"/>	HS1200-0801F- <input type="checkbox"/> <input type="checkbox"/> <input type="checkbox"/> HS1200-0801FA- <input type="checkbox"/> <input type="checkbox"/> <input type="checkbox"/>	MS1200-0801F- <input type="checkbox"/> <input type="checkbox"/> <input type="checkbox"/> MS1200-0801FA- <input type="checkbox"/> <input type="checkbox"/> <input type="checkbox"/>	HT1200-0801F- <input type="checkbox"/> <input type="checkbox"/> <input type="checkbox"/> HT1200-0801FA- <input type="checkbox"/> <input type="checkbox"/> <input type="checkbox"/>
ES	HS	MS	HT
ESDR621-75 ESDR621-75 ESDR621-75 ESDR518-75 ESDR518-100 ESDR518-100 ESDR415-150 ESDR415-150 ESDR312-200 ESDR312-200	HDR621-75 HDR621-75 HDR621-75 HDR518-75 HDR518-100 HDR518-100 HDR415-150 HDR415-150 HDR312-200 HDR312-200	MSDR724-75 MSDR724-75 MSDR724-75 MSDR621-75 MSDR621-100 MSDR621-100 MSDR518-150 MSDR518-150 MSDR415-200 MSDR415-200	HTDR827-75 HTDR827-75 HTDR827-75 HTDR724-75 HTDR724-100 HTDR724-100 HTDR621-150 HTDR621-150 HTDR518-200 HTDR518-200
ES1200-1001F- <input type="checkbox"/> <input type="checkbox"/> <input type="checkbox"/> ES1200-1001FA- <input type="checkbox"/> <input type="checkbox"/> <input type="checkbox"/>	HS1200-1001F- <input type="checkbox"/> <input type="checkbox"/> <input type="checkbox"/> HS1200-1001FA- <input type="checkbox"/> <input type="checkbox"/> <input type="checkbox"/>	MS1200-1001F- <input type="checkbox"/> <input type="checkbox"/> <input type="checkbox"/> MS1200-1001FA- <input type="checkbox"/> <input type="checkbox"/> <input type="checkbox"/>	HT1200-1001F- <input type="checkbox"/> <input type="checkbox"/> <input type="checkbox"/> HT1200-1001FA- <input type="checkbox"/> <input type="checkbox"/> <input type="checkbox"/>
ES	HS	MS	HT
ESDR518-75 ESDR518-75 ESDR518-75 ESDR518-75 ESDR518-75 ESDR312-75 ESDR312-100 ESDR312-100 ESDR312-100 ESDR312-100 ESDR312-100 ESDR312-100 ESDR312-100 ESDR312-100 ESDR209-150	HDR621-75 HDR621-75 HDR621-75 HDR621-75 HDR621-75 HDR415-75 HDR415-100 HDR415-100 HDR415-100 HDR415-100 HDR415-100 HDR415-100 HDR415-100 HDR312-150	MSDR621-75 MSDR621-75 MSDR621-75 MSDR621-75 MSDR621-75 MSDR415-75 MSDR415-100 MSDR415-100 MSDR415-100 MSDR415-100 MSDR415-100 MSDR415-100 MSDR415-100 MSDR312-150	HTDR724-75 HTDR724-75 HTDR724-75 HTDR724-75 HTDR724-75 HTDR518-75 HTDR518-100 HTDR518-100 HTDR518-100 HTDR518-100 HTDR518-100 HTDR518-100 HTDR518-100 HTDR415-150
ES1200-1301F- <input type="checkbox"/> <input type="checkbox"/> <input type="checkbox"/> ES1200-1301FA- <input type="checkbox"/> <input type="checkbox"/> <input type="checkbox"/>	HS1200-1301F- <input type="checkbox"/> <input type="checkbox"/> <input type="checkbox"/> HS1200-1301FA- <input type="checkbox"/> <input type="checkbox"/> <input type="checkbox"/>	MS1200-1301F- <input type="checkbox"/> <input type="checkbox"/> <input type="checkbox"/> MS1200-1301FA- <input type="checkbox"/> <input type="checkbox"/> <input type="checkbox"/>	HT1200-1301F- <input type="checkbox"/> <input type="checkbox"/> <input type="checkbox"/> HT1200-1301FA- <input type="checkbox"/> <input type="checkbox"/> <input type="checkbox"/>

MODEL 1350 SHALLOW DEPTH CABINET COMBINATIONS (22.5" DEEP X 57.125" HEIGHT)

■ Select: Base ■ Select: Lock □ Select: Color

See page 6 for details.

See pages 32-39 for drawer layout detail.

	Cabinet Width	NS-16.85" Wide	CL-22.20" Wide	ST-28.23" Wide
 1350-0608	Drawer Capacities	165 lbs. (75kg)	440 lbs. (200kg)	440 lbs. (200kg)
	Drawers Usable Ht. (Points)	NS	CL	ST
	5.12" (150)	NSDR209-150	CLDR206-150	SDR308-150
	7.09" (200)	NSDR206-200	CLDR206-200	SDR209-200
	9.06" (250)	NSDR104-250	CLDR104-250	SDR106-250
	9.06" (250)	NSDR105-250	CLDR104-250	SDR106-250
	9.06" (250)	NSDR105-250	CLDR104-250	SDR104-250
Cabinets				
Without interiors	NS1350-0608N- <input type="checkbox"/> <input type="checkbox"/> <input type="checkbox"/>	CL1350-0608F- <input type="checkbox"/> <input type="checkbox"/> <input type="checkbox"/>	ST1350-0608F- <input type="checkbox"/> <input type="checkbox"/> <input type="checkbox"/>	
With Interiors	NS1350-0608NA- <input type="checkbox"/> <input type="checkbox"/> <input type="checkbox"/>	CL1350-0608FA- <input type="checkbox"/> <input type="checkbox"/> <input type="checkbox"/>	ST1350-0608FA- <input type="checkbox"/> <input type="checkbox"/> <input type="checkbox"/>	
 1350-0702	Drawers Usable Ht. (Points)	NS	CL	ST
	5.12" (150)	NSDR105-150	CLDR104-150	SDR316-150
	5.12" (150)	NSDR105-150	CLDR104-150	SDR209-150
	5.12" (150)	NSDR206-150	CLDR104-150	SDR209-150
	7.09" (200)	NSDR209-200	CLDR206-200	SDR206-200
	7.09" (200)	NSDR105-200	CLDR209-200	SDR104-200
	9.06" (250)	NSDR104-250	CLDR104-250	SDR104-250
9.06" (250)	NSDR104-250	CLDR104-250	SDR104-250	
Cabinets				
Without interiors	NS1350-0702N- <input type="checkbox"/> <input type="checkbox"/> <input type="checkbox"/>	CL1350-0702F- <input type="checkbox"/> <input type="checkbox"/> <input type="checkbox"/>	ST1350-0702F- <input type="checkbox"/> <input type="checkbox"/> <input type="checkbox"/>	
With Interiors	NS1350-0702NA- <input type="checkbox"/> <input type="checkbox"/> <input type="checkbox"/>	CL1350-0702FA- <input type="checkbox"/> <input type="checkbox"/> <input type="checkbox"/>	ST1350-0702FA- <input type="checkbox"/> <input type="checkbox"/> <input type="checkbox"/>	
 1350-0801	Drawers Usable Ht. (Points)	NS	CL	ST
	5.12" (150)	NSDR105-150	CLDR206-150	SDR316-150
	5.12" (150)	NSDR105-150	CLDR206-150	SDR316-150
	5.12" (150)	NSDR206-150	CLDR206-150	SDR209-150
	5.12" (150)	NSDR206-150	CLDR206-150	SDR209-150
	5.12" (150)	NSDR104-150	CLDR206-150	SDR209-150
	7.09" (200)	NSDR104-200	CLDR209-200	SDR209-200
7.09" (200)	NSDR104-200	CLDR209-200	SDR209-200	
7.09" (200)	NSDR105-200	CLDR209-200	SDR104-200	
Cabinets				
Without interiors	NS1350-0801N- <input type="checkbox"/> <input type="checkbox"/> <input type="checkbox"/>	CL1350-0801F- <input type="checkbox"/> <input type="checkbox"/> <input type="checkbox"/>	ST1350-0801F- <input type="checkbox"/> <input type="checkbox"/> <input type="checkbox"/>	
With Interiors	NS1350-0801NA- <input type="checkbox"/> <input type="checkbox"/> <input type="checkbox"/>	CL1350-0801FA- <input type="checkbox"/> <input type="checkbox"/> <input type="checkbox"/>	ST1350-0801FA- <input type="checkbox"/> <input type="checkbox"/> <input type="checkbox"/>	
 1350-0803	Drawers Usable Ht. (Points)	NS	CL	ST
	5.12" (150)	NSDR104-150	CLDR104-150	SDR308-150
	5.12" (150)	NSDR104-150	CLDR104-150	SDR308-150
	5.12" (150)	NSDR105-150	CLDR312-150	SDR308-150
	5.12" (150)	NSDR105-150	CLDR312-150	SDR308-150
	5.12" (150)	NSDR206-150	CLDR316-150	SDR308-150
	5.12" (150)	NSDR206-150	CLDR316-150	SDR308-150
7.09" (200)	NSDR104-200	CLDR206-200	SDR206-200	
9.06" (250)	NSDR102-250	CLDR104-250	SDR206-250	
Cabinets				
Without interiors	NS1350-0803N- <input type="checkbox"/> <input type="checkbox"/> <input type="checkbox"/>	CL1350-0803F- <input type="checkbox"/> <input type="checkbox"/> <input type="checkbox"/>	ST1350-0803F- <input type="checkbox"/> <input type="checkbox"/> <input type="checkbox"/>	
With Interiors	NS1350-0803NA- <input type="checkbox"/> <input type="checkbox"/> <input type="checkbox"/>	CL1350-0803FA- <input type="checkbox"/> <input type="checkbox"/> <input type="checkbox"/>	ST1350-0803FA- <input type="checkbox"/> <input type="checkbox"/> <input type="checkbox"/>	

**Model 1350 Cabinet Combinations
continued on the next page**

ES—34.25" Wide	HS—40.28" Wide	MS—46.97" Wide	HT—56.34" Wide
440 lbs. (200kg)	440 lbs. (200kg)	440 lbs. (200kg)	440 lbs. (200kg)
ES	HS	MS	HT
ESDR415-150 ESDR312-200 ESDR209-250 ESDR209-250 ESDR207-250 ESDR104-250	HDR518-150 HDR415-200 HDR312-250 HDR312-250 HDR312-250 HDR206-250	MSDR518-150 MSDR415-200 MSDR312-250 MSDR312-250 MSDR312-250 MSDR207-250	HTDR621-150 HTDR518-200 HTDR415-250 HTDR415-250 HTDR410-250 HTDR-LR209-250
ES1350-0608F- <input type="checkbox"/> <input type="checkbox"/> <input type="checkbox"/> ES1350-0608FA- <input type="checkbox"/> <input type="checkbox"/> <input type="checkbox"/>	HS1350-0608F- <input type="checkbox"/> <input type="checkbox"/> <input type="checkbox"/> HS1350-0608FA- <input type="checkbox"/> <input type="checkbox"/> <input type="checkbox"/>	MS1350-0608F- <input type="checkbox"/> <input type="checkbox"/> <input type="checkbox"/> MS1350-0608FA- <input type="checkbox"/> <input type="checkbox"/> <input type="checkbox"/>	HT1350-0608F- <input type="checkbox"/> <input type="checkbox"/> <input type="checkbox"/> HT1350-0608FA- <input type="checkbox"/> <input type="checkbox"/> <input type="checkbox"/>
ES	HS	MS	HT
ESDR312-150 ESDR312-150 ESDR312-150 ESDR312-200 ESDR207-200 ESDR207-250 ESDR207-250	HDR312-150 HDR312-150 HDR312-150 HDR312-200 HDR206-200 HDR206-250 HDR206-250	MSDR312-150 MSDR312-150 MSDR312-150 MSDR312-200 MSDR-LR209-200 MSDR-LR209-250 MSDR-LR209-250	HTDR-LR312-150 HTDR-LR312-150 HTDR-LR312-150 HTDR-LR312-200 HTDR-LR209-200 HTDR-LR209-250 HTDR-LR209-250
ES1350-0702F- <input type="checkbox"/> <input type="checkbox"/> <input type="checkbox"/> ES1350-0702FA- <input type="checkbox"/> <input type="checkbox"/> <input type="checkbox"/>	HS1350-0702F- <input type="checkbox"/> <input type="checkbox"/> <input type="checkbox"/> HS1350-0702FA- <input type="checkbox"/> <input type="checkbox"/> <input type="checkbox"/>	MS1350-0702F- <input type="checkbox"/> <input type="checkbox"/> <input type="checkbox"/> MS1350-0702FA- <input type="checkbox"/> <input type="checkbox"/> <input type="checkbox"/>	HT1350-0702F- <input type="checkbox"/> <input type="checkbox"/> <input type="checkbox"/> HT1350-0702FA- <input type="checkbox"/> <input type="checkbox"/> <input type="checkbox"/>
ES	HS	MS	HT
ESDR312-150 ESDR312-150 ESDR312-150 ESDR209-150 ESDR209-150 ESDR209-200 ESDR-LR209-200 ESDR-LR209-200	HDR312-150 HDR312-150 HDR312-150 HDR312-150 HDR312-150 HDR206-200 HDR206-200 HDR206-200	MSDR415-150 MSDR415-150 MSDR415-150 MSDR415-150 MSDR415-150 MSDR-LR209-200 MSDR-LR209-200 MSDR-LR209-200	HTDR-LR106-150 HTDR-LR106-150 HTDR-LR312-150 HTDR-LR312-150 HTDR-LR312-150 HTDR-LR209-200 HTDR-LR209-200 HTDR-LR209-200
ES1350-0801F- <input type="checkbox"/> <input type="checkbox"/> <input type="checkbox"/> ES1350-0801FA- <input type="checkbox"/> <input type="checkbox"/> <input type="checkbox"/>	HS1350-0801F- <input type="checkbox"/> <input type="checkbox"/> <input type="checkbox"/> HS1350-0801FA- <input type="checkbox"/> <input type="checkbox"/> <input type="checkbox"/>	MS1350-0801F- <input type="checkbox"/> <input type="checkbox"/> <input type="checkbox"/> MS1350-0801FA- <input type="checkbox"/> <input type="checkbox"/> <input type="checkbox"/>	HT1350-0801F- <input type="checkbox"/> <input type="checkbox"/> <input type="checkbox"/> HT1350-0801FA- <input type="checkbox"/> <input type="checkbox"/> <input type="checkbox"/>
ES	HS	MS	HT
ESDR415-150 ESDR415-150 ESDR415-150 ESDR415-150 ESDR415-150 ESDR415-150 ESDR209-200 ESDR209-250	HDR415-150 HDR415-150 HDR415-150 HDR415-150 HDR415-150 HDR415-150 HDR312-200 HDR312-250	MSDR518-150 MSDR518-150 MSDR518-150 MSDR518-150 MSDR518-150 MSDR518-150 MSDR415-200 MSDR415-250	HTDR-LR312-150 HTDR-LR312-150 HTDR-LR312-150 HTDR-LR209-150 HTDR-LR209-150 HTDR-LR106-150 HTDR-LR106-200 HTDR203-250
ES1350-0803F- <input type="checkbox"/> <input type="checkbox"/> <input type="checkbox"/> ES1350-0803FA- <input type="checkbox"/> <input type="checkbox"/> <input type="checkbox"/>	HS1350-0803F- <input type="checkbox"/> <input type="checkbox"/> <input type="checkbox"/> HS1350-0803FA- <input type="checkbox"/> <input type="checkbox"/> <input type="checkbox"/>	MS1350-0803F- <input type="checkbox"/> <input type="checkbox"/> <input type="checkbox"/> MS1350-0803FA- <input type="checkbox"/> <input type="checkbox"/> <input type="checkbox"/>	HT1350-0803F- <input type="checkbox"/> <input type="checkbox"/> <input type="checkbox"/> HT1350-0803FA- <input type="checkbox"/> <input type="checkbox"/> <input type="checkbox"/>

MODEL 1350 SHALLOW DEPTH CABINET COMBINATIONS (22.5" DEEP X 57.125" HEIGHT)

■ Select: Base ■ Select: Lock □ Select: Color

See page 6 for details.

See pages 32-39 for drawer layout detail.

	Cabinet Width	NS-16.85" Wide	CL-22.20" Wide	ST-28.23" Wide
 1350-0902	Drawer Capacities	165 lbs. (75kg)	440 lbs. (200kg)	440 lbs. (200kg)
	Drawers	NS	CL	ST
	Usable Ht. (Points)			
	3.15" (100)	NSDR209-100	CLDR415-100	SDR316-100
	3.15" (100)	NSDR206-100	CLDR415-100	SDR316-100
	3.15" (100)	NSDR105-100	CLDR415-100	SDR316-100
	5.12" (150)	NSDR209-150	CLDR312-150	SDR209-150
	5.12" (150)	NSDR206-150	CLDR312-150	SDR209-150
	5.12" (150)	NSDR105-150	CLDR312-150	SDR206-150
	7.09" (200)	NSDR209-200	CLDR206-200	SDR206-200
7.09" (200)	NSDR206-200	CLDR206-200	SDR104-200	
7.09" (200)	NSDR105-200	CLDR206-200	SDR104-200	
Cabinets				
Without interiors	NS1350-0902N- <input type="checkbox"/> <input type="checkbox"/> <input type="checkbox"/>	CL1350-0902F- <input type="checkbox"/> <input type="checkbox"/> <input type="checkbox"/>	ST1350-0902F- <input type="checkbox"/> <input type="checkbox"/> <input type="checkbox"/>	
With Interiors	NS1350-0902NA- <input type="checkbox"/> <input type="checkbox"/> <input type="checkbox"/>	CL1350-0902FA- <input type="checkbox"/> <input type="checkbox"/> <input type="checkbox"/>	ST1350-0902FA- <input type="checkbox"/> <input type="checkbox"/> <input type="checkbox"/>	
 1350-0903	Drawers	NS	CL	ST
	Usable Ht. (Points)			
	5.12" (150)	NSDR206-150	CLDR312-150	SDR312-150
	5.12" (150)	NSDR206-150	CLDR312-150	SDR312-150
	5.12" (150)	NSDR206-150	CLDR312-150	SDR312-150
	5.12" (150)	NSDR105-150	CLDR209-150	SDR312-150
	5.12" (150)	NSDR105-150	CLDR209-150	SDR209-150
	5.12" (150)	NSDR105-150	CLDR206-150	SDR209-150
	5.12" (150)	NSDR104-150	CLDR206-150	SDR209-150
	5.12" (150)	NSDR104-150	CLDR104-150	SDR209-150
5.12" (150)	NSDR104-150	CLDR104-150	SDR209-150	
Cabinets				
Without interiors	NS1350-0903N- <input type="checkbox"/> <input type="checkbox"/> <input type="checkbox"/>	CL1350-0903F- <input type="checkbox"/> <input type="checkbox"/> <input type="checkbox"/>	ST1350-0903F- <input type="checkbox"/> <input type="checkbox"/> <input type="checkbox"/>	
With Interiors	NS1350-0903NA- <input type="checkbox"/> <input type="checkbox"/> <input type="checkbox"/>	CL1350-0903FA- <input type="checkbox"/> <input type="checkbox"/> <input type="checkbox"/>	ST1350-0903FA- <input type="checkbox"/> <input type="checkbox"/> <input type="checkbox"/>	
 1350-1002	Drawers	NS	CL	ST
	Usable Ht. (Points)			
	2.17" (75)	NSDR102-75	CLDR104-75	SDR420-75
	2.17" (75)	NSDR102-75	CLDR104-75	SDR420-75
	3.15" (100)	NSDR104-100	CLDR104-100	SDR316-100
	3.15" (100)	NSDR104-100	CLDR104-100	SDR316-100
	3.15" (100)	NSDR104-100	CLDR104-100	SDR316-100
	5.12" (150)	NSDR105-150	CLDR206-150	SDR209-150
	5.12" (150)	NSDR105-150	CLDR206-150	SDR209-150
	7.09" (200)	NSDR102-200	CLDR206-200	SDR209-200
9.06" (250)	NSDR102-250	CLDR104-250	SDR104-250	
Cabinets				
Without interiors	NS1350-1002N- <input type="checkbox"/> <input type="checkbox"/> <input type="checkbox"/>	CL1350-1002F- <input type="checkbox"/> <input type="checkbox"/> <input type="checkbox"/>	ST1350-1002F- <input type="checkbox"/> <input type="checkbox"/> <input type="checkbox"/>	
With Interiors	NS1350-1002NA- <input type="checkbox"/> <input type="checkbox"/> <input type="checkbox"/>	CL1350-1002FA- <input type="checkbox"/> <input type="checkbox"/> <input type="checkbox"/>	ST1350-1002FA- <input type="checkbox"/> <input type="checkbox"/> <input type="checkbox"/>	
 1350-1103	Drawers	NS	CL	ST
	Usable Ht. (Points)			
	2.17" (75)	NSDR104-75	CLDR206-75	SDR316-75
	2.17" (75)	NSDR104-75	CLDR206-75	SDR316-75
	2.17" (75)	NSDR104-75	CLDR206-75	SDR316-75
	2.17" (75)	NSDR104-75	CLDR206-75	SDR316-75
	4.13" (125)	NSDR105-100	CLDR415-100	SDR312-100
	4.13" (125)	NSDR105-100	CLDR415-100	SDR312-100
	4.13" (125)	NSDR105-100	CLDR420-100	SDR312-100
	4.13" (125)	NSDR105-100	CLDR420-100	SDR312-100
5.12" (150)	NSDR106-150	CLDR209-150	SDR312-150	
5.12" (150)	NSDR106-150	CLDR209-150	SDR312-150	
9.06" (250)	NSDR106-250	CLDR104-250	SDR104-250	
Cabinets				
Without interiors	NS1350-1103N- <input type="checkbox"/> <input type="checkbox"/> <input type="checkbox"/>	CL1350-1103F- <input type="checkbox"/> <input type="checkbox"/> <input type="checkbox"/>	ST1350-1103F- <input type="checkbox"/> <input type="checkbox"/> <input type="checkbox"/>	
With Interiors	NS1350-1103NA- <input type="checkbox"/> <input type="checkbox"/> <input type="checkbox"/>	CL1350-1103FA- <input type="checkbox"/> <input type="checkbox"/> <input type="checkbox"/>	ST1350-1103FA- <input type="checkbox"/> <input type="checkbox"/> <input type="checkbox"/>	

**Model 1350 Cabinet Combinations
continued on the next page**

ES-34.25" Wide	HS-40.28" Wide	MS-46.97" Wide	HT-56.34" Wide
440 lbs. (200kg)	440 lbs. (200kg)	440 lbs. (200kg)	440 lbs. (200kg)
ES	HS	MS	HT
ESDR415-100 ESDR415-100 ESDR415-100 ESDR312-150 ESDR312-150 ESDR312-150 ESDR312-200 ESDR209-200 ESDR209-200	HDR415-100 HDR415-100 HDR415-100 HDR312-150 HDR312-150 HDR312-150 HDR312-200 HDR206-200 HDR206-200	MSDR518-100 MSDR518-100 MSDR518-100 MSDR415-150 MSDR415-150 MSDR415-150 MSDR415-200 MSDR312-200 MSDR312-200	HTDR-LR415-100 HTDR-LR312-100 HTDR-LR312-100 HTDR-LR312-150 HTDR-LR209-150 HTDR-LR209-150 HTDR-LR209-200 HTDR-LR106-200 HTDR-LR106-200
ES1350-0902F- <input type="checkbox"/> <input type="checkbox"/> <input type="checkbox"/> ES1350-0902FA- <input type="checkbox"/> <input type="checkbox"/> <input type="checkbox"/>	HS1350-0902F- <input type="checkbox"/> <input type="checkbox"/> <input type="checkbox"/> HS1350-0902FA- <input type="checkbox"/> <input type="checkbox"/> <input type="checkbox"/>	MS1350-0902F- <input type="checkbox"/> <input type="checkbox"/> <input type="checkbox"/> MS1350-0902FA- <input type="checkbox"/> <input type="checkbox"/> <input type="checkbox"/>	HT1350-0902F- <input type="checkbox"/> <input type="checkbox"/> <input type="checkbox"/> HT1350-0902FA- <input type="checkbox"/> <input type="checkbox"/> <input type="checkbox"/>
ES	HS	MS	HT
ESDR415-150 ESDR415-150 ESDR415-150 ESDR415-150 ESDR312-150 ESDR312-150 ESDR312-150 ESDR312-150 ESDR312-150 ESDR312-150	HDR518-150 HDR518-150 HDR518-150 HDR518-150 HDR312-150 HDR312-150 HDR312-150 HDR312-150 HDR312-150 HDR312-150	MSDR621-150 MSDR621-150 MSDR621-150 MSDR621-150 MSDR415-150 MSDR415-150 MSDR415-150 MSDR415-150 MSDR415-150 MSDR415-150	HTDR724-150 HTDR724-150 HTDR724-150 HTDR621-150 HTDR621-150 HTDR621-150 HTDR518-150 HTDR518-150 HTDR518-150 HTDR518-150
ES1350-0903F- <input type="checkbox"/> <input type="checkbox"/> <input type="checkbox"/> ES1350-0903FA- <input type="checkbox"/> <input type="checkbox"/> <input type="checkbox"/>	HS1350-0903F- <input type="checkbox"/> <input type="checkbox"/> <input type="checkbox"/> HS1350-0903FA- <input type="checkbox"/> <input type="checkbox"/> <input type="checkbox"/>	MS1350-0903F- <input type="checkbox"/> <input type="checkbox"/> <input type="checkbox"/> MS1350-0903FA- <input type="checkbox"/> <input type="checkbox"/> <input type="checkbox"/>	HT1350-0903F- <input type="checkbox"/> <input type="checkbox"/> <input type="checkbox"/> HT1350-0903FA- <input type="checkbox"/> <input type="checkbox"/> <input type="checkbox"/>
ES	HS	MS	HT
ESDR621-75 ESDR621-75 ESDR518-100 ESDR518-100 ESDR518-100 ESDR415-150 ESDR415-150 ESDR415-150 ESDR312-200 ESDR207-250	HDR621-75 HDR621-75 HDR518-100 HDR518-100 HDR518-100 HDR415-150 HDR415-150 HDR415-150 HDR312-200 HDR206-250	MSDR724-75 MSDR724-75 MSDR621-100 MSDR621-100 MSDR621-100 MSDR518-150 MSDR518-150 MSDR518-150 MSDR415-200 MSDR312-250	HTDR827-75 HTDR827-75 HTDR724-100 HTDR724-100 HTDR724-100 HTDR621-150 HTDR621-150 HTDR621-150 HTDR518-200 HTDR518-250
ES1350-1002F- <input type="checkbox"/> <input type="checkbox"/> <input type="checkbox"/> ES1350-1002FA- <input type="checkbox"/> <input type="checkbox"/> <input type="checkbox"/>	HS1350-1002F- <input type="checkbox"/> <input type="checkbox"/> <input type="checkbox"/> HS1350-1002FA- <input type="checkbox"/> <input type="checkbox"/> <input type="checkbox"/>	MS1350-1002F- <input type="checkbox"/> <input type="checkbox"/> <input type="checkbox"/> MS1350-1002FA- <input type="checkbox"/> <input type="checkbox"/> <input type="checkbox"/>	HT1350-1002F- <input type="checkbox"/> <input type="checkbox"/> <input type="checkbox"/> HT1350-1002FA- <input type="checkbox"/> <input type="checkbox"/> <input type="checkbox"/>
ES	HS	MS	HT
ESDR415-75 ESDR415-75 ESDR415-75 ESDR415-75 ESDR312-100 ESDR312-100 ESDR312-100 ESDR312-100 ESDR312-100 ESDR312-150 ESDR312-150 ESDR207-250	HDR415-75 HDR415-75 HDR415-75 HDR415-75 HDR312-100 HDR312-100 HDR312-100 HDR312-100 HDR312-100 HDR-LR209-150 HDR-LR209-150 HDR206-250	MSDR518-75 MSDR518-75 MSDR518-75 MSDR518-75 MSDR415-100 MSDR415-100 MSDR415-100 MSDR415-100 MSDR415-100 MSDR-LR210-150 MSDR-LR210-150 MSDR207-250	HTDR621-75 HTDR621-75 HTDR621-75 HTDR621-75 HTDR518-100 HTDR518-100 HTDR518-100 HTDR518-100 HTDR518-100 HTDR-LR209-150 HTDR-LR209-150 HTDR-LR209-250
ES1350-1103F- <input type="checkbox"/> <input type="checkbox"/> <input type="checkbox"/> ES1350-1103FA- <input type="checkbox"/> <input type="checkbox"/> <input type="checkbox"/>	HS1350-1103F- <input type="checkbox"/> <input type="checkbox"/> <input type="checkbox"/> HS1350-1103FA- <input type="checkbox"/> <input type="checkbox"/> <input type="checkbox"/>	MS1350-1103F- <input type="checkbox"/> <input type="checkbox"/> <input type="checkbox"/> MS1350-1103FA- <input type="checkbox"/> <input type="checkbox"/> <input type="checkbox"/>	HT1350-1103F- <input type="checkbox"/> <input type="checkbox"/> <input type="checkbox"/> HT1350-1103FA- <input type="checkbox"/> <input type="checkbox"/> <input type="checkbox"/>

MODEL 1350 SHALLOW DEPTH CABINET COMBINATIONS (22.5" DEEP X 57.125" HEIGHT)

■ Select: Base ■ Select: Lock □ Select: Color

See page 6 for details.

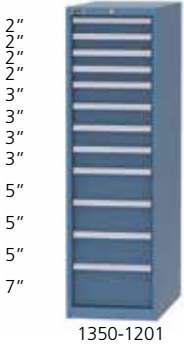

Cabinet Width	NS-16.85" Wide	CL-22.20" Wide	ST-28.23" Wide
Drawer Capacities	165 lbs. (75kg)	440 lbs. (200kg)	440 lbs. (200kg)
Drawers Usable Ht. (Points)	NS	CL	ST
2.17" (75)	NSDR105-75	CLDR209-75	SDR420-75
2.17" (75)	NSDR105-75	CLDR209-75	SDR420-75
2.17" (75)	NSDR105-75	CLDR206-75	SDR316-75
3.15" (100)	NSDR105-75	CLDR206-75	SDR316-75
3.15" (100)	NSDR105-100	CLDR316-100	SDR316-100
3.15" (100)	NSDR105-100	CLDR316-100	SDR316-100
3.15" (100)	NSDR206-100	CLDR312-100	SDR209-100
3.15" (100)	NSDR206-100	CLDR312-100	SDR209-100
5.12" (150)	NSDR104-150	CLDR209-150	SDR206-150
5.12" (150)	NSDR104-150	CLDR206-150	SDR206-150
5.12" (150)	NSDR104-150	CLDR206-150	SDR104-150
7.09" (200)	NSDR104-200	CLDR104-200	SDR104-200
Cabinets			
Without interiors	NS1350-1201N-■□	CL1350-1201F-■□	ST1350-1201F-■□
With Interiors	NS1350-1201NA-■□	CL1350-1201FA-■□	ST1350-1201FA-■□

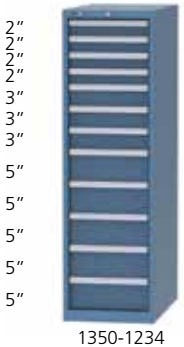

Drawers	NS	CL	ST
Usable Ht. (Points)			
2.17" (75)	NSDR-LR203-75	CLDR206-75	SDR518-75
2.17" (75)	NSDR-LR203-75	CLDR206-75	SDR518-75
2.17" (75)	NSDR-LR203-75	CLDR206-75	SDR420-75
2.17" (75)	NSDR-LR203-75	CLDR206-75	SDR420-75
3.15" (100)	NSDR102-100	CLDR312-100	SDR518-100
3.15" (100)	NSDR102-100	CLDR312-100	SDR518-100
3.15" (100)	NSDR102-100	CLDR312-100	SDR420-100
3.15" (100)	NSDR102-100	CLDR312-100	SDR420-100
5.12" (150)	NSDR104-150	CLDR206-150	SDR308-150
5.12" (150)	NSDR104-150	CLDR206-150	SDR308-150
5.12" (150)	NSDR105-150	CLDR206-150	SDR308-150
5.12" (150)	NSDR105-150	CLDR206-150	SDR206-150
5.12" (150)	NSDR105-150	CLDR206-150	SDR206-150
Cabinets			
Without interiors	NS1350-1234N-■□	CL1350-1234F-■□	ST1350-1234F-■□
With Interiors	NS1350-1234NA-■□	CL1350-1234FA-■□	ST1350-1234FA-■□

See pages 32-39 for drawer layout detail.



CABINETS

ES-34.25" Wide	HS-40.28" Wide	MS-46.97" Wide	HT-56.34" Wide
440 lbs. (200kg)	440 lbs. (200kg)	440 lbs. (200kg)	440 lbs. (200kg)
ES	HS	MS	HT
ESDR518-75 ESDR518-75 ESDR415-75 ESDR415-75 ESDR-LR312-100 ESDR-LR312-100 ESDR-LR209-100 ESDR-LR209-100 ESDR-LR209-150 ESDR-LR209-150 ESDR-LR207-150 ESDR-LR207-200	HDR415-75 HDR415-75 HDR312-75 HDR312-75 HDR312-100 HDR312-100 HDR-LR209-100 HDR-LR209-100 HDR206-150 HDR206-150 HDR-LR106-150 HDR-LR106-200	MSDR518-75 MSDR518-75 MSDR415-75 MSDR415-75 MSDR415-100 MSDR415-100 MSDR312-100 MSDR312-100 MSDR-LR209-150 MSDR-LR209-150 MSDR207-150 MSDR207-200	HTDR-LR415-75 HTDR-LR415-75 HTDR-LR415-75 HTDR-LR415-75 HTDR-LR312-100 HTDR-LR312-100 HTDR-LR312-100 HTDR-LR312-100 HTDR-LR209-150 HTDR-LR209-150 HTDR-LR106-150 HTDR-LR106-200
ES1350-1201F- <input type="checkbox"/> <input type="checkbox"/> <input type="checkbox"/> ES1350-1201FA- <input type="checkbox"/> <input type="checkbox"/> <input type="checkbox"/>	HS1350-1201F- <input type="checkbox"/> <input type="checkbox"/> <input type="checkbox"/> HS1350-1201FA- <input type="checkbox"/> <input type="checkbox"/> <input type="checkbox"/>	MS1350-1201F- <input type="checkbox"/> <input type="checkbox"/> <input type="checkbox"/> MS1350-1201FA- <input type="checkbox"/> <input type="checkbox"/> <input type="checkbox"/>	HT1350-1201F- <input type="checkbox"/> <input type="checkbox"/> <input type="checkbox"/> HT1350-1201FA- <input type="checkbox"/> <input type="checkbox"/> <input type="checkbox"/>
ES	HS	MS	HT
ESDR621-75 ESDR621-75 ESDR518-75 ESDR518-75 ESDR621-100 ESDR621-100 ESDR518-100 ESDR415-150 ESDR415-150 ESDR415-150 ESDR312-150 ESDR312-150	HDR621-75 HDR621-75 HDR518-75 HDR518-75 HDR621-100 HDR621-100 HDR518-100 HDR415-150 HDR415-150 HDR415-150 HDR206-150 HDR206-150	MSDR724-75 MSDR724-75 MSDR621-75 MSDR621-75 MSDR724-100 MSDR724-100 MSDR621-100 MSDR518-150 MSDR518-150 MSDR518-150 MSDR312-150 MSDR312-150	HTDR827-75 HTDR827-75 HTDR724-75 HTDR724-75 HTDR621-100 HTDR621-100 HTDR518-100 HTDR518-150 HTDR518-150 HTDR415-150 HTDR415-150 HTDR415-150
ES1350-1234F- <input type="checkbox"/> <input type="checkbox"/> <input type="checkbox"/> ES1350-1234FA- <input type="checkbox"/> <input type="checkbox"/> <input type="checkbox"/>	HS1350-1234F- <input type="checkbox"/> <input type="checkbox"/> <input type="checkbox"/> HS1350-1234FA- <input type="checkbox"/> <input type="checkbox"/> <input type="checkbox"/>	MS1350-1234F- <input type="checkbox"/> <input type="checkbox"/> <input type="checkbox"/> MS1350-1234FA- <input type="checkbox"/> <input type="checkbox"/> <input type="checkbox"/>	HT1350-1234F- <input type="checkbox"/> <input type="checkbox"/> <input type="checkbox"/> HT1350-1234FA- <input type="checkbox"/> <input type="checkbox"/> <input type="checkbox"/>

Model 1350 Cabinet Combinations continued on the next page

MODEL 1350 SHALLOW DEPTH CABINET COMBINATIONS (22.5" DEEP X 57.125" HEIGHT)

■ Select: Base ■ Select: Lock □ Select: Color

See page 6 for details.

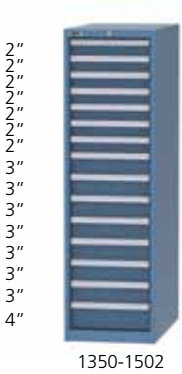

Cabinet Width	NS-16.85" Wide	CL-22.20" Wide	ST-28.23" Wide
Drawer Capacities	165 lbs. (75kg)	440 lbs. (200kg)	440 lbs. (200kg)
Drawers Usable Ht. (Points)	NS	CL	ST
2.17" (75)	NSDR102-75	CLDR312-75	SDR312-75
2.17" (75)	NSDR102-75	CLDR312-75	SDR312-75
2.17" (75)	NSDR102-75	CLDR312-75	SDR312-75
2.17" (75)	NSDR102-75	CLDR415-75	SDR312-75
2.17" (75)	NSDR-LR203-75	CLDR415-75	SDR312-75
2.17" (75)	NSDR-LR203-75	CLDR415-75	SDR312-75
2.17" (75)	NSDR-LR203-75	CLDR415-75	SDR312-75
3.15" (100)	NSDR006-100	CLDR420-100	SDR312-100
3.15" (100)	NSDR006-100	CLDR420-100	SDR312-100
3.15" (100)	NSDR106-100	CLDR420-100	SDR312-100
3.15" (100)	NSDR106-100	CLDR420-100	SDR312-100
3.15" (100)	NSDR209-100	CLDR209-100	SDR312-100
3.15" (100)	NSDR206-100	CLDR209-100	SDR312-100
3.15" (100)	NSDR105-100	CLDR209-100	SDR312-100
4.13" (125)	NSDR105-100	CLDR209-100	SDR312-100
Cabinets			
Without interiors	NS1350-1502N-■ ■ □	CL1350-1502F-■ ■ □	ST1350-1502F-■ ■ □
With Interiors	NS1350-1502NA-■ ■ □	CL1350-1502FA-■ ■ □	ST1350-1502FA-■ ■ □

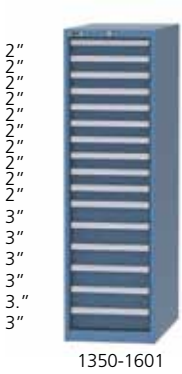

Drawers	NS	CL	ST
Usable Ht. (Points)			
2.17" (75)	NSDR104-75	CLDR206-75	SDR420-75
2.17" (75)	NSDR104-75	CLDR206-75	SDR420-75
2.17" (75)	NSDR104-75	CLDR206-75	SDR420-75
2.17" (75)	NSDR104-75	CLDR206-75	SDR420-75
2.17" (75)	NSDR104-75	CLDR420-75	SDR420-75
2.17" (75)	NSDR105-75	CLDR420-75	SDR316-75
2.17" (75)	NSDR105-75	CLDR420-75	SDR316-75
2.17" (75)	NSDR105-75	CLDR316-75	SDR316-75
2.17" (75)	NSDR105-75	CLDR316-75	SDR316-75
2.17" (75)	NSDR105-75	CLDR316-75	SDR316-75
3.15" (100)	NSDR105-100	CLDR312-100	SDR316-100
3.15" (100)	NSDR105-100	CLDR312-100	SDR316-100
3.15" (100)	NSDR105-100	CLDR209-100	SDR316-100
3.15" (100)	NSDR102-100	CLDR209-100	SDR209-100
3.15" (100)	NSDR102-100	CLDR104-100	SDR209-100
3.15" (100)	NSDR102-100	CLDR104-100	SDR209-100
Cabinets			
Without interiors	NS1350-1601N-■ ■ □	CL1350-1601F-■ ■ □	ST1350-1601F-■ ■ □
With Interiors	NS1350-1601NA-■ ■ □	CL1350-1601FA-■ ■ □	ST1350-1601FA-■ ■ □

See pages 32-39 for drawer layout detail.



CABINETS

ES-34.25" Wide	HS-40.28" Wide	MS-46.97" Wide	HT-56.34" Wide
440 lbs. (200kg)	440 lbs. (200kg)	440 lbs. (200kg)	440 lbs. (200kg)
ES	HS	MS	HT
ESDR-LR312-75 ESDR-LR312-75 ESDR-LR209-75 ESDR-LR209-75 ESDR-LR209-75 ESDR-LR207-75 ESDR-LR207-75 ESDR-LR312-100 ESDR-LR312-100 ESDR-LR312-100 ESDR-LR209-100 ESDR-LR209-100 ESDR-LR209-100 ESDR-LR207-100 ESDR-LR207-100	HDR-LR312-75 HDR-LR312-75 HDR-LR209-75 HDR-LR209-75 HDR-LR209-75 HDR-LR207-75 HDR-LR207-75 HDR-LR312-100 HDR-LR312-100 HDR-LR312-100 HDR-LR209-100 HDR-LR209-100 HDR-LR209-100 HDR-LR207-100 HDR-LR207-100	MSDR-LR312-75 MSDR-LR312-75 MSDR-LR209-75 MSDR-LR209-75 MSDR-LR209-75 MSDR-LR210-75 MSDR-LR210-75 MSDR-LR312-100 MSDR-LR312-100 MSDR-LR312-100 MSDR-LR209-100 MSDR-LR209-100 MSDR-LR209-100 MSDR-LR210-100 MSDR-LR210-100	HTDR-LR415-75 HTDR-LR415-75 HTDR-LR312-75 HTDR-LR312-75 HTDR-LR312-75 HTDR-LR209-75 HTDR-LR209-75 HTDR-LR415-100 HTDR-LR415-100 HTDR-LR312-100 HTDR-LR312-100 HTDR-LR209-100 HTDR-LR209-100 HTDR-LR106-100 HTDR-LR106-100
ES1350-1502F- <input type="checkbox"/> <input type="checkbox"/> <input type="checkbox"/> ES1350-1502FA- <input type="checkbox"/> <input type="checkbox"/> <input type="checkbox"/>	HS1350-1502F- <input type="checkbox"/> <input type="checkbox"/> <input type="checkbox"/> HS1350-1502FA- <input type="checkbox"/> <input type="checkbox"/> <input type="checkbox"/>	MS1350-1502F- <input type="checkbox"/> <input type="checkbox"/> <input type="checkbox"/> MS1350-1502FA- <input type="checkbox"/> <input type="checkbox"/> <input type="checkbox"/>	HT1350-1502F- <input type="checkbox"/> <input type="checkbox"/> <input type="checkbox"/> HT1350-1502FA- <input type="checkbox"/> <input type="checkbox"/> <input type="checkbox"/>
ES	HS	MS	HT
ESDR015-75 ESDR015-75 ESDR045 ESDR621-75 ESDR621-75 ESDR518-75 ESDR518-75 ESDR518-75 ESDR415-75 ESDR415-75 ESDR415-100 ESDR312-100 ESDR312-100 ESDR312-100 ESDR207-100 ESDR207-100	HDR024-75 HDR024-75 HDR-LR312-75 HDR621-75 HDR621-75 HDR518-75 HDR518-75 HDR518-75 HDR415-75 HDR415-75 HDR415-100 HDR312-100 HDR312-100 HDR312-100 HDR-LR207-100 HDR-LR207-100	MSDR030-75 MSDR030-75 MSDR-LR312-75 MSDR621-75 MSDR621-75 MSDR518-75 MSDR518-75 MSDR518-75 MSDR415-75 MSDR415-75 MSDR415-100 MSDR312-100 MSDR312-100 MSDR312-100 MSDR207-100 MSDR207-100	HTDR724-75 HTDR724-75 HTDR621-75 HTDR621-75 HTDR518-75 HTDR518-75 HTDR415-75 HTDR415-75 HTDR-LR415-75 HTDR-LR415-75 HTDR-LR312-100 HTDR-LR312-100 HTDR-LR209-100 HTDR-LR209-100 HTDR-LR106-100 HTDR-LR106-100
ES1350-1601F- <input type="checkbox"/> <input type="checkbox"/> <input type="checkbox"/> ES1350-1601FA- <input type="checkbox"/> <input type="checkbox"/> <input type="checkbox"/>	HS1350-1601F- <input type="checkbox"/> <input type="checkbox"/> <input type="checkbox"/> HS1350-1601FA- <input type="checkbox"/> <input type="checkbox"/> <input type="checkbox"/>	MS1350-1601F- <input type="checkbox"/> <input type="checkbox"/> <input type="checkbox"/> MS1350-1601FA- <input type="checkbox"/> <input type="checkbox"/> <input type="checkbox"/>	HT1350-1601F- <input type="checkbox"/> <input type="checkbox"/> <input type="checkbox"/> HT1350-1601FA- <input type="checkbox"/> <input type="checkbox"/> <input type="checkbox"/>

How to order an NS Width Preconfigured Drawer Interior Set

To order the drawer interior sets shown on this page, use the part number in the chart and add the drawer height in place of the green box.

EXAMPLE: to order a NSDR420 drawer interior set for a 100 height (3") drawer, the part ordering number would be **NSDR420-100**.



For drawer heights 75 through 300

PART NO.	COMPTS.	CMPT. WIDTH
NSDR102- 	1	5.24"
	1	6.21"



For drawer heights 75 through 300

PART NO.	COMPTS.	CMPT. WIDTH
NSDR104- 	2	5.54"
	2	6.21"



For drawer heights 75 through 300

PART NO.	COMPTS.	CMPT. WIDTH
NSDR105- 	3	4.20"
	2	7.55"



For drawer heights 75 through 300

PART NO.	COMPTS.	CMPT. WIDTH
NSDR106- 	3	5.54"
	3	6.21"



For drawer heights 75 through 300

PART NO.	COMPTS.	CMPT. WIDTH
NSDR-LR203- 	3	12.23"



For drawer heights 75 through 300

PART NO.	COMPTS.	CMPT. WIDTH
NSDR206- 	4	3.53"
	4	4.20"



For drawer heights 75 through 300

PART NO.	COMPTS.	CMPT. SIZE
NSDR209- 	6	3.53"
	3	4.20"



For drawer heights 75 through 125

PART NO.	COMPTS.	CMPT. WIDTH
NSDR006- 	6	6" x 6"



For drawer heights 75 through 125

PART NO.	COMPTS.	CMPT. WIDTH
NSDR008- 	4	3" x 6"
	4	6" x 6"



For drawer heights 75 through 125

PART NO.	COMPTS.	CMPT. WIDTH
NSDR012- 	3	3" x 6"



For drawer height 75

PART NO.	COMPTS.	CMPT. SIZE
NSDR014-75	8	3" x 3"
	4	3" x 6"
	2	6" x 6"



For drawer height 75

PART NO.	COMPTS.	CMPT. SIZE
NSDR020-75	16	3" x 3"
	4	3" x 6"



For drawer height 75

PART NO.	COMPTS.	CMPT. SIZE
NSDR062	32	2.75"



For drawer height 75

PART NO.	COMPTS.	CMPT. SIZE
NSDR063	48	1.75"

How to order a CL Width

Preconfigured Drawer Interior Set

To order the drawer interior sets shown on this page, use the part number in the chart and add the drawer height in place of the green box.

EXAMPLE: to order a CLDR420 drawer interior set for a 100 height (3") drawer, the part ordering number would be **CLDR420-100**.



For all drawer heights

PART NO.	COMPTS.	CMPT. WIDTH
CLDR104-■	2	7.50"
	2	9.25"



For drawer heights 75 through 250

PART NO.	COMPTS.	CMPT. WIDTH
CLDR206-■	6	5.50"



For drawer heights 75 through 250

PART NO.	COMPTS.	CMPT. WIDTH
CLDR209-■	9	5.50"



For drawer heights 75 through 200

PART NO.	COMPTS.	CMPT. WIDTH
CLDR312-■	3	3.50"
	9	4.125"



For drawer heights 75 through 200

PART NO.	COMPTS.	CMPT. WIDTH
CLDR316-■	4	3.50"
	12	4.125"



For drawer heights 75 through 125

PART NO.	COMPTS.	CMPT. WIDTH
CLDR415-■	9	2.625"
	6	3.50"



For drawer heights 75 through 125

PART NO.	COMPTS.	CMPT. WIDTH
CLDR420-■	12	2.625"
	8	3.50"



For drawer heights 75 through 125

PART NO.	COMPTS.	CMPT. SIZE
CLDR009-■	9	6" x 6"



For drawer heights 75 through 125

PART NO.	COMPTS.	CMPT. SIZE
CLDR012-■	6	6" x 6"
	6	3" x 6"



For drawer heights 75 through 125

PART NO.	COMPTS.	CMPT. SIZE
CLDR018-■	18	3" x 6"

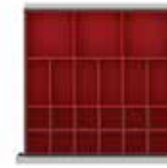

For drawer height 75

PART NO.	COMPTS.	CMPT. SIZE
CLDR021-75	3	6" x 6"
	6	3" x 6"
	12	3" x 3"

How to order an ST Width Preconfigured Drawer Interior Set

To order the drawer interior sets shown on this page, use the part number in the chart and add the drawer height in place of the green box.

EXAMPLE: to order an SDR308 drawer interior set for a 100 height (3") drawer, the part ordering number would be **SDR308-100**.



For all drawer heights		
PART NO.	COMPTS.	CMPT. WIDTH
SDR104- 	4	11.50"



For all drawer heights		
PART NO.	COMPTS.	CMPT. WIDTH
SDR106- 	6	11.50"

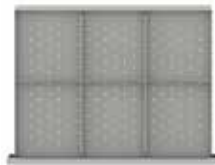

For all drawer heights		
PART NO.	COMPTS.	CMPT. WIDTH
SDR206- 	6	7.50"



For all drawer heights		
PART NO.	COMPTS.	CMPT. WIDTH
SDR209- 	9	7.50"



For all drawer heights		
PART NO.	COMPTS.	CMPT. WIDTH
SDR308- 	8	5.50"



For all drawer heights		
PART NO.	COMPTS.	CMPT. WIDTH
SDR312- 	12	5.50"



For all drawer heights		
PART NO.	COMPTS.	CMPT. WIDTH
SDR316- 	16	5.50"



For drawer heights 75 through 200

PART NO.	COMPTS.	CMPT. WIDTH
SDR420-■	16	4.125"
	4	4.875"



For drawer heights 75 through 200

PART NO.	COMPTS.	CMPT. WIDTH
SDR518-■	18	3.50"



For drawer heights 75 through 200

PART NO.	COMPTS.	CMPT. WIDTH
SDR530-■	30	3.50"



For drawer heights 75 and 100

PART NO.	COMPTS.	CMPT. SIZE
SDR012-■	12	6" x 6"



For drawer heights 75 and 100

PART NO.	COMPTS.	CMPT. SIZE
SDR020-■	4	6" x 6"
	16	3" x 6"



For drawer heights 75 and 100

PART NO.	COMPTS.	CMPT. SIZE
SDR024-■	24	3" x 6"

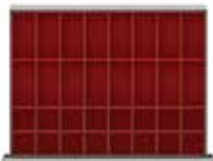

For drawer height 75

PART NO.	COMPTS.	CMPT. SIZE
SDR032-75	16	3" x 6"
	16	3" x 3"



For drawer height 75

PART NO.	COMPTS.	CMPT. WIDTH
SDR160-75	24	2.25"
	36	1.75"

How to order an ES Width Preconfigured Drawer Interior Set

To order the drawer interior sets shown on this page, use the part number in the chart and add the drawer height in place of the green box.

EXAMPLE: to order an ESDR312 drawer interior set for a 100 height (3") drawer, the part ordering number would be **ESDR312-100**.



For all drawer heights		
PART NO.	COMPTS.	CMPT. WIDTH
ESDR-LR207-█	3	3.53"
	2	5.54"
	2	7.55"

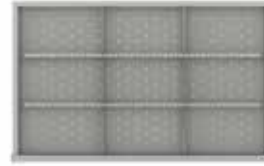

For all drawer heights		
PART NO.	COMPTS.	CMPT. WIDTH
ESDR-LR209-█	9	5.54"

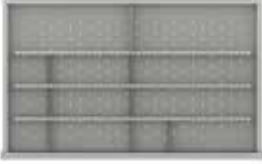

For drawer heights 75 through 300		
PART NO.	COMPTS.	CMPT. WIDTH
ESDR-LR312-█	10	3.53"
	2	5.54"

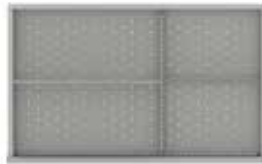

For all drawer heights		
PART NO.	COMPTS.	CMPT. WIDTH
ESDR104-█	2	17.59"
	2	11.56"



For drawer heights 75 through 200		
PART NO.	COMPTS.	CMPT. WIDTH
ESDR207-█	3	7.55"
	2	9.56"
	2	11.56"



For drawer heights 75 through 200		
PART NO.	COMPTS.	CMPT. WIDTH
ESDR209-█	9	9.56"



For drawer heights 75 through 200		
PART NO.	COMPTS.	CMPT. WIDTH
ESDR310-█	3	3.53"
	3	5.54"
	2	7.55"
	2	11.56"



For drawer heights 75 and 100		
PART NO.	COMPTS.	CMPT. SIZE
ESDR312-█	3	5.54"
	9	7.55"



For drawer heights 75 and 100		
PART NO.	COMPTS.	CMPT. SIZE
ESDR415-█	15	5.54"



For drawer height 75		
PART NO.	COMPTS.	CMPT. SIZE
ESDR518-█	9	4.20"
	9	4.87"



For drawer height 75		
PART NO.	COMPTS.	CMPT. WIDTH
ESDR621-█	12	3.53"
	9	4.20"



For drawer heights 75 through 125		
PART NO.	COMPTS.	CMPT. WIDTH
ESDR015-█	15	6" x 6"



For drawer heights 75 through 125		
PART NO.	COMPTS.	CMPT. WIDTH
ESDR024-█	18	3" x 6"
	6	6" x 6"



For drawer heights 75 through 125		
PART NO.	COMPTS.	CMPT. WIDTH
ESDR030-█	30	3" x 6"

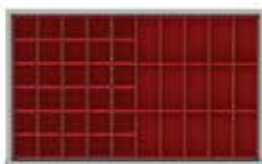

For drawer height 75		
PART NO.	COMPTS.	CMPT. WIDTH
ESDR045-75	30	3" x 3"
	15	3" x 6"

How to order an HS Width Preconfigured Drawer Interior Set

To order the drawer interior sets shown on this page, use the part number in the chart and add the drawer height in place of the green box.

EXAMPLE: to order an HDR312 drawer interior set for a 100 height (3") drawer, the part ordering number would be **HDR312-100**.



For all drawer heights		
PART NO.	COMPTS.	CMPT. WIDTH
HDR-LR106-█	3	7.50"
	3	9.50"



For drawer heights 75 through 200		
PART NO.	COMPTS.	CMPT. WIDTH
HDR617-█	10	3.50"
	5	5.50"
	2	7.50"



For all drawer heights		
PART NO.	COMPTS.	CMPT. WIDTH
HDR-LR209-█	9	5.50"



For drawer heights 75 through 200		
PART NO.	COMPTS.	CMPT. WIDTH
HDR-LR312-█	10	3.50"
	2	5.50"



For all drawer heights		
PART NO.	COMPTS.	CMPT. WIDTH
HDR206-█	6	11.50"



For all drawer heights		
PART NO.	COMPTS.	CMPT. WIDTH
HDR312-█	6	7.50"
	6	9.50"



For all drawer heights		
PART NO.	COMPTS.	CMPT. WIDTH
HDR415-█	6	5.50"
	9	7.75"



For all drawer heights		
PART NO.	COMPTS.	CMPT. WIDTH
HDR518-█	18	5.50"



For drawer heights 75 through 200		
PART NO.	COMPTS.	CMPT. WIDTH
HDR-LR207-█	3	3.75"
	2	5.75"
	2	7.75"



For drawer heights 75 through 200		
PART NO.	COMPTS.	CMPT. WIDTH
HDR621-█	15	5.25"
	6	4.50"

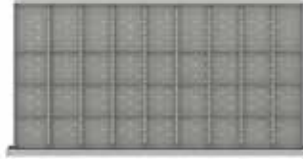

For drawer heights 75 through 200		
PART NO.	COMPTS.	CMPT. WIDTH
HDR836-█	36	3.50"



For drawer heights 75 and 100		
PART NO.	COMPTS.	CMPT. SIZE
HDR024-█	12	6" x 6"
	12	3" x 6"



For drawer heights 75 and 100		
PART NO.	COMPTS.	CMPT. SIZE
HDR036-█	36	3" x 6"



For drawer height 75		
PART NO.	COMPTS.	CMPT. WIDTH
HDR-SG432	6	2.75"
	10	1.75"
	15	1.25"

How to order an MS Width Preconfigured Drawer Interior Set

To order the drawer interior sets shown on this page, use the part number in the chart and add the drawer height in place of the green box.

EXAMPLE: to order an MSDR312 drawer interior set for a 100 height (3") drawer, the part ordering number would be **MSDR312-100**.

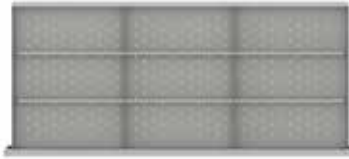

For all drawer heights		
PART NO.	COMPTS.	CMPT. WIDTH
MSDR-LR209-■	9	5.54"



For all drawer heights		
PART NO.	COMPTS.	CMPT. WIDTH
MSDR-LR210-■	4	3.53"
	3	5.54"
	3	7.55"



For all drawer heights		
PART NO.	COMPTS.	CMPT. WIDTH
MSDR-LR312-■	10	3.53"
	2	5.54"



For all drawer heights		
PART NO.	COMPTS.	CMPT. WIDTH
MSDR207-■	2	23.61"
	3	6.21"
	2	11.56"



For drawer heights 75 through 200		
PART NO.	COMPTS.	CMPT. WIDTH
MSDR310-■	2	17.59"
	3	5.54"
	3	6.21"
	2	11.56"



For all drawer heights		
PART NO.	COMPTS.	CMPT. WIDTH
MSDR312-■	3	6.21"
	9	11.56"



For all drawer heights		
PART NO.	COMPTS.	CMPT. WIDTH
MSDR413-■	3	5.54"
	3	6.21"
	3	7.55"
	2	9.56"
	2	11.56"



For drawer heights 75 through 200		
PART NO.	COMPTS.	CMPT. WIDTH
MSDR415-■	3	6.21"
	6	9.55"
	6	9.56"



For drawer heights 75 through 200		
PART NO.	COMPTS.	CMPT. WIDTH
MSDR517-■	4	3.53"
	3	5.54"
	3	6.24"
	5	7.55"
	2	9.56"



For drawer heights 75 through 200		
PART NO.	COMPTS.	CMPT. WIDTH
MSDR518-■	12	6.21"
	6	7.55"



For drawer heights 75 through 200		
PART NO.	COMPTS.	CMPT. SIZE
MSDR621-■	18	5.54"
	3	6.21"



For drawer heights 75 through 200		
PART NO.	COMPTS.	CMPT. SIZE
MSDR724-■	24	4.87"



For drawer heights 75 through 200		
PART NO.	COMPTS.	CMPT. SIZE
MSDR827-■	24	4.20"
	3	4.87"

How to order an HT Width Preconfigured Drawer Interior Set

To order the drawer interior sets shown on this page, use the part number in the chart and add the drawer height in place of the green box.

EXAMPLE: to order an HTR312 drawer interior set for a 100 height (3") drawer, the part ordering number would be **HTDR312-100**.



For all drawer heights		
PART NO.	COMPTS.	CMPT. WIDTH
HTDR-LR106-█	3	7.55"
	3	9.56"

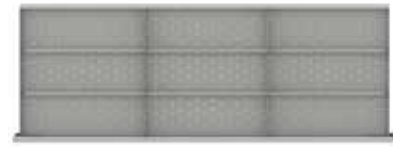

For all drawer heights		
PART NO.	COMPTS.	CMPT. WIDTH
HTDR-LR209-█	9	5.50"



For all drawer heights		
PART NO.	COMPTS.	CMPT. WIDTH
HTDR-LR312-█	10	3.53"
	2	5.54"

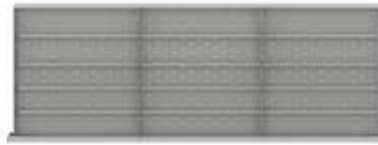

For drawer heights 75 through 250		
PART NO.	COMPTS.	CMPT. WIDTH
HTDR-LR415-█	9	2.86"
	6	3.53"



For all drawer heights		
PART NO.	COMPTS.	CMPT. WIDTH
HTDR410-█	8	9.56"
	2	11.56"

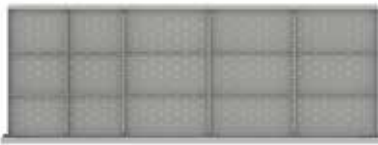

For all drawer heights		
PART NO.	COMPTS.	CMPT. WIDTH
HTDR415-█	6	7.55"
	9	11.56"



For all drawer heights		
PART NO.	COMPTS.	CMPT. WIDTH
HTDR518-█	12	7.55"
	6	9.56"



For all drawer heights		
PART NO.	COMPTS.	CMPT. WIDTH
HTDR621-█	9	6.21"
	12	7.55"



For all drawer heights		
PART NO.	COMPTS.	CMPT. WIDTH
HTDR724-█	18	5.54"
	6	7.55"



For all drawer heights		
PART NO.	COMPTS.	CMPT. SIZE
HTDR827-█	9	4.87"
	18	5.54"



For all drawer heights		
PART NO.	COMPTS.	CMPT. SIZE
HTDR930-█	6	4.20"
	24	4.87"



For all drawer heights		
PART NO.	COMPTS.	CMPT. WIDTH
HTDR203-█	3	16.92"

Ordering a Preconfigured Lista cabinet or mobile cabinet takes just a few simple steps, and enables you to have a customized cabinet (down to the base, lock and paint color) without having to break a sweat.

STEPS TO ORDER A PRECONFIGURED FULL DEPTH CABINET



1 Select a cabinet part number:
If you want to include drawer interior sets in your preconfigured cabinet, select the part number with the "A."

PART NO.	DRWS.	COMPARTS.
SC0600-0301N- <input checked="" type="checkbox"/> <input checked="" type="checkbox"/> <input type="checkbox"/>	3	8
SC0600-0301NA- <input checked="" type="checkbox"/> <input checked="" type="checkbox"/> <input type="checkbox"/>	3	8

2 Select base type **3 Select lock type** **4 Select paint color**

- | | | |
|--|--|---|
| <input checked="" type="checkbox"/> Select base type | <input checked="" type="checkbox"/> Select lock type | <input type="checkbox"/> Select paint color |
| NB= No Base | NL= No Lock | BE=Beige |
| 2LB= 2" Leveling Base | RG= Individual | BB=Bright Blue |
| 4LB= 4" Leveling Base | KA= Keyed-alike | BK=Black |
| 6LB= 6" Leveling Base | MA= Master | CB=Classic Blue |
| FT = Fork Truck Base | KP = Keypad Lock | GR=Dark Gray |
| 2FB = 2" Frame Base | | GG=Green |
| 4FB = 4" Frame Base | | LG=Light Gray |
| 6FB = 6" Frame Base | | NR=Red |
| | | SN=Sand |
| | | FW=White |

To see Footprints go to page 80–81.



Mobile MP cabinets make perfect toolboxes.



MW cabinets with stainless steel counter top.





Row of SC cabinets with plastic laminate counter top.

MODEL 600 FULL DEPTH CABINET COMBINATIONS (28.5" DEEP X 27.5" HEIGHT)

■ Select: Base ■ Select: Lock □ Select: Color

See page 40 for details.

		Cabinet Width	NW-16.85" Wide	MP-22.20" Wide	SC-28.23" Wide
 <p>5" 5" 11"</p> <p>0600-0301</p>	Drawer Capacities		165 lbs. (75kg)	440 lbs. (200kg)	440 lbs. (200kg)
	Drawers Usable Ht. (Points)		NW	MP	SC
	5.12" (150)	NWDR104-150	MPDR209-150	DR209-150	
	5.12" (150)	NWDR104-150	MPDR209-150	DR104-150	
	11.02" (300)	File Drawer	MPDR104-300	DR104-300	
	Cabinets				
	Without interiors	NW0600-0301N- <input type="checkbox"/>	MP0600-0301F- <input type="checkbox"/>	SC0600-0301F- <input type="checkbox"/>	
	With Interiors	NW0600-0301NA- <input type="checkbox"/>	MP0600-0301FA- <input type="checkbox"/>	SC0600-0301FA- <input type="checkbox"/>	
 <p>2" 3" 4" 11"</p> <p>0600-0401</p>	Drawers Usable Ht. (Points)		NW	MP	SC
	2.17" (75)	NWDR018-75	MPDR316-75	DR420-75	
	3.15" (100)	NWDR212-100	MPDR209-100	DR316-100	
	4.13" (125)	NWDR104-100	MPDR104-100	DR209-100	
	11.02" (300)	File Drawer	-	DR104-300	
	Cabinets				
	Without interiors	NW0600-0401N- <input type="checkbox"/>	MP0600-0401F- <input type="checkbox"/>	SC0600-0401F- <input type="checkbox"/>	
	With Interiors	NW0600-0401NA- <input type="checkbox"/>	MP0600-0401FA- <input type="checkbox"/>	SC0600-0401FA- <input type="checkbox"/>	
 <p>3" 5" 5" 7"</p> <p>0600-0402</p>	Drawers Usable Ht. (Points)		NW	MP	SC
	3.15" (100)	NWDR212-100	MPDR316-100	DR420-100	
	5.12" (150)	NWDR104-150	MPDR209-150	DR316-150	
	5.12" (150)	NWDR104-150	MPDR104-150	DR316-150	
	7.09" (200)	NWDR104-200	MPDR104-200	DR209-200	
	Cabinets				
	Without interiors	NW0600-0402N- <input type="checkbox"/>	MP0600-0402F- <input type="checkbox"/>	SC0600-0402F- <input type="checkbox"/>	
	With Interiors	NW0600-0402NA- <input type="checkbox"/>	MP0600-0402FA- <input type="checkbox"/>	SC0600-0402FA- <input type="checkbox"/>	
 <p>2" 2" 3" 5" 7"</p> <p>0600-0501</p>	Drawers Usable Ht. (Points)		NW	MP	SC
	2.17" (75)	NWDR018-75	MPDR316-75	DR420-75	
	2.17" (75)	NWDR212-75	MPDR316-75	DR316-75	
	3.15" (100)	NWDR212-100	MPDR209-100	DR316-100	
	5.12" (150)	NWDR104-150	MPDR104-150	DR209-150	
	7.09" (200)	NWDR104-200	MPDR104-200	DR209-200	
	Cabinets				
	Without interiors	NW0600-0501N- <input type="checkbox"/>	MP0600-0501F- <input type="checkbox"/>	SC0600-0501F- <input type="checkbox"/>	
	With Interiors	NW0600-0501NA- <input type="checkbox"/>	MP0600-0501FA- <input type="checkbox"/>	SC0600-0501FA- <input type="checkbox"/>	

See pages 66-75 for drawer layout detail.

EW-34.25" Wide 440 lbs. (200kg)	HW-40.28" Wide 440 lbs. (200kg)	MW-46.97" Wide 440 lbs. (200kg)	DW-56.34" Wide 440 lbs. (200kg)
EW EWDR207-150 EWDR-LR207-150 EWDR104-300	HW HWDR-LR312-150 HWDR-LR312-150 HWDR203-300	MW MWDR-LR209-150 MWDR-LR209-150 MWDR-LR106-300	DW DWDR-LR312-150 DWDR-LR209-150 DWDR-LR106-300
EW0600-0301F- <input type="checkbox"/> <input type="checkbox"/> <input type="checkbox"/> EW0600-0301FA- <input type="checkbox"/> <input type="checkbox"/> <input type="checkbox"/>	HW0600-0301F- <input type="checkbox"/> <input type="checkbox"/> <input type="checkbox"/> HW0600-0301FA- <input type="checkbox"/> <input type="checkbox"/> <input type="checkbox"/>	MW0600-0301F- <input type="checkbox"/> <input type="checkbox"/> <input type="checkbox"/> MW0600-0301FA- <input type="checkbox"/> <input type="checkbox"/> <input type="checkbox"/>	DW0600-0301F- <input type="checkbox"/> <input type="checkbox"/> <input type="checkbox"/> DW0600-0301FA- <input type="checkbox"/> <input type="checkbox"/> <input type="checkbox"/>
EW EWDR020-75 EWDR310-100 EWDR-LR312-100 EWDR207-300	HW HWDR036-75 HWDR312-100 HWDR-LR312-100 HWDR-LR106-300	MW MWDR-LR415-75 MWDR-LR209-100 MWDR-LR209-100 MWDR-LR106-300	DW DWDR-LR415-75 DWDR-LR209-100 DWDR-LR209-100 DWDR-LR106-300
EW0600-0401F- <input type="checkbox"/> <input type="checkbox"/> <input type="checkbox"/> EW0600-0401FA- <input type="checkbox"/> <input type="checkbox"/> <input type="checkbox"/>	HW0600-0401F- <input type="checkbox"/> <input type="checkbox"/> <input type="checkbox"/> HW0600-0401FA- <input type="checkbox"/> <input type="checkbox"/> <input type="checkbox"/>	MW0600-0401F- <input type="checkbox"/> <input type="checkbox"/> <input type="checkbox"/> MW0600-0401FA- <input type="checkbox"/> <input type="checkbox"/> <input type="checkbox"/>	DW0600-0401F- <input type="checkbox"/> <input type="checkbox"/> <input type="checkbox"/> DW0600-0401FA- <input type="checkbox"/> <input type="checkbox"/> <input type="checkbox"/>
EW EWDR-LR312-100 EWDR-LR207-150 EWDR-LR207-150 EWDR207-200	HW HWDR628-100 HWDR312-150 HWDR312-150 HWDR-LR106-200	MW MWDR-LR312-100 MWDR-LR209-150 MWDR-LR209-150 MWDR-LR106-200	DW DWDR-LR312-100 DWDR-LR209-150 DWDR-LR209-150 DWDR-LR106-200
EW0600-0402F- <input type="checkbox"/> <input type="checkbox"/> <input type="checkbox"/> EW0600-0402FA- <input type="checkbox"/> <input type="checkbox"/> <input type="checkbox"/>	HW0600-0402F- <input type="checkbox"/> <input type="checkbox"/> <input type="checkbox"/> HW0600-0402FA- <input type="checkbox"/> <input type="checkbox"/> <input type="checkbox"/>	MW0600-0402F- <input type="checkbox"/> <input type="checkbox"/> <input type="checkbox"/> MW0600-0402FA- <input type="checkbox"/> <input type="checkbox"/> <input type="checkbox"/>	DW0600-0402F- <input type="checkbox"/> <input type="checkbox"/> <input type="checkbox"/> DW0600-0402FA- <input type="checkbox"/> <input type="checkbox"/> <input type="checkbox"/>
EW EWDR518-75 EWDR415-75 EWDR415-100 EWDR212-150 EWDR212-200	HW HWDR628-75 HWDR-LR312-75 HWDR524-100 HWDR312-150 HWDR-LR106-200	MW MWDR-LR415-75 MWDR-LR415-75 MWDR-LR312-100 MWDR-LR209-150 MWDR-LR106-200	DW DWDR-LR518-75 DWDR-LR415-75 DWDR-LR312-100 DWDR-LR209-150 DWDR-LR106-200
EW0600-0501F- <input type="checkbox"/> <input type="checkbox"/> <input type="checkbox"/> EW0600-0501FA- <input type="checkbox"/> <input type="checkbox"/> <input type="checkbox"/>	HW0600-0501F- <input type="checkbox"/> <input type="checkbox"/> <input type="checkbox"/> HW0600-0501FA- <input type="checkbox"/> <input type="checkbox"/> <input type="checkbox"/>	MW0600-0501F- <input type="checkbox"/> <input type="checkbox"/> <input type="checkbox"/> MW0600-0501FA- <input type="checkbox"/> <input type="checkbox"/> <input type="checkbox"/>	DW0600-0501F- <input type="checkbox"/> <input type="checkbox"/> <input type="checkbox"/> DW0600-0501FA- <input type="checkbox"/> <input type="checkbox"/> <input type="checkbox"/>

Model 600 Cabinet Combinations
continued on next page.

































MODEL 600 FULL DEPTH CABINET COMBINATIONS (28.5" DEEP X 27.5" HEIGHT)

■ Select: Base ■ Select: Lock □ Select: Color

See page 40 for details.

		Cabinet Width	NW-16.85" Wide	MP-22.20" Wide	SC-28.23" Wide
 <p>0600-0502</p>	Drawer Capacities		165 lbs. (75kg)	440 lbs. (200kg)	440 lbs. (200kg)
	Drawers Usable Ht. (Points)		NW	MP	SC
	3"	3.15" (100)	NWDR016-100	MPDR316-100	DR420-100
	3"	3.15" (100)	NWDR212-100	MPDR209-100	DR420-100
	5"	3.15" (100)	NWDR212-100	MPDR209-100	DR316-100
	5"	5.12" (150)	NWDR107-150	MPDR104-150	DR316-150
	5.12" (150)	NWDR107-150	MPDR104-150	DR209-150	
	Cabinets				
	Without interiors	NW0600-0502N- <input type="checkbox"/>	MP0600-0502F- <input type="checkbox"/>	SC0600-0502F- <input type="checkbox"/>	
	With Interiors	NW0600-0502NA- <input type="checkbox"/>	MP0600-0502FA- <input type="checkbox"/>	SC0600-0502FA- <input type="checkbox"/>	
 <p>0600-0601</p>	Drawers Usable Ht. (Points)		NW	MP	SC
	2"	2.17" (75)	NWDR105-75	MPDR028-75	DR209-75
	2"	2.17" (75)	NWDR212-75	MPDR316-75	DR420-75
	3"	3.15" (100)	NWDR107-100	MPDR316-100	DR420-100
	3"	3.15" (100)	NWDR107-100	MPDR209-100	DR316-100
	5"	3.15" (100)	NWDR107-100	MPDR209-100	DR316-100
	5.12" (150)	NWDR104-150	MPDR104-150	DR209-150	
	Cabinets				
	Without interiors	NW0600-0601N- <input type="checkbox"/>	MP0600-0601F- <input type="checkbox"/>	SC0600-0601F- <input type="checkbox"/>	
	With Interiors	NW0600-0601NA- <input type="checkbox"/>	MP0600-0601FA- <input type="checkbox"/>	SC0600-0601FA- <input type="checkbox"/>	
 <p>0600-0701</p>	Drawers Usable Ht. (Points)		NW	MP	SC
	2"	2.17" (75)	NWDR212-75	MPDR316-75	DR036-75
	2"	2.17" (75)	NWDR212-75	MPDR316-75	DR036-75
	2"	2.17" (75)	NWDR107-75	MPDR209-75	DR524-75
	3"	2.17" (75)	NWDR107-75	MPDR209-75	DR524-75
	3"	3.15" (100)	NWDR107-100	MPDR209-100	DR420-100
	3.15" (100)	NWDR107-100	MPDR209-100	DR420-100	
	3.15" (100)	NWDR107-100	MPDR209-100	DR420-100	
	Cabinets				
	Without interiors	NW0600-0701N- <input type="checkbox"/>	MP0600-0701F- <input type="checkbox"/>	SC0600-0701F- <input type="checkbox"/>	
	With Interiors	NW0600-0701NA- <input type="checkbox"/>	MP0600-0701FA- <input type="checkbox"/>	SC0600-0701FA- <input type="checkbox"/>	
 <p>0600-0703</p>	Drawers Usable Ht. (Points)		NW	MP	SC
	2"	2.17" (75)	NWDR024-75	MPDR028-75	DR524-75
	2"	2.17" (75)	NWDR012-75	MPDR018-75	DR524-75
	2"	2.17" (75)	NWDR209-75	MPDR312-75	DR420-75
	2"	2.17" (75)	NWDR209-75	MPDR312-75	DR420-75
	5"	2.17" (75)	NWDR108-75	MPDR209-75	DR316-75
	2.17" (75)	NWDR108-75	MPDR209-75	DR316-75	
	5.12" (150)	NWDR104-150	MPDR108-150	DR209-150	
	Cabinets				
	Without interiors	NW0600-0703N- <input type="checkbox"/>	MP0600-0703F- <input type="checkbox"/>	SC0600-0703F- <input type="checkbox"/>	
	With Interiors	NW0600-0703NA- <input type="checkbox"/>	MP0600-0703FA- <input type="checkbox"/>	SC0600-0703FA- <input type="checkbox"/>	

See pages 66-75 for drawer layout detail.

EW-34.25" Wide	HW-40.28" Wide	MW-46.97" Wide	DW-56.34" Wide
440 lbs. (200kg)	440 lbs. (200kg)	440 lbs. (200kg)	440 lbs. (200kg)
EW	HW	MW	DW
EWDR-LR312-100 EWDR-LR312-100 EWDR-LR207-100 EWDR212-150 EWDR212-150	HWDR628-100 HWDR420-100 HWDR-LR209-100 HWDR209-150 HWDR209-150	MWDR-LR312-100 MWDR-LR312-100 MWDR-LR312-100 MWDR-LR209-150 MWDR-LR106-150	DWDR-LR312-100 DWDR-LR312-100 DWDR-LR312-100 DWDR-LR209-150 DWDR-LR106-150
EW0600-0502F-  EW0600-0502FA- 	HW0600-0502F-  HW0600-0502FA- 	MW0600-0502F-  MW0600-0502FA- 	DW0600-0502F-  DW0600-0502FA- 
EW	HW	MW	DW
EWDR310-75 EWDR310-75 EWDR207-100 EWDR207-100 EWDR207-100 EWDR104-150	HWDR524-75 HWDR-LR312-75 HWDR312-100 HWDR312-100 HWDR312-100 HWDR209-150	MWDR-LR209-75 MWDR-LR415-75 MWDR-LR415-100 MWDR-LR312-100 MWDR-LR312-100 MWDR-LR209-150	DWDR-LR209-75 DWDR-LR415-75 DWDR-LR415-100 DWDR-LR312-100 DWDR-LR312-100 DWDR-LR209-150
EW0600-0601F-  EW0600-0601FA- 	HW0600-0601F-  HW0600-0601FA- 	MW0600-0601F-  MW0600-0601FA- 	DW0600-0601F-  DW0600-0601FA- 
EW	HW	MW	DW
EWDR040-75 EWDR518-75 EWDR518-75 EWDR415-75 EWDR415-100 EWDR310-100 EWDR310-100	HWDR628-75 HWDR628-75 HWDR524-75 HWDR524-75 HWDR420-100 HWDR420-100 HWDR420-100	MWDR-LR312-75 MWDR-LR312-75 MWDR-LR209-75 MWDR-LR209-75 MWDR-LR209-100 MWDR-LR209-100 MWDR-LR209-100	DWDR-LR518-75 DWDR-LR312-75 DWDR-LR312-75 DWDR-LR209-75 DWDR-LR209-100 DWDR-LR209-100 DWDR-LR209-100
EW0600-0701F-  EW0600-0701FA- 	HW0600-0701F-  HW0600-0701FA- 	MW0600-0701F-  MW0600-0701FA- 	DW0600-0701F-  DW0600-0701FA- 
EW	HW	MW	DW
EWDR-LR518-75 EWDR-LR518-75 EWDR518-75 EWDR518-75 EWDR415-75 EWDR415-75 EWDR207-150	HWDR036-75 HWDR024-75 HWDR628-75 HWDR420-75 HWDR209-75 HWDR-LR312-75 HWDR-LR209-150	MWDR-LR415-75 MWDR-LR415-75 MWDR-LR312-75 MWDR-LR312-75 MWDR-LR209-75 MWDR-LR209-75 MWDR-LR106-150	DWDR-LR518-75 DWDR-LR415-75 DWDR-LR415-75 DWDR-LR312-75 DWDR-LR312-75 DWDR-LR209-75 DWDR-LR209-150
EW0600-0703F-  EW0600-0703FA- 	HW0600-0703F-  HW0600-0703FA- 	MW0600-0703F-  MW0600-0703FA- 	DW0600-0703F-  DW0600-0703FA- 

MODEL 750 FULL DEPTH CABINET COMBINATIONS (28.5" DEEP X 33.5" HEIGHT)

■ Select: Base ■ Select: Lock □ Select: Color

See page 40 for details.

		Cabinet Width	NW-16.85" Wide	MP-22.20" Wide	SC-28.23" Wide
 <p>0750-0401</p>	Drawer Capacities		165 lbs. (75kg)	440 lbs. (200kg)	440 lbs. (200kg)
	Drawers Usable Ht. (Points)		NW	MP	SC
	5"	5.12" (150)	NWDR107-150	MPDR209-150	DR316-150
	5"	5.12" (150)	NWDR104-150	MPDR104-150	DR316-150
	7"	7.09" (200)	NWDR107-200	MPDR104-200	DR209-200
9"	9.06" (250)	NWDR104-250	MPDR104-250	DR104-250	
	Cabinets				
	Without interiors	NW0750-0401N- <input type="checkbox"/> <input type="checkbox"/> <input type="checkbox"/>	MP0750-0401F- <input type="checkbox"/> <input type="checkbox"/> <input type="checkbox"/>	SC0750-0401F- <input type="checkbox"/> <input type="checkbox"/> <input type="checkbox"/>	
	With Interiors	NW0750-0401NA- <input type="checkbox"/> <input type="checkbox"/> <input type="checkbox"/>	MP0750-0401FA- <input type="checkbox"/> <input type="checkbox"/> <input type="checkbox"/>	SC0750-0401FA- <input type="checkbox"/> <input type="checkbox"/> <input type="checkbox"/>	
 <p>0750-0402</p>	Drawers Usable Ht. (Points)		NW	MP	SC
	3"	3.15" (100)	NWDR212-100	MPDR316-100	DR016-100
	5"	5.12" (150)	NWDR108-150	MPDR209-150	DR316-150
	7"	7.09" (200)	NWDR108-200	MPDR104-200	DR206-200
	11"	11.02" (300)	-	-	-
	Cabinets				
	Without interiors	NW0750-0402N- <input type="checkbox"/> <input type="checkbox"/> <input type="checkbox"/>	MP0750-0402F- <input type="checkbox"/> <input type="checkbox"/> <input type="checkbox"/>	SC0750-0402F- <input type="checkbox"/> <input type="checkbox"/> <input type="checkbox"/>	
	With Interiors	NW0750-0402NA- <input type="checkbox"/> <input type="checkbox"/> <input type="checkbox"/>	MP0750-0402FA- <input type="checkbox"/> <input type="checkbox"/> <input type="checkbox"/>	SC0750-0402FA- <input type="checkbox"/> <input type="checkbox"/> <input type="checkbox"/>	
 <p>0750-0404</p>	Drawers Usable Ht. (Points)		NW	MP	SC
	5"	5.12" (150)	NWDR104-150	MPDR209-150	DR312-150
	7"	7.09" (200)	NWDR106-200	MPDR206-200	DR209-200
	7"	7.09" (200)	NWDR106-200	MPDR206-200	DR104-200
	7"	7.09" (200)	NWDR105-200	MPDR206-200	DR104-200
	Cabinets				
	Without interiors	NW0750-0404N- <input type="checkbox"/> <input type="checkbox"/> <input type="checkbox"/>	MP0750-0404F- <input type="checkbox"/> <input type="checkbox"/> <input type="checkbox"/>	SC0750-0404F- <input type="checkbox"/> <input type="checkbox"/> <input type="checkbox"/>	
	With Interiors	NW0750-0404NA- <input type="checkbox"/> <input type="checkbox"/> <input type="checkbox"/>	MP0750-0404FA- <input type="checkbox"/> <input type="checkbox"/> <input type="checkbox"/>	SC0750-0404FA- <input type="checkbox"/> <input type="checkbox"/> <input type="checkbox"/>	
 <p>0750-0501</p>	Drawers Usable Ht. (Points)		NW	MP	SC
	2"	2.17" (75)	NWDR018-75	MPDR430-75	DR524-75
	3"	3.15" (100)	NWDR212-100	MPDR316-100	DR420-100
	4"	4.13" (125)	NWDR104-100	MPDR316-100	DR420-100
	5"	5.12" (150)	NWDR104-150	MPDR209-150	DR316-150
11"	11.02" (300)	File Drawer	-	DR106-300	
	Cabinets				
	Without interiors	NW0750-0501N- <input type="checkbox"/> <input type="checkbox"/> <input type="checkbox"/>	MP0750-0501F- <input type="checkbox"/> <input type="checkbox"/> <input type="checkbox"/>	SC0750-0501F- <input type="checkbox"/> <input type="checkbox"/> <input type="checkbox"/>	
	With Interiors	NW0750-0501NA- <input type="checkbox"/> <input type="checkbox"/> <input type="checkbox"/>	MP0750-0501FA- <input type="checkbox"/> <input type="checkbox"/> <input type="checkbox"/>	SC0750-0501FA- <input type="checkbox"/> <input type="checkbox"/> <input type="checkbox"/>	

See pages 66-75 for drawer layout detail.



EW-34.25" Wide 440 lbs. (200kg)	HW-40.28" Wide 440 lbs. (200kg)	MW-46.97" Wide 440 lbs. (200kg)	DW-56.34" Wide 440 lbs. (200kg)
EW EWDR-LR207-150 EWDR-LR207-150 EWDR-LR312-200 EWDR-LR312-250	HW HWDR-LR209-150 HWDR-LR209-150 HWDR-LR106-200 HWDR-LR106-250	MW MWDR-LR209-150 MWDR-LR209-150 MWDR-LR106-200 MWDR-LR106-250	DW DWDR-LR209-150 DWDR-LR209-150 DWDR-LR106-200 DWDR-LR106-250
EW0750-0401F- <input type="checkbox"/> <input type="checkbox"/> <input type="checkbox"/> EW0750-0401FA- <input type="checkbox"/> <input type="checkbox"/> <input type="checkbox"/>	HW0750-0401F- <input type="checkbox"/> <input type="checkbox"/> <input type="checkbox"/> HW0750-0401FA- <input type="checkbox"/> <input type="checkbox"/> <input type="checkbox"/>	MW0750-0401F- <input type="checkbox"/> <input type="checkbox"/> <input type="checkbox"/> MW0750-0401FA- <input type="checkbox"/> <input type="checkbox"/> <input type="checkbox"/>	DW0750-0401F- <input type="checkbox"/> <input type="checkbox"/> <input type="checkbox"/> DW0750-0401FA- <input type="checkbox"/> <input type="checkbox"/> <input type="checkbox"/>
EW EWDR212-100 EWDR212-150 EWDR207-200 EWDR104-300	HW HWDR-LR312-100 HWDR-LR209-150 HWDR209-200 HWDR203-300	MW MWDR-LR312-100 MWDR-LR209-150 MWDR312-200 MWDR203-300	DW DWDR-LR415-100 DWDR-LR415-150 DWDR-LR312-200 DWDR203-300
EW0750-0402F- <input type="checkbox"/> <input type="checkbox"/> <input type="checkbox"/> EW0750-0402FA- <input type="checkbox"/> <input type="checkbox"/> <input type="checkbox"/>	HW0750-0402F- <input type="checkbox"/> <input type="checkbox"/> <input type="checkbox"/> HW0750-0402FA- <input type="checkbox"/> <input type="checkbox"/> <input type="checkbox"/>	MW0750-0402F- <input type="checkbox"/> <input type="checkbox"/> <input type="checkbox"/> MW0750-0402FA- <input type="checkbox"/> <input type="checkbox"/> <input type="checkbox"/>	DW0750-0402F- <input type="checkbox"/> <input type="checkbox"/> <input type="checkbox"/> DW0750-0402FA- <input type="checkbox"/> <input type="checkbox"/> <input type="checkbox"/>
EW EWDR310-150 EWDR310-200 EWDR-LR312-200 EWDR-LR207-200	HW HWDR-LR209-150 HWDR-LR209-200 HWDR-LR106-200 HWDR-LR106-200	MW MWDR-LR209-150 MWDR-LR209-200 MWDR-LR106-200 MWDR-LR106-200	DW DWDR-LR209-150 DWDR-LR209-200 DWDR-LR106-200 DWDR-LR106-200
EW0750-0404F- <input type="checkbox"/> <input type="checkbox"/> <input type="checkbox"/> EW0750-0404FA- <input type="checkbox"/> <input type="checkbox"/> <input type="checkbox"/>	HW0750-0404F- <input type="checkbox"/> <input type="checkbox"/> <input type="checkbox"/> HW0750-0404FA- <input type="checkbox"/> <input type="checkbox"/> <input type="checkbox"/>	MW0750-0404F- <input type="checkbox"/> <input type="checkbox"/> <input type="checkbox"/> MW0750-0404FA- <input type="checkbox"/> <input type="checkbox"/> <input type="checkbox"/>	DW0750-0404F- <input type="checkbox"/> <input type="checkbox"/> <input type="checkbox"/> DW0750-0404FA- <input type="checkbox"/> <input type="checkbox"/> <input type="checkbox"/>
EW EWDR-LR312-75 EWDR-LR312-100 EWDR-LR207-100 EWDR-LR207-150 -	HW HWDR420-75 HWDR312-100 HWDR312-100 HWDR-LR209-150 HWDR-LR106-300	MW MWDR-LR415-75 MWDR-LR312-100 MWDR-LR209-100 MWDR-LR209-150 MWDR-LR106-300	DW DWDR-LR415-75 DWDR-LR312-100 DWDR-LR209-100 DWDR-LR209-150 DWDR-LR106-300
EW0750-0501F- <input type="checkbox"/> <input type="checkbox"/> <input type="checkbox"/> EW0750-0501FA- <input type="checkbox"/> <input type="checkbox"/> <input type="checkbox"/>	HW0750-0501F- <input type="checkbox"/> <input type="checkbox"/> <input type="checkbox"/> HW0750-0501FA- <input type="checkbox"/> <input type="checkbox"/> <input type="checkbox"/>	MW0750-0501F- <input type="checkbox"/> <input type="checkbox"/> <input type="checkbox"/> MW0750-0501FA- <input type="checkbox"/> <input type="checkbox"/> <input type="checkbox"/>	DW0750-0501F- <input type="checkbox"/> <input type="checkbox"/> <input type="checkbox"/> DW0750-0501FA- <input type="checkbox"/> <input type="checkbox"/> <input type="checkbox"/>

Model 750 Cabinet Combinations continued on next page.

MODEL 750 FULL DEPTH CABINET COMBINATIONS (28.5" DEEP X 33.5" HEIGHT)

■ Select: Base ■ Select: Lock □ Select: Color

See page 40 for details.

		Cabinet Width	NW-16.85" Wide	MP-22.20" Wide	SC-28.23" Wide
 <p>0750-0502</p>	Drawer Capacities		165 lbs. (75kg)	440 lbs. (200kg)	440 lbs. (200kg)
	Drawers Usable Ht. (Points)		NW	MP	SC
	3"	3.15" (100)	NWDR212-100	MPDR316-100	DR420-100
	3"	3.15" (100)	NWDR212-100	MPDR209-100	DR316-100
	5"	5.12" (150)	NWDR104-150	MPDR209-150	DR316-150
5"	5.12" (150)	NWDR104-150	MPDR104-150	DR209-150	
9"	9.06" (250)	-	MPDR104-250	DR209-250	
Cabinets					
Without interiors			NW0750-0502N- <input type="checkbox"/> <input type="checkbox"/>	MP0750-0502F- <input type="checkbox"/> <input type="checkbox"/>	SC0750-0502F- <input type="checkbox"/> <input type="checkbox"/>
With Interiors			NW0750-0502NA- <input type="checkbox"/> <input type="checkbox"/>	MP0750-0502FA- <input type="checkbox"/> <input type="checkbox"/>	SC0750-0502FA- <input type="checkbox"/> <input type="checkbox"/>
 <p>0750-0505</p>	Drawers Usable Ht. (Points)		NW	MP	SC
	2"	2.17" (75)	NWDR105-75	MPDR316-75	DR420-75
	3"	3.15" (100)	NWDR105-100	MPDR209-100	DR316-100
	4"	4.13" (125)	NWDR105-100	MPDR209-100	DR316-100
	7"	7.09" (200)	NWDR104-200	MPDR206-200	DR312-200
9"	9.06" (250)	NWDR104-250	MPDR206-250	DR312-250	
Cabinets					
Without interiors			NW0750-0505N- <input type="checkbox"/> <input type="checkbox"/>	MP0750-0505F- <input type="checkbox"/> <input type="checkbox"/>	SC0750-0505F- <input type="checkbox"/> <input type="checkbox"/>
With Interiors			NW0750-0505NA- <input type="checkbox"/> <input type="checkbox"/>	MP0750-0505FA- <input type="checkbox"/> <input type="checkbox"/>	SC0750-0505FA- <input type="checkbox"/> <input type="checkbox"/>
 <p>0750-0601</p>	Drawers Usable Ht. (Points)		NW	MP	SC
	2"	2.17" (75)	NWDR018-75	MPDR028-75	DR032-75
	2"	2.17" (75)	NWDR018-75	MPDR316-75	DR420-75
	3"	3.15" (100)	NWDR212-100	MPDR209-100	DR316-100
	5"	5.12" (150)	NWDR104-150	MPDR209-150	DR316-150
5"	5.12" (150)	NWDR104-150	MPDR104-150	DR106-150	
7"	7.09" (200)	NWDR104-200	MPDR104-200	DR104-200	
Cabinets					
Without interiors			NW0750-0601N- <input type="checkbox"/> <input type="checkbox"/>	MP0750-0601F- <input type="checkbox"/> <input type="checkbox"/>	SC0750-0601F- <input type="checkbox"/> <input type="checkbox"/>
With Interiors			NW0750-0601NA- <input type="checkbox"/> <input type="checkbox"/>	MP0750-0601FA- <input type="checkbox"/> <input type="checkbox"/>	SC0750-0601FA- <input type="checkbox"/> <input type="checkbox"/>
 <p>0750-0602</p>	Drawers Usable Ht. (Points)		NW	MP	SC
	2"	2.17" (75)	NWDR212-75	MPDR316-75	DR420-75
	2"	2.17" (75)	NWDR212-75	MPDR316-75	DR420-75
	3"	3.15" (100)	NWDR212-100	MPDR209-100	DR316-100
	3"	3.15" (100)	NWDR107-100	MPDR209-100	DR316-100
5"	5.12" (150)	NWDR107-150	MPDR104-150	DR209-150	
9"	9.06" (250)	NWDR104-250	MPDR104-250	DR209-250	
Cabinets					
Without interiors			NW0750-0602N- <input type="checkbox"/> <input type="checkbox"/>	MP0750-0602F- <input type="checkbox"/> <input type="checkbox"/>	SC0750-0602F- <input type="checkbox"/> <input type="checkbox"/>
With Interiors			NW0750-0602NA- <input type="checkbox"/> <input type="checkbox"/>	MP0750-0602FA- <input type="checkbox"/> <input type="checkbox"/>	SC0750-0602FA- <input type="checkbox"/> <input type="checkbox"/>

See pages 66-75 for drawer layout detail.



EW-34.25" Wide	HW-40.28" Wide	MW-46.97" Wide	DW-56.34" Wide
440 lbs. (200kg)	440 lbs. (200kg)	440 lbs. (200kg)	440 lbs. (200kg)
EW	HW	MW	DW
EWDR415-100 EWDR415-100 EWDR310-150 EWDR310-150 EWDR207-250	HWDR628-100 HWDR312-100 HWDR312-150 HWDR209-150 HWDR209-250	MWDR732-100 MWDR420-100 MWDR420-150 MWDR312-150 MWDR312-250	DWDR-LR518-100 DWDR-LR415-100 DWDR-LR415-150 DWDR-LR312-150 DWDR-LR312-250
EW0750-0502F- <input type="checkbox"/> <input type="checkbox"/> <input type="checkbox"/> EW0750-0502FA- <input type="checkbox"/> <input type="checkbox"/> <input type="checkbox"/>	HW0750-0502F- <input type="checkbox"/> <input type="checkbox"/> <input type="checkbox"/> HW0750-0502FA- <input type="checkbox"/> <input type="checkbox"/> <input type="checkbox"/>	MW0750-0502F- <input type="checkbox"/> <input type="checkbox"/> <input type="checkbox"/> MW0750-0502FA- <input type="checkbox"/> <input type="checkbox"/> <input type="checkbox"/>	DW0750-0502F- <input type="checkbox"/> <input type="checkbox"/> <input type="checkbox"/> DW0750-0502FA- <input type="checkbox"/> <input type="checkbox"/> <input type="checkbox"/>
EW	HW	MW	DW
EWDR518-75 EWDR-LR312-100 EWDR310-100 EWDR310-200 EWDR310-250	HWDR524-75 HWDR-LR312-100 HWDR312-100 HWDR209-200 HWDR209-250	MWDR628-75 MWDR-LR312-100 MWDR-LR312-100 MWDR-LR209-200 MWDR-LR209-250	DWDR-LR415-75 DWDR-LR415-100 DWDR-LR312-100 DWDR-LR312-200 DWDR-LR209-250
EW0750-0505F- <input type="checkbox"/> <input type="checkbox"/> <input type="checkbox"/> EW0750-0505FA- <input type="checkbox"/> <input type="checkbox"/> <input type="checkbox"/>	HW0750-0505F- <input type="checkbox"/> <input type="checkbox"/> <input type="checkbox"/> HW0750-0505FA- <input type="checkbox"/> <input type="checkbox"/> <input type="checkbox"/>	MW0750-0505F- <input type="checkbox"/> <input type="checkbox"/> <input type="checkbox"/> MW0750-0505FA- <input type="checkbox"/> <input type="checkbox"/> <input type="checkbox"/>	DW0750-0505F- <input type="checkbox"/> <input type="checkbox"/> <input type="checkbox"/> DW0750-0505FA- <input type="checkbox"/> <input type="checkbox"/> <input type="checkbox"/>
EW	HW	MW	DW
EWDR040-75 EWDR020-75 EWDR310-100 EWDR310-150 EWDR207-150 EWDR207-200	HWDR036-75 HWDR024-75 HWDR420-100 HWDR-LR209-150 HWDR-LR209-150 HWDR209-200	MWDR420-75 MWDR420-75 MWDR-LR312-100 MWDR-LR209-150 MWDR-LR209-150 MWDR-LR209-200	DWDR-LR415-75 DWDR-LR415-75 DWDR-LR312-100 DWDR-LR209-150 DWDR-LR209-150 DWDR-LR106-200
EW0750-0601F- <input type="checkbox"/> <input type="checkbox"/> <input type="checkbox"/> EW0750-0601FA- <input type="checkbox"/> <input type="checkbox"/> <input type="checkbox"/>	HW0750-0601F- <input type="checkbox"/> <input type="checkbox"/> <input type="checkbox"/> HW0750-0601FA- <input type="checkbox"/> <input type="checkbox"/> <input type="checkbox"/>	MW0750-0601F- <input type="checkbox"/> <input type="checkbox"/> <input type="checkbox"/> MW0750-0601FA- <input type="checkbox"/> <input type="checkbox"/> <input type="checkbox"/>	DW0750-0601F- <input type="checkbox"/> <input type="checkbox"/> <input type="checkbox"/> DW0750-0601FA- <input type="checkbox"/> <input type="checkbox"/> <input type="checkbox"/>
EW	HW	MW	DW
EWDR518-75 EWDR-LR312-75 EWDR415-100 EWDR-LR207-100 EWDR310-150 EWDR207-250	HWDR628-75 HWDR-LR312-75 HWDR524-100 HWDR-LR209-100 HWDR312-150 HWDR-LR106-250	MWDR732-75 MWDR-LR312-75 MWDR628-100 MWDR-LR209-100 MWDR420-150 MWDR203-250	DWDR836-75 DWDR-LR415-75 DWDR732-100 DWDR-LR312-100 DWDR524-150 DWDR203-250
EW0750-0602F- <input type="checkbox"/> <input type="checkbox"/> <input type="checkbox"/> EW0750-0602FA- <input type="checkbox"/> <input type="checkbox"/> <input type="checkbox"/>	HW0750-0602F- <input type="checkbox"/> <input type="checkbox"/> <input type="checkbox"/> HW0750-0602FA- <input type="checkbox"/> <input type="checkbox"/> <input type="checkbox"/>	MW0750-0602F- <input type="checkbox"/> <input type="checkbox"/> <input type="checkbox"/> MW0750-0602FA- <input type="checkbox"/> <input type="checkbox"/> <input type="checkbox"/>	DW0750-0602F- <input type="checkbox"/> <input type="checkbox"/> <input type="checkbox"/> DW0750-0602FA- <input type="checkbox"/> <input type="checkbox"/> <input type="checkbox"/>

Model 750 Cabinet Combinations
continued on next page.

MODEL 750 FULL DEPTH CABINET COMBINATIONS (28.5" DEEP X 33.5" HEIGHT)

■ Select: Base ■ Select: Lock □ Select: Color

See page 40 for details.

		Cabinet Width	NW-16.85" Wide	MP-22.20" Wide	SC-28.23" Wide
 <p>2" 2" 2" 2" 3" 5" 7"</p>	Drawer Capacities		165 lbs. (75kg)	440 lbs. (200kg)	440 lbs. (200kg)
	Drawers Usable Ht. (Points)		NW	MP	SC
	2.17" (75)		NWDR212-75	MPDR316-75	DR036-75
	2.17" (75)		NWDR212-75	MPDR316-75	DR016-75
	2.17" (75)		NWDR107-75	MPDR316-75	DR524-75
	2.17" (75)		NWDR107-75	MPDR316-75	DR524-75
	3.15" (100)		NWDR107-100	MPDR209-100	DR420-100
	5.12" (150)		NWDR104-150	MPDR206-150	DR316-150
	7.09" (200)		NWDR104-200	MPDR104-200	DR209-200
	Cabinets				
Without interiors		NW0750-0701N- <input type="checkbox"/> <input type="checkbox"/> <input type="checkbox"/>	MP0750-0701F- <input type="checkbox"/> <input type="checkbox"/> <input type="checkbox"/>	SC0750-0701F- <input type="checkbox"/> <input type="checkbox"/> <input type="checkbox"/>	
With Interiors		NW0750-0701NA- <input type="checkbox"/> <input type="checkbox"/> <input type="checkbox"/>	MP0750-0701FA- <input type="checkbox"/> <input type="checkbox"/> <input type="checkbox"/>	SC0750-0701FA- <input type="checkbox"/> <input type="checkbox"/> <input type="checkbox"/>	
 <p>2" 2" 3" 3" 3" 5" 5"</p>	Drawers Usable Ht. (Points)		NW	MP	SC
	2.17" (75)		NWDR018-75	MPDR028-75	DR036-75
	2.17" (75)		NWDR212-75	MPDR316-75	DR524-75
	3.15" (100)		NWDR212-100	MPDR316-100	DR420-100
	3.15" (100)		NWDR212-100	MPDR209-100	DR420-100
	3.15" (100)		NWDR108-100	MPDR209-100	DR312-100
	5.12" (150)		NWDR108-150	MPDR209-150	DR312-150
	5.12" (150)		NWDR108-150	MPDR104-150	DR209-150
	Cabinets				
	Without interiors		NW0750-0703N- <input type="checkbox"/> <input type="checkbox"/> <input type="checkbox"/>	MP0750-0703F- <input type="checkbox"/> <input type="checkbox"/> <input type="checkbox"/>	SC0750-0703F- <input type="checkbox"/> <input type="checkbox"/> <input type="checkbox"/>
With Interiors		NW0750-0703NA- <input type="checkbox"/> <input type="checkbox"/> <input type="checkbox"/>	MP0750-0703FA- <input type="checkbox"/> <input type="checkbox"/> <input type="checkbox"/>	SC0750-0703FA- <input type="checkbox"/> <input type="checkbox"/> <input type="checkbox"/>	
 <p>3" 3" 3" 3" 3" 3" 3" 5"</p>	Drawers Usable Ht. (Points)		NW	MP	SC
	3.15" (100)		NWDR008-100	MPDR012-100	DR420-100
	3.15" (100)		NWDR008-100	MPDR012-100	DR420-100
	3.15" (100)		NWDR209-100	MPDR312-100	DR312-100
	3.15" (100)		NWDR209-100	MPDR312-100	DR312-100
	3.15" (100)		NWDR107-100	MPDR209-100	DR209-100
	3.15" (100)		NWDR107-100	MPDR209-100	DR209-100
	5.12" (150)		NWDR105-150	MPDR206-150	DR209-150
	Cabinets				
	Without interiors		NW0750-0704N- <input type="checkbox"/> <input type="checkbox"/> <input type="checkbox"/>	MP0750-0704F- <input type="checkbox"/> <input type="checkbox"/> <input type="checkbox"/>	SC0750-0704F- <input type="checkbox"/> <input type="checkbox"/> <input type="checkbox"/>
With Interiors		NW0750-0704NA- <input type="checkbox"/> <input type="checkbox"/> <input type="checkbox"/>	MP0750-0704FA- <input type="checkbox"/> <input type="checkbox"/> <input type="checkbox"/>	SC0750-0704FA- <input type="checkbox"/> <input type="checkbox"/> <input type="checkbox"/>	
 <p>2" 2" 2" 2" 3" 3" 3" 5"</p>	Drawers Usable Ht. (Points)		NW	MP	SC
	2.17" (75)		NWDR212-75	MPDR028-75	DR036-75
	2.17" (75)		NWDR212-75	MPDR024-75	DR036-75
	2.17" (75)		NWDR107-75	MPDR018-75	DR420-75
	2.17" (75)		NWDR107-75	MPDR012-75	DR420-75
	3.15" (100)		NWDR104-100	MPDR104-100	DR316-100
	3.15" (100)		NWDR107-100	MPDR104-100	DR316-100
	3.15" (100)		NWDR107-100	MPDR104-100	DR209-100
	5.12" (150)		NWDR104-150	MPDR206-150	DR209-150
	Cabinets				
Without interiors		NW0750-0801N- <input type="checkbox"/> <input type="checkbox"/> <input type="checkbox"/>	MP0750-0801F- <input type="checkbox"/> <input type="checkbox"/> <input type="checkbox"/>	SC0750-0801F- <input type="checkbox"/> <input type="checkbox"/> <input type="checkbox"/>	
With Interiors		NW0750-0801NA- <input type="checkbox"/> <input type="checkbox"/> <input type="checkbox"/>	MP0750-0801FA- <input type="checkbox"/> <input type="checkbox"/> <input type="checkbox"/>	SC0750-0801FA- <input type="checkbox"/> <input type="checkbox"/> <input type="checkbox"/>	

See pages 66-75 for drawer layout detail.

EW-34.25" Wide	HW-40.28" Wide	MW-46.97" Wide	DW-56.34" Wide
440 lbs. (200kg)	440 lbs. (200kg)	440 lbs. (200kg)	440 lbs. (200kg)
EW	HW	MW	DW
EWDR518-75 EWDR518-75 EWDR-LR207-75 EWDR-LR207-75 EWDR415-100 EWDR310-150 EWDR-LR207-200	HWDR628-75 HWDR628-75 HWDR-LR312-75 HWDR-LR312-75 HWDR524-100 HWDR312-150 HWDR-LR106-200	MWDR732-75 MWDR732-75 MWDR-LR312-75 MWDR-LR312-75 MWDR628-100 MWDR420-150 MWDR-LR106-200	DWDR836-75 DWDR836-75 DWDR-LR415-75 DWDR-LR415-75 DWDR732-100 DWDR524-150 DWDR-LR106-200
EW0750-0701F- <input type="checkbox"/> <input type="checkbox"/> <input type="checkbox"/> EW0750-0701FA- <input type="checkbox"/> <input type="checkbox"/> <input type="checkbox"/>	HW0750-0701F- <input type="checkbox"/> <input type="checkbox"/> <input type="checkbox"/> HW0750-0701FA- <input type="checkbox"/> <input type="checkbox"/> <input type="checkbox"/>	MW0750-0701F- <input type="checkbox"/> <input type="checkbox"/> <input type="checkbox"/> MW0750-0701FA- <input type="checkbox"/> <input type="checkbox"/> <input type="checkbox"/>	DW0750-0701F- <input type="checkbox"/> <input type="checkbox"/> <input type="checkbox"/> DW0750-0701FA- <input type="checkbox"/> <input type="checkbox"/> <input type="checkbox"/>
EW	HW	MW	DW
EWDR518-75 EWDR518-75 EWDR415-100 EWDR415-100 EWDR415-100 EWDR310-150 EWDR310-150	HWDR524-75 HWDR524-75 HWDR420-100 HWDR420-100 HWDR420-100 HWDR312-150 HWDR312-150	MWDR-LR518-75 MWDR-LR518-75 MWDR-LR312-100 MWDR-LR312-100 MWDR-LR312-100 MWDR-LR209-150 MWDR-LR209-150	DWDR-LR415-75 DWDR-LR415-75 DWDR-LR312-100 DWDR-LR312-100 DWDR-LR312-100 DWDR-LR209-150 DWDR-LR209-150
EW0750-0703F- <input type="checkbox"/> <input type="checkbox"/> <input type="checkbox"/> EW0750-0703FA- <input type="checkbox"/> <input type="checkbox"/> <input type="checkbox"/>	HW0750-0703F- <input type="checkbox"/> <input type="checkbox"/> <input type="checkbox"/> HW0750-0703FA- <input type="checkbox"/> <input type="checkbox"/> <input type="checkbox"/>	MW0750-0703F- <input type="checkbox"/> <input type="checkbox"/> <input type="checkbox"/> MW0750-0703FA- <input type="checkbox"/> <input type="checkbox"/> <input type="checkbox"/>	DW0750-0703F- <input type="checkbox"/> <input type="checkbox"/> <input type="checkbox"/> DW0750-0703FA- <input type="checkbox"/> <input type="checkbox"/> <input type="checkbox"/>
EW	HW	MW	DW
ESDR020-100 EWDR518-100 EWDR518-100 EWDR415-100 EWDR415-100 EWDR310-100 EWDR310-150	HWDR628-100 HWDR628-100 HWDR420-100 HWDR420-100 HWDR-LR312-100 HWDR-LR312-100 HWDR209-150	MWDR-LR518-100 MWDR-LR518-100 MWDR-LR518-100 MWDR-LR312-100 MWDR-LR312-100 MWDR-LR312-100 MWDR203-150	DWDR-LR518-100 DWDR-LR518-100 DWDR-LR518-100 DWDR-LR312-100 DWDR-LR312-100 DWDR-LR312-100 DWDR203-150
EW0750-0704F- <input type="checkbox"/> <input type="checkbox"/> <input type="checkbox"/> EW0750-0704FA- <input type="checkbox"/> <input type="checkbox"/> <input type="checkbox"/>	HW0750-0704F- <input type="checkbox"/> <input type="checkbox"/> <input type="checkbox"/> HW0750-0704FA- <input type="checkbox"/> <input type="checkbox"/> <input type="checkbox"/>	MW0750-0704F- <input type="checkbox"/> <input type="checkbox"/> <input type="checkbox"/> MW0750-0704FA- <input type="checkbox"/> <input type="checkbox"/> <input type="checkbox"/>	DW0750-0704F- <input type="checkbox"/> <input type="checkbox"/> <input type="checkbox"/> DW0750-0704FA- <input type="checkbox"/> <input type="checkbox"/> <input type="checkbox"/>
EW	HW	MW	DW
EWDR040-75 EWDR-LR312-75 EWDR-LR312-75 EWDR-LR207-75 EWDR310-100 EWDR310-100 EWDR207-100 EWDR207-150	HWDR628-75 HWDR628-75 HWDR524-75 HWDR524-75 HWDR420-100 HWDR420-100 HWDR420-100 HWDR209-150	MWDR-LR518-75 MWDR-LR518-75 MWDR628-75 MWDR628-75 MWDR524-100 MWDR524-100 MWDR524-100 MWDR-LR209-150	DWDR-LR518-75 DWDR-LR518-75 DWDR-LR415-75 DWDR-LR415-75 DWDR-LR312-100 DWDR-LR312-100 DWDR-LR312-100 DWDR-LR209-150
EW0750-0801F- <input type="checkbox"/> <input type="checkbox"/> <input type="checkbox"/> EW0750-0801FA- <input type="checkbox"/> <input type="checkbox"/> <input type="checkbox"/>	HW0750-0801F- <input type="checkbox"/> <input type="checkbox"/> <input type="checkbox"/> HW0750-0801FA- <input type="checkbox"/> <input type="checkbox"/> <input type="checkbox"/>	MW0750-0801F- <input type="checkbox"/> <input type="checkbox"/> <input type="checkbox"/> MW0750-0801FA- <input type="checkbox"/> <input type="checkbox"/> <input type="checkbox"/>	DW0750-0801F- <input type="checkbox"/> <input type="checkbox"/> <input type="checkbox"/> DW0750-0801FA- <input type="checkbox"/> <input type="checkbox"/> <input type="checkbox"/>

MODEL 900 FULL DEPTH CABINET COMBINATIONS (28.5" DEEP X 39.375" HEIGHT)

■ Select: Base ■ Select: Lock □ Select: Color

See page 40 for details.

	Cabinet Width	NW-16.85" Wide	MP-22.20" Wide	SC-28.23" Wide
 0900-0501	Drawer Capacities	165 lbs. (75kg)	440 lbs. (200kg)	440 lbs. (200kg)
	Drawers Usable Ht. (Points)	NW	MP	SC
	5" 5.12" (150)	NWDR107-150	MPDR209-150	DR316-150
	5" 5.12" (150)	NWDR107-150	MPDR104-150	DR316-150
7" 5.12" (150)	NWDR104-150	MPDR104-150	DR316-150	
9" 7.09" (200)	NWDR104-200	MPDR104-200	DR209-200	
9" 9.06" (250)	NWDR104-250	MPDR104-250	DR104-250	
Cabinets				
Without interiors	NW0900-0501N- <input type="checkbox"/> <input type="checkbox"/> <input type="checkbox"/>	MP0900-0501F- <input type="checkbox"/> <input type="checkbox"/> <input type="checkbox"/>	SC0900-0501F- <input type="checkbox"/> <input type="checkbox"/> <input type="checkbox"/>	
With Interiors	NW0900-0501NA- <input type="checkbox"/> <input type="checkbox"/> <input type="checkbox"/>	MP0900-0501FA- <input type="checkbox"/> <input type="checkbox"/> <input type="checkbox"/>	SC0900-0501FA- <input type="checkbox"/> <input type="checkbox"/> <input type="checkbox"/>	
 0900-0503	Drawers Usable Ht. (Points)	NW	MP	SC
	3" 3.15" (100)	NWDR212-100	MPDR312-100	DR420-100
	5" 5.12" (150)	NWDR209-150	MPDR312-150	DR420-150
	7" 7.09" (200)	NWDR108-200	MPDR209-200	DR316-200
7" 7.09" (200)	NWDR108-200	MPDR209-200	DR316-200	
9" 9.06" (250)	NWDR104-250	MPDR104-250	DR106-250	
Cabinets				
Without interiors	NW0900-0503N- <input type="checkbox"/> <input type="checkbox"/> <input type="checkbox"/>	MP0900-0503F- <input type="checkbox"/> <input type="checkbox"/> <input type="checkbox"/>	SC0900-0503F- <input type="checkbox"/> <input type="checkbox"/> <input type="checkbox"/>	
With Interiors	NW0900-0503NA- <input type="checkbox"/> <input type="checkbox"/> <input type="checkbox"/>	MP0900-0503FA- <input type="checkbox"/> <input type="checkbox"/> <input type="checkbox"/>	SC0900-0503FA- <input type="checkbox"/> <input type="checkbox"/> <input type="checkbox"/>	
 0900-0605	Drawers Usable Ht. (Points)	NW	MP	SC
	5" 5.12" (150)	NWDR106-150	MPDR104-150	DR316-150
	5" 5.12" (150)	NWDR106-150	MPDR104-150	DR316-150
	5" 5.12" (150)	NWDR209-150	MPDR206-150	DR209-150
5" 5.12" (150)	NWDR209-150	MPDR206-150	DR209-150	
5" 5.12" (150)	NWDR212-150	MPDR209-150	DR104-150	
5" 5.12" (150)	NWDR212-150	MPDR209-150	DR104-150	
Cabinets				
Without interiors	NW0900-0605N- <input type="checkbox"/> <input type="checkbox"/> <input type="checkbox"/>	MP0900-0605F- <input type="checkbox"/> <input type="checkbox"/> <input type="checkbox"/>	SC0900-0605F- <input type="checkbox"/> <input type="checkbox"/> <input type="checkbox"/>	
With Interiors	NW0900-0605NA- <input type="checkbox"/> <input type="checkbox"/> <input type="checkbox"/>	MP0900-0605FA- <input type="checkbox"/> <input type="checkbox"/> <input type="checkbox"/>	SC0900-0605FA- <input type="checkbox"/> <input type="checkbox"/> <input type="checkbox"/>	
 0900-0702	Drawers Usable Ht. (Points)	NW	MP	SC
	3" 3.15" (100)	NWDR108-100	MPDR206-100	DR209-100
	3" 3.15" (100)	NWDR108-100	MPDR206-100	DR209-100
	3" 3.15" (100)	NWDR106-100	MPDR316-100	DR420-100
3" 3.15" (100)	NWDR106-100	MPDR316-100	DR420-100	
5" 5.12" (150)	NWDR209-150	MPDR209-150	DR316-150	
5" 5.12" (150)	NWDR209-150	MPDR209-150	DR316-150	
7" 7.09" (200)	NWDR105-200	MPDR104-200	DR104-200	
Cabinets				
Without interiors	NW0900-0702N- <input type="checkbox"/> <input type="checkbox"/> <input type="checkbox"/>	MP0900-0702F- <input type="checkbox"/> <input type="checkbox"/> <input type="checkbox"/>	SC0900-0702F- <input type="checkbox"/> <input type="checkbox"/> <input type="checkbox"/>	
With Interiors	NW0900-0702NA- <input type="checkbox"/> <input type="checkbox"/> <input type="checkbox"/>	MP0900-0702FA- <input type="checkbox"/> <input type="checkbox"/> <input type="checkbox"/>	SC0900-0702FA- <input type="checkbox"/> <input type="checkbox"/> <input type="checkbox"/>	

See pages 66-75 for drawer layout detail.



CABINETS

EW-34.25" Wide	HW-40.28" Wide	MW-46.97" Wide	DW-56.34" Wide
440 lbs. (200kg)	440 lbs. (200kg)	440 lbs. (200kg)	440 lbs. (200kg)
EW	HW	MW	DW
EWDR310-150 EWDR310-150 EWDR310-150 EWDR207-200 EWM DL	HWDR312-150 HWDR209-150 HWDR209-150 HWDR209-200 HWM DL	MWDR-LR312-150 MWDR-LR209-150 MWDR-LR209-150 MWDR-LR209-200 MWDR203-250	DWDR-LR312-150 DWDR-LR209-150 DWDR-LR209-150 DWDR-LR209-200 DWDR203-250
EW0900-0501F- <input type="checkbox"/> <input type="checkbox"/> <input type="checkbox"/> EW0900-0501FA- <input type="checkbox"/> <input type="checkbox"/> <input type="checkbox"/>	HW0900-0501F- <input type="checkbox"/> <input type="checkbox"/> <input type="checkbox"/> HW0900-0501FA- <input type="checkbox"/> <input type="checkbox"/> <input type="checkbox"/>	MW0900-0501F- <input type="checkbox"/> <input type="checkbox"/> <input type="checkbox"/> MW0900-0501FA- <input type="checkbox"/> <input type="checkbox"/> <input type="checkbox"/>	DW0900-0501F- <input type="checkbox"/> <input type="checkbox"/> <input type="checkbox"/> DW0900-0501FA- <input type="checkbox"/> <input type="checkbox"/> <input type="checkbox"/>
EW	HW	MW	DW
EWDR310-100 EWDR310-150 EWDR212-200 EWDR212-200 EWDR207-250	HWDR420-100 HWDR312-150 HWDR312-200 HWDR209-200 HWDR209-250	MWDR-LR312-100 MWDR-LR312-150 MWDR-LR209-200 MWDR-LR209-200 MWDR-LR106-250	DWDR-LR312-100 DWDR-LR312-150 DWDR-LR209-200 DWDR-LR209-200 DWDR-LR106-250
EW0900-0503F- <input type="checkbox"/> <input type="checkbox"/> <input type="checkbox"/> EW0900-0503FA- <input type="checkbox"/> <input type="checkbox"/> <input type="checkbox"/>	HW0900-0503F- <input type="checkbox"/> <input type="checkbox"/> <input type="checkbox"/> HW0900-0503FA- <input type="checkbox"/> <input type="checkbox"/> <input type="checkbox"/>	MW0900-0503F- <input type="checkbox"/> <input type="checkbox"/> <input type="checkbox"/> MW0900-0503FA- <input type="checkbox"/> <input type="checkbox"/> <input type="checkbox"/>	DW0900-0503F- <input type="checkbox"/> <input type="checkbox"/> <input type="checkbox"/> DW0900-0503FA- <input type="checkbox"/> <input type="checkbox"/> <input type="checkbox"/>
EW	HW	MW	DW
EWDR415-150 EWDR415-150 EWDR310-150 EWDR310-150 EWDR212-150 EWDR212-150	HWDR524-150 HWDR524-150 HWDR312-150 HWDR312-150 HWDR209-150 HWDR209-150	MWDR628-150 MWDR628-150 MWDR420-150 MWDR420-150 MWDR312-150 MWDR312-150	DWDR732-150 DWDR732-150 DWDR-LR415-150 DWDR-LR415-150 DWDR-LR312-150 DWDR-LR312-150
EW0900-0605F- <input type="checkbox"/> <input type="checkbox"/> <input type="checkbox"/> EW0900-0605FA- <input type="checkbox"/> <input type="checkbox"/> <input type="checkbox"/>	HW0900-0605F- <input type="checkbox"/> <input type="checkbox"/> <input type="checkbox"/> HW0900-0605FA- <input type="checkbox"/> <input type="checkbox"/> <input type="checkbox"/>	MW0900-0605F- <input type="checkbox"/> <input type="checkbox"/> <input type="checkbox"/> MW0900-0605FA- <input type="checkbox"/> <input type="checkbox"/> <input type="checkbox"/>	DW0900-0605F- <input type="checkbox"/> <input type="checkbox"/> <input type="checkbox"/> DW0900-0605FA- <input type="checkbox"/> <input type="checkbox"/> <input type="checkbox"/>
EW	HW	MW	DW
EWDR518-100 EWDR518-100 EWDR415-100 EWDR415-100 EWDR310-150 EWDR310-150 EWDR212-200	HWDR524-100 HWDR524-100 HWDR420-100 HWDR420-100 HWDR312-150 HWDR312-150 HWDR209-200	MWDR-LR415-100 MWDR-LR415-100 MWDR-LR312-100 MWDR-LR312-100 MWDR-LR209-150 MWDR-LR209-150 MWDR-LR106-200	DWDR-LR415-100 DWDR-LR415-100 DWDR-LR312-100 DWDR-LR312-100 DWDR-LR209-150 DWDR-LR209-150 DWDR-LR106-200
EW0900-0702F- <input type="checkbox"/> <input type="checkbox"/> <input type="checkbox"/> EW0900-0702FA- <input type="checkbox"/> <input type="checkbox"/> <input type="checkbox"/>	HW0900-0702F- <input type="checkbox"/> <input type="checkbox"/> <input type="checkbox"/> HW0900-0702FA- <input type="checkbox"/> <input type="checkbox"/> <input type="checkbox"/>	MW0900-0702F- <input type="checkbox"/> <input type="checkbox"/> <input type="checkbox"/> MW0900-0702FA- <input type="checkbox"/> <input type="checkbox"/> <input type="checkbox"/>	DW0900-0702F- <input type="checkbox"/> <input type="checkbox"/> <input type="checkbox"/> DW0900-0702FA- <input type="checkbox"/> <input type="checkbox"/> <input type="checkbox"/>

Model 900 Cabinet Combinations continued on next page.

MODEL 900 FULL DEPTH CABINET COMBINATIONS (28.5" DEEP X 39.375" HEIGHT)

■ Select: Base ■ Select: Lock □ Select: Color

See page 40 for details.

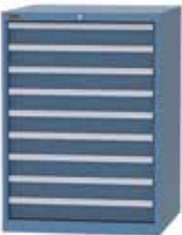
		Cabinet Width	NW-16.85" Wide	MP-22.20" Wide	SC-28.23" Wide
 <p>0900-0703</p>	Drawer Capacities		165 lbs. (75kg)	440 lbs. (200kg)	440 lbs. (200kg)
	Drawers Usable Ht. (Points)		NW	MP	SC
	2"	2.17" (75)	NWDR016-75	MPDR430-75	DR420-75
	2"	2.17" (75)	NWDR018-75	MPDR430-75	DR420-75
	3"	3.15" (100)	NWDR212-100	MPDR430-100	DR420-100
	3"	3.15" (100)	NWDR105-100	MPDR430-100	DR420-100
	5"	5.12" (150)	NWDR104-150	MPDR312-150	DR316-150
	7"	7.09" (200)	NWDR104-200	MPDR206-200	DR209-200
	7"	7.09" (200)	NWDR104-200	MPDR206-200	DR209-200
	Cabinets				
Without interiors		NW0900-0703N- <input type="checkbox"/>	MP0900-0703F- <input type="checkbox"/>	SC0900-0703F- <input type="checkbox"/>	
With Interiors		NW0900-0703NA- <input type="checkbox"/>	MP0900-0703FA- <input type="checkbox"/>	SC0900-0703FA- <input type="checkbox"/>	
 <p>0900-0901</p>	Drawers Usable Ht. (Points)		NW	MP	SC
	2"	2.17" (75)	NWDR018-75	MPDR510-75	DR524-75
	2"	2.17" (75)	NWDR018-75	MPDR510-75	DR524-75
	2"	2.17" (75)	NWDR212-75	MPDR316-75	DR420-75
	2"	2.17" (75)	NWDR212-75	MPDR316-75	DR420-75
	3"	3.15" (100)	NWDR107-100	MPDR209-100	DR316-100
	3"	3.15" (100)	NWDR107-100	MPDR209-100	DR316-100
	3"	3.15" (100)	NWDR107-100	MPDR209-100	DR316-100
	5"	5.12" (150)	NWDR104-150	MPDR104-150	DR209-150
	5"	5.12" (150)	NWDR104-150	MPDR104-150	DR209-150
Cabinets					
Without interiors		NW0900-0901N- <input type="checkbox"/>	MP0900-0901F- <input type="checkbox"/>	SC0900-0901F- <input type="checkbox"/>	
With Interiors		NW0900-0901NA- <input type="checkbox"/>	MP0900-0901FA- <input type="checkbox"/>	SC0900-0901FA- <input type="checkbox"/>	
 <p>0900-0904</p>	Drawers Usable Ht. (Points)		NW	MP	SC
	3"	3.15" (100)	NWDR016-100	MPDR510-100	DR524-100
	3"	3.15" (100)	NWDR016-100	MPDR510-100	DR524-100
	3"	3.15" (100)	NWDR008-100	MPDR430-100	DR524-100
	3"	3.15" (100)	NWDR008-100	MPDR430-100	DR420-100
	3"	3.15" (100)	NWDR209-100	MPDR316-100	DR420-100
	3"	3.15" (100)	NWDR209-100	MPDR316-100	DR420-100
	3"	3.15" (100)	NWDR108-100	MPDR316-100	DR316-100
	3"	3.15" (100)	NWDR108-100	MPDR209-100	DR316-100
	3"	3.15" (100)	NWDR107-100	MPDR209-100	DR316-100
Cabinets					
Without interiors		NW0900-0904N- <input type="checkbox"/>	MP0900-0904F- <input type="checkbox"/>	SC0900-0904F- <input type="checkbox"/>	
With Interiors		NW0900-0904NA- <input type="checkbox"/>	MP0900-0904FA- <input type="checkbox"/>	SC0900-0904FA- <input type="checkbox"/>	
 <p>0900-1001</p>	Drawers Usable Ht. (Points)		NW	MP	SC
	2"	2.17" (75)	NWDR024-75	MPDR028-75	DR036-75
	2"	2.17" (75)	NWDR012-75	MPDR018-75	DR036-75
	2"	2.17" (75)	NWDR212-75	MPDR316-75	DR036-75
	2"	2.17" (75)	NWDR212-75	MPDR316-75	DR524-75
	2"	2.17" (75)	NWDR209-75	MPDR209-75	DR524-75
	2"	2.17" (75)	NWDR209-75	MPDR209-75	DR524-75
	3"	3.15" (100)	NWDR108-100	MPDR206-100	DR420-100
	3"	3.15" (100)	NWDR108-100	MPDR206-100	DR420-100
	4"	4.13" (125)	NWDR104-100	MPDR104-100	DR316-100
4"	4.13" (125)	NWDR104-100	MPDR104-100	DR316-100	
Cabinets					
Without interiors		NW0900-1001N- <input type="checkbox"/>	MP0900-1001F- <input type="checkbox"/>	SC0900-1001F- <input type="checkbox"/>	
With Interiors		NW0900-1001NA- <input type="checkbox"/>	MP0900-1001FA- <input type="checkbox"/>	SC0900-1001FA- <input type="checkbox"/>	

See pages 66-75 for drawer layout detail.

EW-34.25" Wide	HW-40.28" Wide	MW-46.97" Wide	DW-56.34" Wide
440 lbs. (200kg)	440 lbs. (200kg)	440 lbs. (200kg)	440 lbs. (200kg)
EW	HW	MW	DW
EWDR518-75 EWDR518-75 EWDR415-100 EWDR415-100 EWDR310-150 EWDR212-200 EWDR212-200	HWDR036-75 HWDR024-75 HWDR628-100 HWDR-LR312-100 HWDR312-150 HWDR209-200 HWDR209-200	MWDR732-75 MWDR732-75 MWDR628-100 MWDR628-100 MWDR-LR312-150 MWDR-LR209-200 MWDR-LR209-200	DWDR836-75 DWDR836-75 DWDR732-100 DWDR732-100 DWDR-LR415-150 DWDR-LR312-200 DWDR-LR312-200
EW0900-0703F- <input type="checkbox"/> <input type="checkbox"/> <input type="checkbox"/> EW0900-0703FA- <input type="checkbox"/> <input type="checkbox"/> <input type="checkbox"/>	HW0900-0703F- <input type="checkbox"/> <input type="checkbox"/> <input type="checkbox"/> HW0900-0703FA- <input type="checkbox"/> <input type="checkbox"/> <input type="checkbox"/>	MW0900-0703F- <input type="checkbox"/> <input type="checkbox"/> <input type="checkbox"/> MW0900-0703FA- <input type="checkbox"/> <input type="checkbox"/> <input type="checkbox"/>	DW0900-0703F- <input type="checkbox"/> <input type="checkbox"/> <input type="checkbox"/> DW0900-0703FA- <input type="checkbox"/> <input type="checkbox"/> <input type="checkbox"/>
EW	HW	MW	DW
EWDR518-75 EWDR518-75 EWDR415-75 EWDR415-75 EWDR415-100 EWDR310-100 EWDR310-100 EWDR-LR312-150 EWDR-LR312-150	HWDR524-75 HWDR524-75 HWDR420-75 HWDR420-75 HWDR420-100 HWDR312-100 HWDR312-100 HWDR209-150 HWDR209-150	MWDR-LR415-75 MWDR-LR415-75 MWDR-LR415-75 MWDR-LR415-75 MWDR-LR312-100 MWDR-LR312-100 MWDR-LR312-100 MWDR-LR209-150 MWDR-LR209-150	DWDR-LR415-75 DWDR-LR415-75 DWDR-LR415-75 DWDR-LR415-75 DWDR-LR312-100 DWDR-LR312-100 DWDR-LR312-100 DWDR-LR209-150 DWDR-LR209-150
EW0900-0901F- <input type="checkbox"/> <input type="checkbox"/> <input type="checkbox"/> EW0900-0901FA- <input type="checkbox"/> <input type="checkbox"/> <input type="checkbox"/>	HW0900-0901F- <input type="checkbox"/> <input type="checkbox"/> <input type="checkbox"/> HW0900-0901FA- <input type="checkbox"/> <input type="checkbox"/> <input type="checkbox"/>	MW0900-0901F- <input type="checkbox"/> <input type="checkbox"/> <input type="checkbox"/> MW0900-0901FA- <input type="checkbox"/> <input type="checkbox"/> <input type="checkbox"/>	DW0900-0901F- <input type="checkbox"/> <input type="checkbox"/> <input type="checkbox"/> DW0900-0901FA- <input type="checkbox"/> <input type="checkbox"/> <input type="checkbox"/>
EW	HW	MW	DW
EWDR518-100 EWDR518-100 EWDR518-100 EWDR415-100 EWDR415-100 EWDR415-100 EWDR310-100 EWDR310-100 EWDR310-100	HWDR628-100 HWDR628-100 HWDR628-100 HWDR420-100 HWDR420-100 HWDR420-100 HWDR-LR209-100 HWDR-LR209-100 HWDR-LR209-100	MWDR-LR415-100 MWDR-LR415-100 MWDR-LR415-100 MWDR-LR312-100 MWDR-LR312-100 MWDR-LR312-100 MWDR-LR209-100 MWDR-LR209-100 MWDR-LR209-100	DWDR-LR312-100 DWDR-LR312-100 DWDR-LR312-100 DWDR-LR312-100 DWDR-LR209-100 DWDR-LR209-100 DWDR-LR209-100 DWDR-LR209-100 DWDR-LR209-100
EW0900-0904F- <input type="checkbox"/> <input type="checkbox"/> <input type="checkbox"/> EW0900-0904FA- <input type="checkbox"/> <input type="checkbox"/> <input type="checkbox"/>	HW0900-0904F- <input type="checkbox"/> <input type="checkbox"/> <input type="checkbox"/> HW0900-0904FA- <input type="checkbox"/> <input type="checkbox"/> <input type="checkbox"/>	MW0900-0904F- <input type="checkbox"/> <input type="checkbox"/> <input type="checkbox"/> MW0900-0904FA- <input type="checkbox"/> <input type="checkbox"/> <input type="checkbox"/>	DW0900-0904F- <input type="checkbox"/> <input type="checkbox"/> <input type="checkbox"/> DW0900-0904FA- <input type="checkbox"/> <input type="checkbox"/> <input type="checkbox"/>
EW	HW	MW	DW
EWDR040-75 EWDR020-75 EWDR518-75 EWDR518-75 EWDR415-75 EWDR415-75 EWDR310-100 EWDR310-100 EWDR212-100 EWDR212-100	HWDR628-75 HWDR036-75 HWDR524-75 HWDR524-75 HWDR420-75 HWDR420-75 HWDR-LR312-100 HWDR-LR312-100 HWDR209-100 HWDR209-100	MWDR628-75 MWDR628-75 MWDR524-75 MWDR524-75 MWDR420-75 MWDR420-75 MWDR-LR312-100 MWDR-LR312-100 MWDR-LR209-100 MWDR-LR209-100	DWDR732-75 DWDR732-75 DWDR621-75 DWDR621-75 DWDR-LR415-75 DWDR-LR415-75 DWDR-LR312-100 DWDR-LR312-100 DWDR-LR209-100 DWDR-LR209-100
EW0900-1001F- <input type="checkbox"/> <input type="checkbox"/> <input type="checkbox"/> EW0900-1001FA- <input type="checkbox"/> <input type="checkbox"/> <input type="checkbox"/>	HW0900-1001F- <input type="checkbox"/> <input type="checkbox"/> <input type="checkbox"/> HW0900-1001FA- <input type="checkbox"/> <input type="checkbox"/> <input type="checkbox"/>	MW0900-1001F- <input type="checkbox"/> <input type="checkbox"/> <input type="checkbox"/> MW0900-1001FA- <input type="checkbox"/> <input type="checkbox"/> <input type="checkbox"/>	DW0900-1001F- <input type="checkbox"/> <input type="checkbox"/> <input type="checkbox"/> DW0900-1001FA- <input type="checkbox"/> <input type="checkbox"/> <input type="checkbox"/>

MODEL 1200 FULL DEPTH CABINET COMBINATIONS (28.5" DEEP X 51.18" HEIGHT)

■ Select: Base ■ Select: Lock □ Select: Color

See page 40 for details.

	Cabinet Width	NW-16.85" Wide	MP-22.20" Wide	SC-28.23" Wide
 <p>3" 7" 7" 7" 9" 9"</p> <p>1200-0601</p>	Drawer Capacities	165 lbs. (75kg)	440 lbs. (200kg)	440 lbs. (200kg)
	Drawers Usable Ht. (Points) 3.15" (100) 7.09" (200) 7.09" (200) 7.09" (200) 9.06" (250) 9.06" (250)	NW NWDR107-100 NWDR106-200 NWDR106-200 NWDR108-200 NWDR104-250 NWDR104-250	MP MPDR316-100 MPDR316-200 MPDR316-200 MPDR316-200 MPDR206-250 MPDR206-250	SC DR420-100 DR420-200 DR420-200 DR420-200 DR316-250 DR316-250
	Cabinets Without interiors With Interiors	NW1200-0601N- <input type="checkbox"/> <input type="checkbox"/> <input type="checkbox"/> NW1200-0601NA- <input type="checkbox"/> <input type="checkbox"/> <input type="checkbox"/>	MP1200-0601F- <input type="checkbox"/> <input type="checkbox"/> <input type="checkbox"/> MP1200-0601FA- <input type="checkbox"/> <input type="checkbox"/> <input type="checkbox"/>	SC1200-0601F- <input type="checkbox"/> <input type="checkbox"/> <input type="checkbox"/> SC1200-0601FA- <input type="checkbox"/> <input type="checkbox"/> <input type="checkbox"/>
 <p>3" 3" 3" 5" 5" 7" 7" 7"</p> <p>1200-0801</p>	Drawers Usable Ht. (Points) 3.15" (100) 3.15" (100) 3.15" (100) 5.12" (150) 5.12" (150) 7.09" (200) 7.09" (200) 7.09" (200)	NW NWDR209-100 NWDR209-100 NWDR209-100 NWDR108-150 NWDR108-150 NWDR104-200 NWDR104-200 NWDR104-200	MP MPDR430-100 MPDR430-100 MPDR430-100 MPDR312-150 MPDR312-150 MPDR206-200 MPDR206-200 MPDR206-200	SC DR420-100 DR420-100 DR420-100 DR316-150 DR316-150 DR209-200 DR209-200 DR104-200
	Cabinets Without interiors With Interiors	NW1200-0801N- <input type="checkbox"/> <input type="checkbox"/> <input type="checkbox"/> NW1200-0801NA- <input type="checkbox"/> <input type="checkbox"/> <input type="checkbox"/>	MP1200-0801F- <input type="checkbox"/> <input type="checkbox"/> <input type="checkbox"/> MP1200-0801FA- <input type="checkbox"/> <input type="checkbox"/> <input type="checkbox"/>	SC1200-0801F- <input type="checkbox"/> <input type="checkbox"/> <input type="checkbox"/> SC1200-0801FA- <input type="checkbox"/> <input type="checkbox"/> <input type="checkbox"/>
 <p>2" 2" 2" 2" 3" 3" 5" 5" 7" 7"</p> <p>1200-1001</p>	Drawers Usable Ht. (Points) 2.17" (75) 2.17" (75) 2.17" (75) 2.17" (75) 3.15" (100) 3.15" (100) 5.12" (150) 5.12" (150) 7.09" (200) 7.09" (200)	NW NWDR209-75 NWDR209-75 NWDR209-75 NWDR209-75 NWDR209-100 NWDR209-100 NWDR108-150 NWDR108-150 NWDR106-200 NWDR106-200	MP MPDR312-75 MPDR312-75 MPDR312-75 MPDR312-75 MPDR312-100 MPDR312-100 MPDR206-150 MPDR206-150 MPDR206-200 MPDR206-200	SC DR036-75 DR036-75 DR524-75 DR524-75 DR420-100 DR420-100 DR312-150 DR312-150 DR209-200 DR209-200
	Cabinets Without interiors With Interiors	NW1200-1001N- <input type="checkbox"/> <input type="checkbox"/> <input type="checkbox"/> NW1200-1001NA- <input type="checkbox"/> <input type="checkbox"/> <input type="checkbox"/>	MP1200-1001F- <input type="checkbox"/> <input type="checkbox"/> <input type="checkbox"/> MP1200-1001FA- <input type="checkbox"/> <input type="checkbox"/> <input type="checkbox"/>	SC1200-1001F- <input type="checkbox"/> <input type="checkbox"/> <input type="checkbox"/> SC1200-1001FA- <input type="checkbox"/> <input type="checkbox"/> <input type="checkbox"/>
 <p>2" 2" 2" 2" 2" 3" 3" 3" 3" 3" 5"</p> <p>1200-1301</p>	Drawers Usable Ht. (Points) 2.17" (75) 2.17" (75) 2.17" (75) 2.17" (75) 2.17" (75) 2.17" (75) 3.15" (100) 3.15" (100) 3.15" (100) 3.15" (100) 3.15" (100) 3.15" (100) 3.15" (100) 5.12" (150)	NW NWDR106-75 NWDR106-75 NWDR106-75 NWDR107-75 NWDR107-75 NWDR107-75 NWDR106-100 NWDR106-100 NWDR106-100 NWDR106-100 NWDR107-100 NWDR107-100 NWDR107-100 NWDR106-150	MP MPDR209-75 MPDR209-75 MPDR209-75 MPDR209-75 MPDR209-75 MPDR209-75 MPDR206-100 MPDR206-100 MPDR206-100 MPDR206-100 MPDR206-100 MPDR206-100 MPDR206-100	SC DR524-75 DR524-75 DR524-75 DR524-75 DR524-75 DR524-75 DR316-75 DR316-100 DR316-100 DR316-100 DR316-100 DR316-100 DR316-100 DR209-150
	Cabinets Without interiors With Interiors	NW1200-1301N- <input type="checkbox"/> <input type="checkbox"/> <input type="checkbox"/> NW1200-1301NA- <input type="checkbox"/> <input type="checkbox"/> <input type="checkbox"/>	MP1200-1301F- <input type="checkbox"/> <input type="checkbox"/> <input type="checkbox"/> MP1200-1301FA- <input type="checkbox"/> <input type="checkbox"/> <input type="checkbox"/>	SC1200-1301F- <input type="checkbox"/> <input type="checkbox"/> <input type="checkbox"/> SC1200-1301FA- <input type="checkbox"/> <input type="checkbox"/> <input type="checkbox"/>

See pages 66-75 for drawer layout detail.





EW-34.25" Wide	HW-40.28" Wide	MW-46.97" Wide	DW-56.34" Wide
440 lbs. (200kg)	440 lbs. (200kg)	440 lbs. (200kg)	440 lbs. (200kg)
EW	HW	MW	DW
EWDR-LR312-100 EWDR-LR312-200 EWDR-LR312-200 EWDR-LR207-200 EWDR-LR207-250 EWDR-LR207-250	HWDR-LR312-100 HWDR-LR312-200 HWDR-LR209-200 HWDR-LR209-200 HWDR-LR209-250 HWDR-LR209-250	MWDR-LR312-100 MWDR-LR312-200 MWDR-LR209-200 MWDR-LR209-200 MWDR-LR209-250 MWDR-LR209-250	DWDR-LR312-100 DWDR-LR312-200 DWDR-LR209-200 DWDR-LR209-200 DWDR-LR209-250 DWDR-LR209-250
EW1200-0601F- <input type="checkbox"/> <input type="checkbox"/> <input type="checkbox"/> EW1200-0601FA- <input type="checkbox"/> <input type="checkbox"/> <input type="checkbox"/>	HW1200-0601F- <input type="checkbox"/> <input type="checkbox"/> <input type="checkbox"/> HW1200-0601FA- <input type="checkbox"/> <input type="checkbox"/> <input type="checkbox"/>	MW1200-0601F- <input type="checkbox"/> <input type="checkbox"/> <input type="checkbox"/> MW1200-0601FA- <input type="checkbox"/> <input type="checkbox"/> <input type="checkbox"/>	DW1200-0601F- <input type="checkbox"/> <input type="checkbox"/> <input type="checkbox"/> DW1200-0601FA- <input type="checkbox"/> <input type="checkbox"/> <input type="checkbox"/>
EW	HW	MW	DW
EWDR-LR312-100 EWDR-LR312-100 EWDR-LR312-100 EWDR-LR312-150 EWDR-LR207-150 EWDR-LR207-200 EWDR-LR207-200 EWDR207-200	HWDR-LR312-100 HWDR-LR312-100 HWDR-LR312-100 HWDR-LR312-150 HWDR-LR209-150 HWDR-LR209-200 HWDR-LR209-200 HWDR-LR209-200	MWDR-LR312-100 MWDR-LR312-100 MWDR-LR312-100 MWDR-LR312-150 MWDR-LR209-150 MWDR-LR209-200 MWDR-LR209-200 MWDR-LR209-200	DWDR-LR312-100 DWDR-LR312-100 DWDR-LR312-100 DWDR-LR312-150 DWDR-LR209-150 DWDR-LR209-200 DWDR-LR209-200 DWDR-LR209-200
EW1200-0801F- <input type="checkbox"/> <input type="checkbox"/> <input type="checkbox"/> EW1200-0801FA- <input type="checkbox"/> <input type="checkbox"/> <input type="checkbox"/>	HW1200-0801F- <input type="checkbox"/> <input type="checkbox"/> <input type="checkbox"/> HW1200-0801FA- <input type="checkbox"/> <input type="checkbox"/> <input type="checkbox"/>	MW1200-0801F- <input type="checkbox"/> <input type="checkbox"/> <input type="checkbox"/> MW1200-0801FA- <input type="checkbox"/> <input type="checkbox"/> <input type="checkbox"/>	DW1200-0801F- <input type="checkbox"/> <input type="checkbox"/> <input type="checkbox"/> DW1200-0801FA- <input type="checkbox"/> <input type="checkbox"/> <input type="checkbox"/>
EW	HW	MW	DW
EWDR518-75 EWDR518-75 EWDR518-75 EWDR-LR518-75 EWDR-LR518-100 EWDR-LR518-100 EWDR415-150 EWDR415-150 EWDR212-200 EWDR212-200	HWDR420-75 HWDR420-75 HWDR420-75 HWDR312-75 HWDR312-100 HWDR209-100 HWDR209-150 HWDR209-150 HWDR-LR209-200 HWDR-LR209-200	MWDR-LR415-75 MWDR-LR415-75 MWDR-LR415-75 MWDR-LR312-75 MWDR-LR312-100 MWDR-LR209-100 MWDR-LR209-150 MWDR-LR209-150 MWDR-LR209-200 MWDR-LR209-200	DWDR-LR415-75 DWDR-LR415-75 DWDR-LR415-75 DWDR-LR312-75 DWDR-LR312-100 DWDR-LR209-100 DWDR-LR209-150 DWDR-LR209-150 DWDR-LR209-200 DWDR-LR209-200
EW1200-1001F- <input type="checkbox"/> <input type="checkbox"/> <input type="checkbox"/> EW1200-1001FA- <input type="checkbox"/> <input type="checkbox"/> <input type="checkbox"/>	HW1200-1001F- <input type="checkbox"/> <input type="checkbox"/> <input type="checkbox"/> HW1200-1001FA- <input type="checkbox"/> <input type="checkbox"/> <input type="checkbox"/>	MW1200-1001F- <input type="checkbox"/> <input type="checkbox"/> <input type="checkbox"/> MW1200-1001FA- <input type="checkbox"/> <input type="checkbox"/> <input type="checkbox"/>	DW1200-1001F- <input type="checkbox"/> <input type="checkbox"/> <input type="checkbox"/> DW1200-1001FA- <input type="checkbox"/> <input type="checkbox"/> <input type="checkbox"/>
EW	HW	MW	DW
EWDR518-75 EWDR518-75 EWDR518-75 EWDR518-75 EWDR212-75 EWDR212-75 EWDR310-100 EWDR310-100 EWDR310-100 EWDR212-100 EWDR212-100 EWDR212-100 EWDR104-150	HWDR628-75 HWDR628-75 HWDR524-75 HWDR524-75 HWDR420-75 HWDR420-75 HWDR524-100 HWDR524-100 HWDR420-100 HWDR420-100 HWDR420-100 HWDR312-100 HWDR312-100 HWDR312-150	MWDR628-75 MWDR628-75 MWDR628-75 MWDR628-75 MWDR628-75 MWDR420-75 MWDR420-100 MWDR420-100 MWDR420-100 MWDR420-100 MWDR420-100 MWDR420-100 MWDR312-150	DWDR732-75 DWDR732-75 DWDR732-75 DWDR621-75 DWDR621-75 DWDR524-75 DWDR524-100 DWDR524-100 DWDR415-100 DWDR415-100 DWDR415-100 DWDR415-100 DWDR312-150
EW1200-1301F- <input type="checkbox"/> <input type="checkbox"/> <input type="checkbox"/> EW1200-1301FA- <input type="checkbox"/> <input type="checkbox"/> <input type="checkbox"/>	HW1200-1301F- <input type="checkbox"/> <input type="checkbox"/> <input type="checkbox"/> HW1200-1301FA- <input type="checkbox"/> <input type="checkbox"/> <input type="checkbox"/>	MW1200-1301F- <input type="checkbox"/> <input type="checkbox"/> <input type="checkbox"/> MW1200-1301FA- <input type="checkbox"/> <input type="checkbox"/> <input type="checkbox"/>	DW1200-1301F- <input type="checkbox"/> <input type="checkbox"/> <input type="checkbox"/> DW1200-1301FA- <input type="checkbox"/> <input type="checkbox"/> <input type="checkbox"/>

MODEL 1350 FULL DEPTH CABINET COMBINATIONS (28.5" DEEP X 57.125" HEIGHT)

■ Select: Base ■ Select: Lock □ Select: Color

See page 40 for details.

See pages 66–75 for drawer layout detail.

	Cabinet Width	NW-16.85" Wide	MP-22.20" Wide	SC-28.23" Wide
 1350-0608	Drawer Capacities	165 lbs. (75kg)	440 lbs. (200kg)	440 lbs. (200kg)
	Drawers Usable Ht. (Points)	NW	MP	SC
	5"	NWDR212-150	MPDR316-150	DR316-150
	7"	NWDR209-200	MPDR312-200	DR316-200
	9"	NWDR106-250	MPDR209-250	DR209-250
	9"	NWDR106-250	MPDR209-250	DR209-250
	9"	NWDR107-250	MPDR206-250	DR106-250
	9"	NWDR107-250	MPDR206-250	DR106-250
	Cabinets			
	Without interiors	NW1350-0608N- <input type="checkbox"/> <input type="checkbox"/> <input type="checkbox"/>	MP1350-0608F- <input type="checkbox"/> <input type="checkbox"/> <input type="checkbox"/>	SC1350-0608F- <input type="checkbox"/> <input type="checkbox"/> <input type="checkbox"/>
With Interiors	NW1350-0608NA- <input type="checkbox"/> <input type="checkbox"/> <input type="checkbox"/>	MP1350-0608FA- <input type="checkbox"/> <input type="checkbox"/> <input type="checkbox"/>	SC1350-0608FA- <input type="checkbox"/> <input type="checkbox"/> <input type="checkbox"/>	
 1350-0702	Drawers Usable Ht. (Points)	NW	MP	SC
	5"	NWDR107-150	MPDR104-150	DR104-150
	5"	NWDR107-150	MPDR104-150	DR104-150
	5"	NWDR209-150	MPDR104-150	DR104-150
	7"	NWDR209-200	MPDR206-200	DR209-200
	7"	NWDR107-200	MPDR206-200	DR209-200
	9"	NWDR106-250	MPDR104-250	DR316-250
	9"	NWDR106-250	MPDR104-250	DR316-250
	Cabinets			
	Without interiors	NW1350-0702N- <input type="checkbox"/> <input type="checkbox"/> <input type="checkbox"/>	MP1350-0702F- <input type="checkbox"/> <input type="checkbox"/> <input type="checkbox"/>	SC1350-0702F- <input type="checkbox"/> <input type="checkbox"/> <input type="checkbox"/>
With Interiors	NW1350-0702NA- <input type="checkbox"/> <input type="checkbox"/> <input type="checkbox"/>	MP1350-0702FA- <input type="checkbox"/> <input type="checkbox"/> <input type="checkbox"/>	SC1350-0702FA- <input type="checkbox"/> <input type="checkbox"/> <input type="checkbox"/>	
 1350-0801	Drawers Usable Ht. (Points)	NW	MP	SC
	5"	NWDR107-150	MPDR312-150	DR312-150
	5"	NWDR107-150	MPDR312-150	DR312-150
	5"	NWDR209-150	MPDR312-150	DR312-150
	5"	NWDR209-150	MPDR312-150	DR209-150
	5"	NWDR106-150	MPDR312-150	DR209-150
	7"	NWDR106-200	MPDR312-200	DR209-200
	7"	NWDR106-200	MPDR312-200	DR209-200
	7"	NWDR107-200	MPDR312-200	DR209-200
	Cabinets			
Without interiors	NW1350-0801N- <input type="checkbox"/> <input type="checkbox"/> <input type="checkbox"/>	MP1350-0801F- <input type="checkbox"/> <input type="checkbox"/> <input type="checkbox"/>	SC1350-0801F- <input type="checkbox"/> <input type="checkbox"/> <input type="checkbox"/>	
With Interiors	NW1350-0801NA- <input type="checkbox"/> <input type="checkbox"/> <input type="checkbox"/>	MP1350-0801FA- <input type="checkbox"/> <input type="checkbox"/> <input type="checkbox"/>	SC1350-0801FA- <input type="checkbox"/> <input type="checkbox"/> <input type="checkbox"/>	
 1350-0803	Drawers Usable Ht. (Points)	NW	MP	SC
	5"	NWDR106-150	MPDR206-150	DR312-150
	5"	NWDR106-150	MPDR206-150	DR312-150
	5"	NWDR107-150	MPDR206-150	DR312-150
	5"	NWDR107-150	MPDR209-150	DR312-150
	5"	NWDR209-150	MPDR209-150	DR312-150
	7"	NWDR106-200	MPDR104-200	DR206-200
	9"	NWDR104-250	MPDR104-250	DR206-250
	Cabinets			
	Without interiors	NW1350-0803N- <input type="checkbox"/> <input type="checkbox"/> <input type="checkbox"/>	MP1350-0803F- <input type="checkbox"/> <input type="checkbox"/> <input type="checkbox"/>	SC1350-0803F- <input type="checkbox"/> <input type="checkbox"/> <input type="checkbox"/>
With Interiors	NW1350-0803NA- <input type="checkbox"/> <input type="checkbox"/> <input type="checkbox"/>	MP1350-0803FA- <input type="checkbox"/> <input type="checkbox"/> <input type="checkbox"/>	SC1350-0803FA- <input type="checkbox"/> <input type="checkbox"/> <input type="checkbox"/>	



EW-34.25" Wide	HW-40.28" Wide	MW-46.97" Wide	DW-56.34" Wide
440 lbs. (200kg)	440 lbs. (200kg)	440 lbs. (200kg)	440 lbs. (200kg)
EW	HW	MW	DW
EWDR518-150 EWDR518-200 EWDR212-250 EWDR212-250 EWDR207-250 EWDR207-250	HWDR524-150 HWDR524-200 HWDR420-250 HWDR420-250 HWDR312-250 HWDR312-250	MWDR524-150 MWDR420-200 MWDR312-250 MWDR312-250 MWDR312-250 MWDR-LR209-250	DWDR621-150 DWDR524-200 DWDR415-250 DWDR415-250 DWDR415-250 DWDR-LR209-250
EW1350-0608F- <input type="checkbox"/> <input type="checkbox"/> <input type="checkbox"/> EW1350-0608FA- <input type="checkbox"/> <input type="checkbox"/> <input type="checkbox"/>	HW1350-0608F- <input type="checkbox"/> <input type="checkbox"/> <input type="checkbox"/> HW1350-0608FA- <input type="checkbox"/> <input type="checkbox"/> <input type="checkbox"/>	MW1350-0608F- <input type="checkbox"/> <input type="checkbox"/> <input type="checkbox"/> MW1350-0608FA- <input type="checkbox"/> <input type="checkbox"/> <input type="checkbox"/>	DW1350-0608F- <input type="checkbox"/> <input type="checkbox"/> <input type="checkbox"/> DW1350-0608FA- <input type="checkbox"/> <input type="checkbox"/> <input type="checkbox"/>
EW	HW	MW	DW
EWDR415-150 EWDR415-150 EWDR415-150 EWDR415-200 EWDR212-200 EWDR212-250 EWDR212-250	HWDR312-150 HWDR312-150 HWDR312-150 HWDR312-200 HWDR209-200 HWDR209-250 HWDR209-250	MWDR-LR312-150 MWDR-LR312-150 MWDR-LR312-150 MWDR-LR312-200 MWDR-LR209-200 MWDR-LR209-250 MWDR-LR106-250	DWDR-LR312-150 DWDR-LR312-150 DWDR-LR312-150 DWDR-LR312-200 DWDR-LR209-200 DWDR-LR209-250 DWDR-LR106-250
EW1350-0702F- <input type="checkbox"/> <input type="checkbox"/> <input type="checkbox"/> EW1350-0702FA- <input type="checkbox"/> <input type="checkbox"/> <input type="checkbox"/>	HW1350-0702F- <input type="checkbox"/> <input type="checkbox"/> <input type="checkbox"/> HW1350-0702FA- <input type="checkbox"/> <input type="checkbox"/> <input type="checkbox"/>	MW1350-0702F- <input type="checkbox"/> <input type="checkbox"/> <input type="checkbox"/> MW1350-0702FA- <input type="checkbox"/> <input type="checkbox"/> <input type="checkbox"/>	DW1350-0702F- <input type="checkbox"/> <input type="checkbox"/> <input type="checkbox"/> DW1350-0702FA- <input type="checkbox"/> <input type="checkbox"/> <input type="checkbox"/>
EW	HW	MW	DW
EWDR415-150 EWDR415-150 EWDR212-150 EWDR212-150 EWDR207-200 EWDR207-200 EWDR-LR207-200	HWDR420-150 HWDR420-150 HWDR420-150 HWDR312-150 HWDR312-150 HWDR209-200 HWDR209-200 HWDR209-200	MWDR-LR106-150 MWDR-LR106-150 MWDR-LR312-150 MWDR-LR312-150 MWDR-LR312-150 MWDR-LR209-200 MWDR-LR209-200 MWDR-LR209-200	DWDR-LR106-150 DWDR-LR106-150 DWDR-LR312-150 DWDR-LR312-150 DWDR-LR209-200 DWDR-LR209-200 DWDR-LR209-200 DWDR-LR209-200
EW1350-0801F- <input type="checkbox"/> <input type="checkbox"/> <input type="checkbox"/> EW1350-0801FA- <input type="checkbox"/> <input type="checkbox"/> <input type="checkbox"/>	HW1350-0801F- <input type="checkbox"/> <input type="checkbox"/> <input type="checkbox"/> HW1350-0801FA- <input type="checkbox"/> <input type="checkbox"/> <input type="checkbox"/>	MW1350-0801F- <input type="checkbox"/> <input type="checkbox"/> <input type="checkbox"/> MW1350-0801FA- <input type="checkbox"/> <input type="checkbox"/> <input type="checkbox"/>	DW1350-0801F- <input type="checkbox"/> <input type="checkbox"/> <input type="checkbox"/> DW1350-0801FA- <input type="checkbox"/> <input type="checkbox"/> <input type="checkbox"/>
EW	HW	MW	DW
EWDR415-150 EWDR415-150 EWDR415-150 EWDR415-150 EWDR415-150 EWDR415-150 EWDR212-200 EWDR212-250	HWDR420-150 HWDR420-150 HWDR420-150 HWDR524-150 HWDR524-150 HWDR524-150 HWDR312-200 HWDR209-250	MWDR-LR312-150 MWDR-LR312-150 MWDR-LR312-150 MWDR-LR209-150 MWDR-LR209-150 MWDR-LR106-150 MWDR-LR106-200 MWDR203-250	DWDR-LR312-150 DWDR-LR312-150 DWDR-LR312-150 DWDR-LR209-150 DWDR-LR209-150 DWDR-LR106-150 DWDR-LR106-200 DWDR203-250
EW1350-0803F- <input type="checkbox"/> <input type="checkbox"/> <input type="checkbox"/> EW1350-0803FA- <input type="checkbox"/> <input type="checkbox"/> <input type="checkbox"/>	HW1350-0803F- <input type="checkbox"/> <input type="checkbox"/> <input type="checkbox"/> HW1350-0803FA- <input type="checkbox"/> <input type="checkbox"/> <input type="checkbox"/>	MW1350-0803F- <input type="checkbox"/> <input type="checkbox"/> <input type="checkbox"/> MW1350-0803FA- <input type="checkbox"/> <input type="checkbox"/> <input type="checkbox"/>	DW1350-0803F- <input type="checkbox"/> <input type="checkbox"/> <input type="checkbox"/> DW1350-0803FA- <input type="checkbox"/> <input type="checkbox"/> <input type="checkbox"/>

MODEL 1350 FULL DEPTH CABINET COMBINATIONS (28.5" DEEP X 57.125" HEIGHT)

■ Select: Base ■ Select: Lock □ Select: Color

See page 40 for details.

See pages 66–75 for drawer layout detail.

	Cabinet Width	NW-16.85" Wide	MP-22.20" Wide	SC-28.23" Wide
 1350-0902	Drawer Capacities	165 lbs. (75kg)	440 lbs. (200kg)	440 lbs. (200kg)
	Drawers Usable Ht. (Points)	NW	MP	SC
	3" (100)	NWDR212-100	MPDR430-100	DR420-100
	3" (100)	NWDR209-100	MPDR430-100	DR420-100
	5" (100)	NWDR107-100	MPDR430-100	DR420-100
	5" (150)	NWDR212-150	MPDR316-150	DR316-150
	5" (150)	NWDR209-150	MPDR316-150	DR316-150
	7" (150)	NWDR107-150	MPDR316-150	DR316-150
	7" (200)	NWDR212-200	MPDR209-200	DR209-200
	7" (200)	NWDR209-200	MPDR209-200	DR209-200
	Cabinets			
Without interiors	NW1350-0902N- <input type="checkbox"/>	MP1350-0902F- <input type="checkbox"/>	SC1350-0902F- <input type="checkbox"/>	
With Interiors	NW1350-0902NA- <input type="checkbox"/>	MP1350-0902FA- <input type="checkbox"/>	SC1350-0902FA- <input type="checkbox"/>	
 1350-0903	Drawers Usable Ht. (Points)	NW	MP	SC
	5" (150)	NWDR209-150	MPDR312-150	DR316-150
	5" (150)	NWDR209-150	MPDR312-150	DR316-150
	5" (150)	NWDR209-150	MPDR312-150	DR316-150
	5" (150)	NWDR107-150	MPDR312-150	DR316-150
	5" (150)	NWDR107-150	MPDR209-150	DR212-150
	5" (150)	NWDR107-150	MPDR209-150	DR212-150
	5" (150)	NWDR106-150	MPDR209-150	DR212-150
	5" (150)	NWDR106-150	MPDR209-150	DR212-150
	5" (150)	NWDR106-150	MPDR209-150	DR212-150
	Cabinets			
Without interiors	NW1350-0903N- <input type="checkbox"/>	MP1350-0903F- <input type="checkbox"/>	SC1350-0903F- <input type="checkbox"/>	
With Interiors	NW1350-0903NA- <input type="checkbox"/>	MP1350-0903FA- <input type="checkbox"/>	SC1350-0903FA- <input type="checkbox"/>	
 1350-1002	Drawers Usable Ht. (Points)	NW	MP	SC
	2.17" (75)	NWDR104-75	MPDR524-75	DR524-75
	2.17" (75)	NWDR104-75	MPDR524-75	DR524-75
	3.15" (100)	NWDR106-100	MPDR430-100	DR420-100
	3.15" (100)	NWDR106-100	MPDR430-100	DR420-100
	3.15" (100)	NWDR106-100	MPDR430-100	DR420-100
	5.12" (150)	NWDR107-150	MPDR312-150	DR316-150
	5.12" (150)	NWDR107-150	MPDR312-150	DR316-150
	5.12" (150)	NWDR107-150	MPDR312-150	DR316-150
	9.06" (250)	NWDR104-250	MPDR206-250	DR104-250
	Cabinets			
Without interiors	NW1350-1002N- <input type="checkbox"/>	MP1350-1002F- <input type="checkbox"/>	SC1350-1002F- <input type="checkbox"/>	
With Interiors	NW1350-1002NA- <input type="checkbox"/>	MP1350-1002FA- <input type="checkbox"/>	SC1350-1002FA- <input type="checkbox"/>	
 1350-1103	Drawers Usable Ht. (Points)	NW	MP	SC
	2.17" (75)	NWDR106-75	MPDR316-75	DR320-75
	2.17" (75)	NWDR106-75	MPDR316-75	DR320-75
	2.17" (75)	NWDR106-75	MPDR316-75	DR320-75
	2.17" (75)	NWDR106-75	MPDR316-75	DR320-75
	4.13" (125)	NWDR107-100	MPDR312-100	DR316-100
	4.13" (125)	NWDR107-100	MPDR312-100	DR316-100
	4.13" (125)	NWDR107-100	MPDR312-100	DR316-100
	4.13" (125)	NWDR107-100	MPDR312-100	DR316-100
	5.12" (150)	NWDR108-150	MPDR209-150	DR312-150
	Cabinets			
Without interiors	NW1350-1103N- <input type="checkbox"/>	MP1350-1103F- <input type="checkbox"/>	SC1350-1103F- <input type="checkbox"/>	
With Interiors	NW1350-1103NA- <input type="checkbox"/>	MP1350-1103FA- <input type="checkbox"/>	SC1350-1103FA- <input type="checkbox"/>	

EW-34.25" Wide	HW-40.28" Wide	MW-46.97" Wide	DW-56.34" Wide
440 lbs. (200kg)	440 lbs. (200kg)	440 lbs. (200kg)	440 lbs. (200kg)
EW	HW	MW	DW
EWDR415-100 EWDR415-100 EWDR415-100 EWDR310-150 EWDR310-150 EWDR310-150 EWDR310-200 EWDR207-200 EWDR207-200	HWDR420-100 HWDR420-100 HWDR420-100 HWDR524-150 HWDR524-150 HWDR524-150 HWDR209-200 HWDR209-200 HWDR209-200	MWDR-LR415-100 MWDR-LR312-100 MWDR-LR312-100 MWDR-LR312-150 MWDR-LR209-150 MWDR-LR209-150 MWDR-LR209-200 MWDR-LR106-200 MWDR-LR106-200	DWDR-LR415-100 DWDR-LR312-100 DWDR-LR312-100 DWDR-LR312-150 DWDR-LR209-150 DWDR-LR209-150 DWDR-LR209-200 DWDR-LR106-200 DWDR-LR106-200
EW1350-0902F- <input type="checkbox"/> <input type="checkbox"/> <input type="checkbox"/> EW1350-0902FA- <input type="checkbox"/> <input type="checkbox"/> <input type="checkbox"/>	HW1350-0902F- <input type="checkbox"/> <input type="checkbox"/> <input type="checkbox"/> HW1350-0902FA- <input type="checkbox"/> <input type="checkbox"/> <input type="checkbox"/>	MW1350-0902F- <input type="checkbox"/> <input type="checkbox"/> <input type="checkbox"/> MW1350-0902FA- <input type="checkbox"/> <input type="checkbox"/> <input type="checkbox"/>	DW1350-0902F- <input type="checkbox"/> <input type="checkbox"/> <input type="checkbox"/> DW1350-0902FA- <input type="checkbox"/> <input type="checkbox"/> <input type="checkbox"/>
EW	HW	MW	DW
EWDR415-150 EWDR415-150 EWDR415-150 EWDR415-150 EWDR310-150 EWDR310-150 EWDR212-150 EWDR212-150 EWDR212-150	HWDR524-150 HWDR524-150 HWDR524-150 HWDR420-150 HWDR420-150 HWDR420-150 HWDR312-150 HWDR312-150 HWDR312-150	MWDR628-150 MWDR628-150 MWDR628-150 MWDR524-150 MWDR524-150 MWDR524-150 MWDR420-150 MWDR420-150 MWDR420-150	DWDR732-150 DWDR732-150 DWDR732-150 DWDR621-150 DWDR621-150 DWDR621-150 DWDR524-150 DWDR524-150 DWDR524-150
EW1350-0903F- <input type="checkbox"/> <input type="checkbox"/> <input type="checkbox"/> EW1350-0903FA- <input type="checkbox"/> <input type="checkbox"/> <input type="checkbox"/>	HW1350-0903F- <input type="checkbox"/> <input type="checkbox"/> <input type="checkbox"/> HW1350-0903FA- <input type="checkbox"/> <input type="checkbox"/> <input type="checkbox"/>	MW1350-0903F- <input type="checkbox"/> <input type="checkbox"/> <input type="checkbox"/> MW1350-0903FA- <input type="checkbox"/> <input type="checkbox"/> <input type="checkbox"/>	DW1350-0903F- <input type="checkbox"/> <input type="checkbox"/> <input type="checkbox"/> DW1350-0903FA- <input type="checkbox"/> <input type="checkbox"/> <input type="checkbox"/>
EW	HW	MW	DW
EWDR518-75 EWDR518-75 EWDR415-100 EWDR415-100 EWDR415-100 EWDR310-150 EWDR310-150 EWDR212-150 EWDR212-200 EWDR104-250	HWDR628-75 HWDR628-75 HWDR524-100 HWDR524-100 HWDR524-100 HWDR420-150 HWDR420-150 HWDR420-150 HWDR209-200 HWDR209-250	MWDR732-75 MWDR732-75 MWDR628-100 MWDR628-100 MWDR628-100 MWDR524-150 MWDR524-150 MWDR524-150 MWDR420-200 MWDR420-250	DWDR836-75 DWDR836-75 DWDR732-100 DWDR732-100 DWDR732-100 DWDR621-150 DWDR621-150 DWDR621-150 DWDR524-200 DWDR524-250
EW1350-1002F- <input type="checkbox"/> <input type="checkbox"/> <input type="checkbox"/> EW1350-1002FA- <input type="checkbox"/> <input type="checkbox"/> <input type="checkbox"/>	HW1350-1002F- <input type="checkbox"/> <input type="checkbox"/> <input type="checkbox"/> HW1350-1002FA- <input type="checkbox"/> <input type="checkbox"/> <input type="checkbox"/>	MW1350-1002F- <input type="checkbox"/> <input type="checkbox"/> <input type="checkbox"/> MW1350-1002FA- <input type="checkbox"/> <input type="checkbox"/> <input type="checkbox"/>	DW1350-1002F- <input type="checkbox"/> <input type="checkbox"/> <input type="checkbox"/> DW1350-1002FA- <input type="checkbox"/> <input type="checkbox"/> <input type="checkbox"/>
EW	HW	MW	DW
EWDR518-75 EWDR518-75 EWDR518-75 EWDR518-75 EWDR415-100 EWDR415-100 EWDR415-100 EWDR310-150 EWDR310-150 EWDR212-250	HWDR420-75 HWDR420-75 HWDR420-75 HWDR420-75 HWDR312-100 HWDR312-100 HWDR312-100 HWDR312-100 HWDR-LR209-150 HWDR-LR209-150 HWDR209-250	MWDR524-75 MWDR524-75 MWDR524-75 MWDR524-75 MWDR420-100 MWDR420-100 MWDR420-100 MWDR420-100 MWDR-LR209-150 MWDR-LR209-150 MWDR-LR209-250	DWDR621-75 DWDR621-75 DWDR621-75 DWDR621-75 DWDR524-100 DWDR524-100 DWDR524-100 DWDR524-100 DWDR-LR209-150 DWDR-LR209-150 DWDR-LR209-250
EW1350-1103F- <input type="checkbox"/> <input type="checkbox"/> <input type="checkbox"/> EW1350-1103FA- <input type="checkbox"/> <input type="checkbox"/> <input type="checkbox"/>	HW1350-1103F- <input type="checkbox"/> <input type="checkbox"/> <input type="checkbox"/> HW1350-1103FA- <input type="checkbox"/> <input type="checkbox"/> <input type="checkbox"/>	MW1350-1103F- <input type="checkbox"/> <input type="checkbox"/> <input type="checkbox"/> MW1350-1103FA- <input type="checkbox"/> <input type="checkbox"/> <input type="checkbox"/>	DW1350-1103F- <input type="checkbox"/> <input type="checkbox"/> <input type="checkbox"/> DW1350-1103FA- <input type="checkbox"/> <input type="checkbox"/> <input type="checkbox"/>

MODEL 1350 FULL DEPTH CABINET COMBINATIONS (28.5" DEEP X 57.125" HEIGHT)

■ Select: Base ■ Select: Lock □ Select: Color

See page 40 for details.

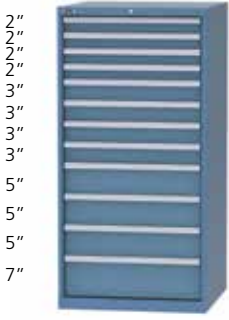

1350-1201

Cabinet Width	NW-16.85" Wide	MP-22.20" Wide	SC-28.23" Wide
Drawer Capacities	165 lbs. (75kg)	440 lbs. (200kg)	440 lbs. (200kg)
Drawers Usable Ht. (Points)	NW	MP	SC
2.17" (75)	NWDR107-75	MPDR206-75	DR312-75
2.17" (75)	NWDR107-75	MPDR206-75	DR312-75
2.17" (75)	NWDR107-75	MPDR206-75	DR312-75
3.15" (100)	NWDR107-100	MPDR206-100	DR312-100
3.15" (100)	NWDR107-100	MPDR206-100	DR312-100
3.15" (100)	NWDR209-100	MPDR312-100	DR420-100
3.15" (100)	NWDR209-100	MPDR312-100	DR420-100
5.12" (150)	NWDR106-150	MPDR312-150	DR420-150
5.12" (150)	NWDR106-150	MPDR104-150	DR209-150
5.12" (150)	NWDR106-150	MPDR104-150	DR209-150
7.09" (200)	NWDR106-200	MPDR104-200	DR209-200

Cabinets

Without interiors
With Interiors

NW1350-1201N-■□
NW1350-1201NA-■□

MP1350-1201F-■□
MP1350-1201FA-■□

SC1350-1201F-■□
SC1350-1201FA-■□

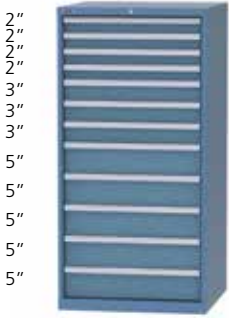

1350-1234

Cabinet Width	NW-16.85" Wide	MP-22.20" Wide	SC-28.23" Wide
Drawers Usable Ht. (Points)	NW	MP	SC
2.17" (75)	NWDR104-75	MPDR524-75	DR524-75
2.17" (75)	NWDR104-75	MPDR524-75	DR524-75
2.17" (75)	NWDR104-75	MPDR316-75	DR420-75
2.17" (75)	NWDR104-75	MPDR316-75	DR420-75
3.15" (100)	NWDR105-100	MPDR430-100	DR524-100
3.15" (100)	NWDR105-100	MPDR430-100	DR524-100
3.15" (100)	NWDR105-100	MPDR430-100	DR420-100
3.15" (100)	NWDR105-100	MPDR430-100	DR420-100
5.12" (150)	NWDR106-150	MPDR316-150	DR312-150
5.12" (150)	NWDR106-150	MPDR316-150	DR312-150
5.12" (150)	NWDR107-150	MPDR312-150	DR312-150
5.12" (150)	NWDR107-150	MPDR312-150	DR209-150
5.12" (150)	NWDR107-150	MPDR206-150	DR209-150

Cabinets

Without interiors
With Interiors

NW1350-1234N-■□
NW1350-1234NA-■□

MP1350-1234F-■□
MP1350-1234FA-■□

SC1350-1234F-■□
SC1350-1234FA-■□

See pages 66-75 for
drawer layout detail.

EW-34.25" Wide	HW-40.28" Wide	MW-46.97" Wide	DW-56.34" Wide
440 lbs. (200kg)	440 lbs. (200kg)	440 lbs. (200kg)	440 lbs. (200kg)
EW	HW	MW	DW
EWDR518-75 EWDR518-75 EWDR415-75 EWDR415-75 EWDR-LR312-100 EWDR-LR312-100 EWDR-LR312-100 EWDR-LR312-100 EWDR-LR207-150 EWDR-LR207-150 EWDR-LR207-150 EWDR-LR207-200	HWDR420-75 HWDR420-75 HWDR312-75 HWDR312-75 HWDR312-100 HWDR312-100 HWDR209-100 HWDR209-100 HWDR209-150 HWDR209-150 HWDR-LR106-150 HWDR-LR106-200	MWDR-LR415-75 MWDR-LR415-75 MWDR-LR415-75 MWDR-LR415-75 MWDR-LR312-100 MWDR-LR312-100 MWDR-LR312-100 MWDR-LR312-100 MWDR-LR209-150 MWDR-LR209-150 MWDR-LR106-150 MWDR-LR106-200	DWDR-LR415-75 DWDR-LR415-75 DWDR-LR415-75 DWDR-LR415-75 DWDR-LR312-100 DWDR-LR312-100 DWDR-LR312-100 DWDR-LR312-100 DWDR-LR209-150 DWDR-LR209-150 DWDR-LR106-150 DWDR-LR106-200
EW1350-1201F- <input type="checkbox"/> <input type="checkbox"/> <input type="checkbox"/> EW1350-1201FA- <input type="checkbox"/> <input type="checkbox"/> <input type="checkbox"/>	HW1350-1201F- <input type="checkbox"/> <input type="checkbox"/> <input type="checkbox"/> HW1350-1201FA- <input type="checkbox"/> <input type="checkbox"/> <input type="checkbox"/>	MW1350-1201F- <input type="checkbox"/> <input type="checkbox"/> <input type="checkbox"/> MW1350-1201FA- <input type="checkbox"/> <input type="checkbox"/> <input type="checkbox"/>	DW1350-1201F- <input type="checkbox"/> <input type="checkbox"/> <input type="checkbox"/> DW1350-1201FA- <input type="checkbox"/> <input type="checkbox"/> <input type="checkbox"/>
EW	HW	MW	DW
EWDR518-75 EWDR518-75 EWDR415-75 EWDR415-75 EWDR518-100 EWDR518-100 EWDR415-100 EWDR310-150 EWDR310-150 EWDR310-150 EWDR212-150 EWDR212-150	HWDR628-75 HWDR628-75 HWDR524-75 HWDR524-75 HWDR628-100 HWDR628-100 HWDR524-100 HWDR420-150 HWDR420-150 HWDR420-150 HWDR209-150 HWDR209-150	MWDR732-75 MWDR732-75 MWDR628-75 MWDR628-75 MWDR732-100 MWDR732-100 MWDR628-100 MWDR524-150 MWDR524-150 MWDR524-150 MWDR312-150 MWDR312-150	DWDR836-75 DWDR836-75 DWDR732-75 DWDR732-75 DWDR621-100 DWDR621-100 DWDR524-100 DWDR524-150 DWDR524-150 DWDR415-150 DWDR415-150 DWDR415-150
EW1350-1234F- <input type="checkbox"/> <input type="checkbox"/> <input type="checkbox"/> EW1350-1234FA- <input type="checkbox"/> <input type="checkbox"/> <input type="checkbox"/>	HW1350-1234F- <input type="checkbox"/> <input type="checkbox"/> <input type="checkbox"/> HW1350-1234FA- <input type="checkbox"/> <input type="checkbox"/> <input type="checkbox"/>	MW1350-1234F- <input type="checkbox"/> <input type="checkbox"/> <input type="checkbox"/> MW1350-1234FA- <input type="checkbox"/> <input type="checkbox"/> <input type="checkbox"/>	DW1350-1234F- <input type="checkbox"/> <input type="checkbox"/> <input type="checkbox"/> DW1350-1234FA- <input type="checkbox"/> <input type="checkbox"/> <input type="checkbox"/>

Model 1350 Cabinet Combinations
continued on next page.

MODEL 1350 FULL DEPTH CABINET COMBINATIONS (28.5" DEEP X 57.125" HEIGHT)

■ Select: Base ■ Select: Lock □ Select: Color

See page 40 for details.

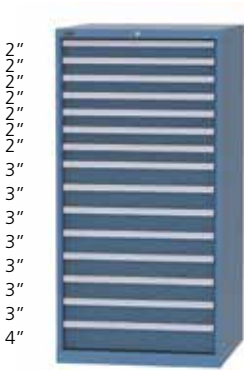

1350-1502

Cabinet Width	NW-16.85" Wide	MP-22.20" Wide	SC-28.23" Wide
Drawer Capacities	165 lbs. (75kg)	440 lbs. (200kg)	440 lbs. (200kg)
Drawers Usable Ht. (Points)	NW	MP	SC
2.17" (75)	NWDR104-75	MPDR312-75	DR320-75
2.17" (75)	NWDR104-75	MPDR312-75	DR320-75
2.17" (75)	NWDR104-75	MPDR312-75	DR320-75
2.17" (75)	NWDR104-75	MPDR312-75	DR320-75
2.17" (75)	NWDR105-75	MPDR209-75	DR320-75
2.17" (75)	NWDR105-75	MPDR209-75	DR320-75
2.17" (75)	NWDR105-75	MPDR209-75	DR320-75
3.15" (100)	NWDR008-100	MPDR312-100	DR320-100
3.15" (100)	NWDR008-100	MPDR312-100	DR320-100
3.15" (100)	NWDR108-100	MPDR312-100	DR320-100
3.15" (100)	NWDR108-100	MPDR312-100	DR320-100
3.15" (100)	NWDR212-100	MPDR209-100	DR320-100
3.15" (100)	NWDR212-100	MPDR209-100	DR320-100
3.15" (100)	NWDR107-100	MPDR209-100	DR320-100
4.13" (125)	NWDR107-100	MPDR209-100	DR320-100
Cabinets			
Without interiors	NW1350-1502N- <input type="checkbox"/> <input type="checkbox"/> <input type="checkbox"/>	MP1350-1502F- <input type="checkbox"/> <input type="checkbox"/> <input type="checkbox"/>	SC1350-1502F- <input type="checkbox"/> <input type="checkbox"/> <input type="checkbox"/>
With Interiors	NW1350-1502NA- <input type="checkbox"/> <input type="checkbox"/> <input type="checkbox"/>	MP1350-1502FA- <input type="checkbox"/> <input type="checkbox"/> <input type="checkbox"/>	SC1350-1502FA- <input type="checkbox"/> <input type="checkbox"/> <input type="checkbox"/>

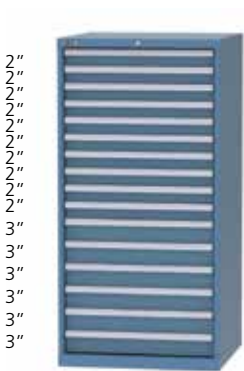

1350-1601

Drawers	NW	MP	SC
Usable Ht. (Points)			
2.17" (75)	NWDR106-75	MPDR024-75	DR036-75
2.17" (75)	NWDR106-75	MPDR024-75	DR036-75
2.17" (75)	NWDR106-75	MPDR012-75	DR524-75
2.17" (75)	NWDR106-75	MPDR012-75	DR524-75
2.17" (75)	NWDR106-75	MPDR430-75	DR524-75
2.17" (75)	NWDR107-75	MPDR430-75	DR524-75
2.17" (75)	NWDR107-75	MPDR430-75	DR524-75
2.17" (75)	NWDR107-75	MPDR316-75	DR524-75
2.17" (75)	NWDR107-75	MPDR316-75	DR420-75
2.17" (75)	NWDR107-75	MPDR316-75	DR420-75
3.15" (100)	NWDR107-100	MPDR312-100	DR420-100
3.15" (100)	NWDR107-100	MPDR312-100	DR420-100
3.15" (100)	NWDR107-100	MPDR209-100	DR312-100
3.15" (100)	NWDR104-100	MPDR209-100	DR312-100
3.15" (100)	NWDR104-100	MPDR206-100	DR312-100
3.15" (100)	NWDR104-100	MPDR206-100	DR312-100
Cabinets			
Without interiors	NW1350-1601N- <input type="checkbox"/> <input type="checkbox"/> <input type="checkbox"/>	MP1350-1601F- <input type="checkbox"/> <input type="checkbox"/> <input type="checkbox"/>	SC1350-1601F- <input type="checkbox"/> <input type="checkbox"/> <input type="checkbox"/>
With Interiors	NW1350-1601NA- <input type="checkbox"/> <input type="checkbox"/> <input type="checkbox"/>	MP1350-1601FA- <input type="checkbox"/> <input type="checkbox"/> <input type="checkbox"/>	SC1350-1601FA- <input type="checkbox"/> <input type="checkbox"/> <input type="checkbox"/>

See pages 66-75 for drawer layout detail.



CABINETS

EW-34.25" Wide	HW-40.28" Wide	MW-46.97" Wide	DW-56.34" Wide
440 lbs. (200kg)	440 lbs. (200kg)	440 lbs. (200kg)	440 lbs. (200kg)
EW	HW	MW	DW
EWDR-LR312-75 EWDR-LR312-75 EWDR-LR312-75 EWDR-LR312-75 EWDR-LR207-75 EWDR-LR207-75 EWDR-LR207-75 EWDR-LR312-100 EWDR-LR312-100 EWDR-LR312-100 EWDR-LR312-100 EWDR-LR207-100 EWDR-LR207-100 EWDR-LR207-100 EWDR-LR207-100	HWDR-LR312-75 HWDR-LR312-75 HWDR-LR209-75 HWDR-LR209-75 HWDR-LR209-75 HWDR-LR106-75 HWDR-LR106-75 HWDR-LR312-100 HWDR-LR312-100 HWDR-LR312-100 HWDR-LR209-100 HWDR-LR209-100 HWDR-LR209-100 HWDR-LR106-100 HWDR-LR106-100	MWDR-LR518-75 MWDR-LR518-75 MWDR-LR312-75 MWDR-LR312-75 MWDR-LR209-75 MWDR-LR209-75 MWDR-LR518-100 MWDR-LR518-100 MWDR-LR312-100 MWDR-LR312-100 MWDR-LR209-100 MWDR-LR209-100 MWDR-LR106-100 MWDR-LR106-100	DWDR-LR518-75 DWDR-LR518-75 DWDR-LR415-75 DWDR-LR415-75 DWDR-LR415-75 DWDR-LR312-75 DWDR-LR312-75 DWDR-LR518-100 DWDR-LR518-100 DWDR-LR415-100 DWDR-LR415-100 DWDR-LR312-100 DWDR-LR312-100 DWDR-LR209-100 DWDR-LR209-100
EW1350-1502F- <input type="checkbox"/> <input type="checkbox"/> <input type="checkbox"/> EW1350-1502FA- <input type="checkbox"/> <input type="checkbox"/> <input type="checkbox"/>	HW1350-1502F- <input type="checkbox"/> <input type="checkbox"/> <input type="checkbox"/> HW1350-1502FA- <input type="checkbox"/> <input type="checkbox"/> <input type="checkbox"/>	MW1350-1502F- <input type="checkbox"/> <input type="checkbox"/> <input type="checkbox"/> MW1350-1502FA- <input type="checkbox"/> <input type="checkbox"/> <input type="checkbox"/>	DW1350-1502F- <input type="checkbox"/> <input type="checkbox"/> <input type="checkbox"/> DW1350-1502FA- <input type="checkbox"/> <input type="checkbox"/> <input type="checkbox"/>
EW	HW	MW	DW
EWDR020-75 EWDR020-75 EWDR040-75 EWDR040-75 EWDR518-75 EWDR518-75 EWDR415-75 EWDR415-75 EWDR415-75 EWDR415-75 EWDR518-100 EWDR518-100 EWDR212-100 EWDR212-100 EWDR212-100 EWDR212-100	HWDR024-75 HWDR024-75 HWDR-LR312-75 HWDR628-75 HWDR628-75 HWDR524-75 HWDR524-75 HWDR524-75 HWDR420-75 HWDR420-75 HWDR420-100 HWDR312-100 HWDR312-100 HWDR312-100 HWDR-LR209-100 HWDR-LR209-100	MWDR836-75 MWDR836-75 MWDR732-75 MWDR732-75 MWDR628-75 MWDR628-75 MWDR524-75 MWDR524-75 MWDR420-75 MWDR420-75 MWDR312-100 MWDR312-100 MWDR-LR209-100 MWDR-LR209-100 MWDR-LR106-100 MWDR-LR106-100	DWDR732-75 DWDR732-75 DWDR621-75 DWDR621-75 DWDR524-75 DWDR524-75 DWDR415-75 DWDR415-75 DWDR-LR415-75 DWDR-LR415-75 DWDR-LR312-100 DWDR-LR312-100 DWDR-LR209-100 DWDR-LR209-100 DWDR-LR106-100 DWDR-LR106-100
EW1350-1601F- <input type="checkbox"/> <input type="checkbox"/> <input type="checkbox"/> EW1350-1601FA- <input type="checkbox"/> <input type="checkbox"/> <input type="checkbox"/>	HW1350-1601F- <input type="checkbox"/> <input type="checkbox"/> <input type="checkbox"/> HW1350-1601FA- <input type="checkbox"/> <input type="checkbox"/> <input type="checkbox"/>	MW1350-1601F- <input type="checkbox"/> <input type="checkbox"/> <input type="checkbox"/> MW1350-1601FA- <input type="checkbox"/> <input type="checkbox"/> <input type="checkbox"/>	DW1350-1601F- <input type="checkbox"/> <input type="checkbox"/> <input type="checkbox"/> DW1350-1601FA- <input type="checkbox"/> <input type="checkbox"/> <input type="checkbox"/>

How to order an NW Width Preconfigured Drawer Interior Set

To order the drawer interior sets shown on this page, use the part number in the chart and add the drawer height in place of the green box.

EXAMPLE: to order an NWDR106 drawer interior set for a 100 height (3") drawer, the part ordering number would be **NWDR106-100**.



For all drawer heights

PART NO.	COMPTS.	CMPT. WIDTH
NWDR104-█	2	5.50"
	2	6.25"



For drawer heights 75 through 200

PART NO.	COMPTS.	CMPT. WIDTH
NWDR105-█	3	4.125"
	2	7.50"



For drawer heights 75 through 300

PART NO.	COMPTS.	CMPT. WIDTH
NWDR106-█	3	6.25"
	3	5.50"



For all drawer heights

PART NO.	COMPTS.	CMPT. WIDTH
NWDR107-█	4	4.125"
	3	7.50"



For all drawer heights

PART NO.	COMPTS.	CMPT. WIDTH
NWDR108-█	4	5.50"
	4	6.25"



For drawer heights 75 through 200

PART NO.	COMPTS.	CMPT. WIDTH
NWDR209-█	6	3.50"
	3	4.125"



For drawer heights 75 through 200

PART NO.	COMPTS.	CMPT. WIDTH
NWDR212-█	4	4.125"
	8	3.50"



For drawer heights 75 through 100

PART NO.	COMPTS.	CMPT. SIZE
NWDR008-■	8	6" x 6"



For drawer heights 75 through 100

PART NO.	COMPTS.	CMPT. SIZE
NWDR012-■	8	3" x 6"
	4	6" x 6"



For drawer heights 75 through 100

PART NO.	COMPTS.	CMPT. SIZE
NWDR016-■	16	3" x 6"



For drawer height 75

PART NO.	COMPTS.	CMPT. SIZE
NWDR018-■	2	6" x 6"
	8	3" x 6"
	8	3" x 3"



For drawer height 75

PART NO.	COMPTS.	CMPT. SIZE
NWDR024-■	16	3" x 3"
	8	3" x 6"



For drawer height 75

PART NO.	COMPTS.	CMPT. SIZE
NWDR082	16	3" x 3"
	24	3" x 2"



For drawer height 75

PART NO.	COMPTS.	CMPT. SIZE
NWDR083	32	2" x 3"
	24	2" x 2"



Sliding accessory tray

PART NO.	COMPTS.	CMPT. WID.
NWDR-AT06	5	3"

How to order an MP Width Preconfigured Drawer Interior Set

To order the drawer interior sets shown on this page, use the part number in the chart and add the drawer height in place of the green box.

EXAMPLE: to order an MPDR206 drawer interior set for a 100 height (3") drawer, the part ordering number would be **MPDR206-100**.



Sliding accessory tray

For drawer heights 100 through 300

PART NO.	COMPTS.	CMPT. WIDTH
MPDR-AT10	1	6"
	8	3"



For all drawer heights		
PART NO.	COMPTS.	CMPT. WIDTH
MPDR104-■	2	7.50"
	2	9.125"



For all drawer heights		
PART NO.	COMPTS.	CMPT. WIDTH
MPDR108-■	4	7.55"
	4	9.56"



For all drawer heights		
PART NO.	COMPTS.	CMPT. WIDTH
MPDR206-■	6	5.50"



For all drawer heights		
PART NO.	COMPTS.	CMPT. WIDTH
MPDR209-■	9	5.50"



For drawer heights 75 through 150		
PART NO.	COMPTS.	CMPT. WIDTH
MPDR312-■	3	3.50"
	9	4.125"



For drawer heights 75 through 150		
PART NO.	COMPTS.	CMPT. WIDTH
MPDR316-■	4	3.50"
	12	4.125"



For drawer heights 75 through 125		
PART NO.	COMPTS.	CMPT. WIDTH
MPDR430-■	18	2.625"
	12	3.50"



For drawer heights 75 through 150		
PART NO.	COMPTS.	CMPT. DEPTH
MPDR510-■	6	3.50"
	4	15.625"



For drawer heights 75 through 125		
PART NO.	COMPTS.	CMPT. WIDTH
MPDR524-■	12	2.125"
	12	2.625"



For drawer heights 75 through 125		
PART NO.	COMPTS.	CMPT. SIZE
MPDR012-■	12	6" x 6"



For drawer heights 75 through 125		
PART NO.	COMPTS.	CMPT. SIZE
MPDR018-■	12	3" x 6"
	6	6" x 6"



For drawer heights 75 and 100		
PART NO.	COMPTS.	CMPT. SIZE
MPDR024-■	24	3" x 6"



For drawer height 75		
PART NO.	COMPTS.	CMPT. SIZE
MPDR028-■	16	3" x 3"
	8	3" x 6"
	4	6" x 6"



For drawer height 75		
PART NO.	COMPTS.	CMPT. WIDTH
MPDR480	24	1.25"
	16	1.75"



For drawer height 75		
PART NO.	COMPTS.	CMPT. WIDTH
MPDR482	23	1.75"
	14	2.75"

How to order an SC Width

Preconfigured Drawer Interior Set

To order the drawer interior sets shown on these two pages, use the part number in the chart and add the drawer height in place of the green box.

EXAMPLE: to order a DR312 drawer interior set for a 100 height (3") drawer, the part ordering number would be **DR312-100**.



For all drawer heights		
PART NO.	COMPTS.	CMPT. WIDTH
DR104-■	4	11.50"



For drawer heights 75 through 300		
PART NO.	COMPTS.	CMPT. WIDTH
DR106-■	6	11.50"



For all drawer heights		
PART NO.	COMPTS.	CMPT. WIDTH
DR206-■	6	7.50"



For all drawer heights		
PART NO.	COMPTS.	CMPT. WIDTH
DR209-■	9	7.50"



For all drawer heights		
PART NO.	COMPTS.	CMPT. WIDTH
DR211-■	11	7.50"



For all drawer heights		
PART NO.	COMPTS.	CMPT. WIDTH
DR212-■	12	7.50"



For all drawer heights		
PART NO.	COMPTS.	CMPT. WIDTH
DR3AD-■	4	5.50"
	3	7.50"
	2	9.50"



For all drawer heights		
PART NO.	COMPTS.	CMPT. WIDTH
DR312-■	12	5.50"



For all drawer heights		
PART NO.	COMPTS.	CMPT. WIDTH
DR316-■	16	5.50"



For all drawer heights		
PART NO.	COMPTS.	CMPT. WIDTH
DR319-■	19	5.50"



For all drawer heights		
PART NO.	COMPTS.	CMPT. WIDTH
DR320-■	20	5.50"

SC Width Preconfigured Drawer Interior Set (continued)



For drawer heights 75 through 200

PART NO.	COMPTS.	CMPT. WIDTH
DR4AD-■	15	3.50"
	11	5.50"



For all drawer heights

PART NO.	COMPTS.	CMPT. WIDTH
DR406-■	2	5.50"
	4	5.50" x 18"

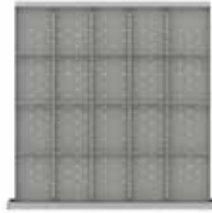

For drawer heights 75 through 200

PART NO.	COMPTS.	CMPT. WIDTH
DR420-■	16	4.125"
	4	4.875"



For drawer heights 75 through 200

PART NO.	COMPTS.	CMPT. WIDTH
DR425-■	20	4.125"
	5	4.125"



For drawer heights 75 through 200

PART NO.	COMPTS.	CMPT. WIDTH
DR518-■	18	3.50"



For drawer heights 75 through 200

PART NO.	COMPTS.	CMPT. WIDTH
DR524-■	24	3.50"



For drawer heights 75 through 200

PART NO.	COMPTS.	CMPT. WIDTH
DR530-■	30	3.50"



For drawer heights 75 through 200

PART NO.	COMPTS.	CMPT. WIDTH
DR548-■	48	3.50"



For drawer heights 75 through 200

PART NO.	COMPTS.	CMPT. WIDTH
DR635-■	30	2.625"
	5	3.50"



For drawer heights 75 through 150

PART NO.	COMPTS.	CMPT. WIDTH
DR712-■	6	3.50"
	6	3.50" x 16"



For drawer heights 75 and 100

PART NO.	COMPTS.	CMPT. WIDTH
DR740-■	20	2.125"
	20	2.625"



For drawer heights 75 and 100

PART NO.	COMPTS.	CMPT. WIDTH
DR818-■	18	2.125"



For drawer heights 75 and 100

PART NO.	COMPTS.	CMPT. SIZE
DR016-■	16	6" x 6"



For drawer heights 75 and 100

PART NO.	COMPTS.	CMPT. SIZE
DR024-■	16	3" x 6"
	8	6" x 6"



For drawer heights 75 and 100

PART NO.	COMPTS.	CMPT. SIZE
DR032-■	32	3" x 6"



For drawer height 75

PART NO.	COMPTS.	CMPT. SIZE
DR036-■	16	3" x 3"
	16	3" x 6"
	4	6" x 6"

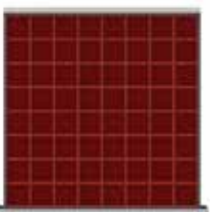

For drawer height 75

PART NO.	COMPTS.	CMPT. SIZE
DR064-■	64	3" x 3"



For drawer height 75

PART NO.	COMPTS.	CMPT. WIDTH
DR162	38	2.75"



For drawer height 75

PART NO.	COMPTS.	CMPT. WIDTH
DR163	51	1.75"



For drawer height 75

PART NO.	COMPTS.	CMPT. WIDTH
DR164	64	1.25"

How to order an EW Width Preconfigured Drawer Interior Set

To order the drawer interior sets shown on these two pages, use the part number in the chart and add the drawer height in place of the green box.

EXAMPLE: to order a EW312 drawer interior set for a 100 height (3") drawer, the part ordering number would be **EW312-100**.



For all drawer heights

PART NO.	COMPTS.	CMPT. WIDTH
EWDR-LR207-■	3	3.53"
	2	7.55"
	2	11.56"



For drawer heights 75 through 300

PART NO.	COMPTS.	CMPT. WIDTH
EWDR-LR312-■	4	3.53"
	6	5.54"
	2	7.55"

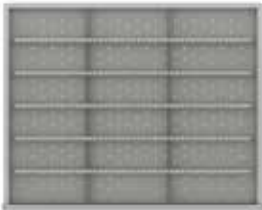

For all drawer heights

PART NO.	COMPTS.	CMPT. WIDTH
EWDR-LR518-■	18	3.53"

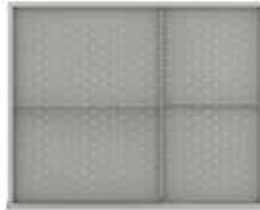

For all drawer heights

PART NO.	COMPTS.	CMPT. WIDTH
EWDR104-■	2	17.59"
	2	11.56"

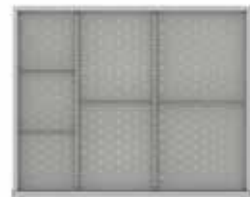

For all drawer heights

PART NO.	COMPTS.	CMPT. WIDTH
EWDR207-■	3	7.55"
	2	9.56"
	2	11.56"

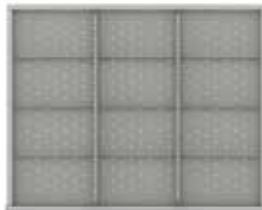

For all drawer heights

PART NO.	COMPTS.	CMPT. WIDTH
EWDR212-■	12	9.56"



For all drawer heights

PART NO.	COMPTS.	CMPT. WIDTH
EWDR310-■	3	3.53"
	3	5.54"
	2	7.55"
	2	11.56"

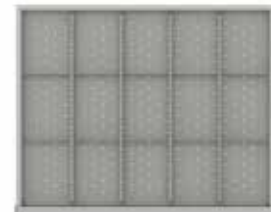

For all drawer heights

PART NO.	COMPTS.	CMPT. WIDTH
EWDR415-■	15	5.54"



For all drawer heights

PART NO.	COMPTS.	CMPT. WIDTH
EWDR518-■	9	4.20"
	9	4.87"

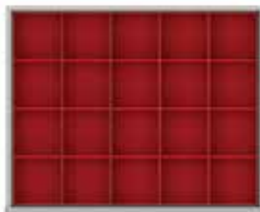

For drawer heights 75 through 125

PART NO.	COMPTS.	CMPT. WIDTH
EWDR020-■	20	6" x 6"

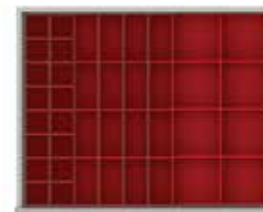

For drawer height 75

PART NO.	COMPTS.	CMPT. WIDTH
EWDR040-■	16	3" x 3"
	16	3" x 6"
	8	6" x 6"

How to order an HW Width Preconfigured Drawer Interior Set

To order the drawer interior sets shown on these two pages, use the part number in the chart and add the drawer height in place of the green box.

EXAMPLE: to order a HW312 drawer interior set for a 100 height (3") drawer, the part ordering number would be **HW312-100**.

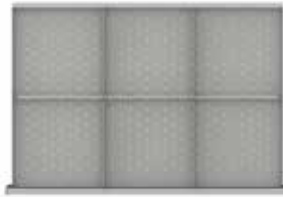

For drawer heights 75 through 200

PART NO.	COMPTS.	CMPT. WIDTH
HWDR-LR106-■	6	11.50"

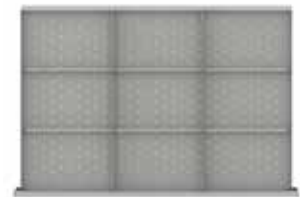

For drawer heights 75 through 300

PART NO.	COMPTS.	CMPT. WIDTH
HWDR-LR209-■	9	7.55"

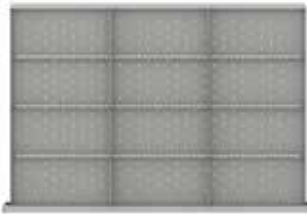

For all drawer heights

PART NO.	COMPTS.	CMPT. WIDTH
HWDR-LR312-■	12	5.50"

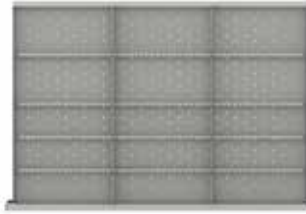

For drawer heights 75 through 200

PART NO.	COMPTS.	CMPT. WIDTH
HWDR-LR415-■	9	3.50"
	6	5.50"

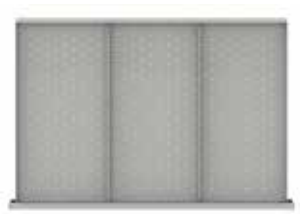

For all drawer heights

PART NO.	COMPTS.	CMPT. WIDTH
HWDR203-■	3	11.56"



For all drawer heights

PART NO.	COMPTS.	CMPT. WIDTH
HWDR209-■	9	11.56"



For all drawer heights

PART NO.	COMPTS.	CMPT. WIDTH
HWDR312-■	6	7.55"
	6	9.56"

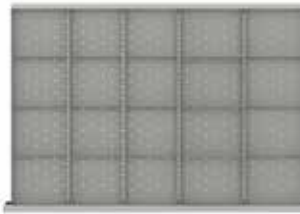

For all drawer heights

PART NO.	COMPTS.	CMPT. WIDTH
HWDR420-■	12	6.21"
	8	7.55"

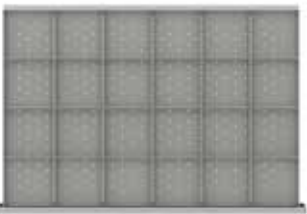

For all drawer heights

PART NO.	COMPTS.	CMPT. WIDTH
HWDR524-■	24	5.50"

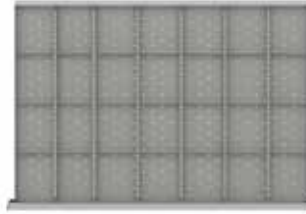

For drawer heights 75 through 200

PART NO.	COMPTS.	CMPT. WIDTH
HWDR628-■	20	4.87"
	8	4.20"



For drawer heights 75 through 125

PART NO.	COMPTS.	CMPT. WIDTH
HWDR024-■	24	6" x 6"

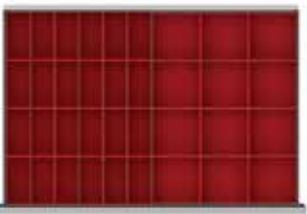

For drawer heights 75 through 125

PART NO.	COMPTS.	CMPT. WIDTH
HWDR036-■	24	3" x 6"
	12	6" x 6"

How to order an MW Width Drawer Preconfigured Interior Set

To order the drawer interior sets shown on this page, use the part number in the chart and add the drawer height in place of the green box.

EXAMPLE: to order an MWDR203 drawer interior set for a 100 height (3") drawer, the part ordering number would be **MWDR203-100**.



For all drawer heights		
PART NO.	COMPARTMENTS	COMPART. WIDTH
MWDR203-█	3	14"



For all drawer heights		
PART NO.	COMPARTMENTS	COMPART. WIDTH
MWDR-LR209-█	9	7.50"

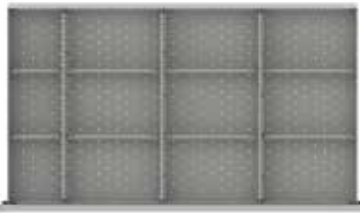

For all drawer heights		
PART NO.	COMPARTMENTS	COMPART. WIDTH
MWDR312-█	3	6.25"
	9	11.50"



For all drawer heights		
PART NO.	COMPARTMENTS	COMPART. WIDTH
MWDR-LR312-█	12	5.50"



For all drawer heights		
PART NO.	COMPARTMENTS	COMPART. WIDTH
MWDR420-█	4	6.25"
	8	7.50"
	8	9.50"



For drawer heights 75 through 150		
PART NO.	COMPARTMENTS	COMPART. WIDTH
MWDR-LR518-█	18	3.50"

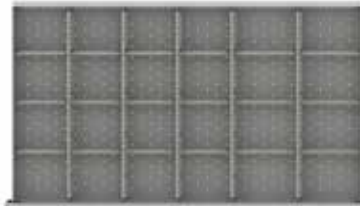

For drawer heights 75 through 300		
PART NO.	COMPARTMENTS	COMPART. WIDTH
MWDR524-█	16	6.25"
	8	7.50"



For drawer heights 75 through 300		
PART NO.	COMPARTMENTS	COMPART. WIDTH
MWDR628-█	24	5.50"
	4	6.25"



For drawer heights 75 through 300		
PART NO.	COMPARTMENTS	COMPART. WIDTH
MWDR635-█	30	5.50"
	5	6.25"



For drawer heights 75 through 200		
PART NO.	COMPARTMENTS	COMPART. WIDTH
MWDR732-█	32	4.875"



For drawer heights 75 through 200		
PART NO.	COMPARTMENTS	COMPART. WIDTH
MWDR836-█	32	4.125"
	4	4.875"

How to order an DW Width

Preconfigured Drawer Interior Set

To order the drawer interior sets shown on this page, use the part number in the chart and add the drawer height in place of the green box.

EXAMPLE: to order a DWDR203 drawer interior set for a 100 height (3") drawer, the part ordering number would be **DWDR203-100**.



For all drawer heights		
PART NO.	COMPARTMENTS	COMPART. WIDTH
DWDR203-█	3	17.25"



For all drawer heights		
PART NO.	COMPARTMENTS	COMPART. WIDTH
DWDR-LR209-█	9	7.50"

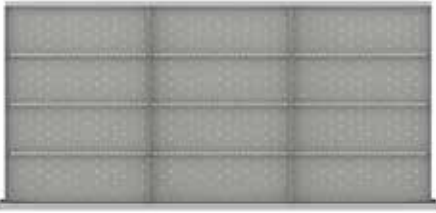

For all drawer heights		
PART NO.	COMPARTMENTS	COMPART. WIDTH
DWDR-LR312-█	12	5.50"



For drawer heights 75 through 300		
PART NO.	COMPARTMENTS	COMPART. WIDTH
DWDR410-█	8	9.50"
	2	11.50"

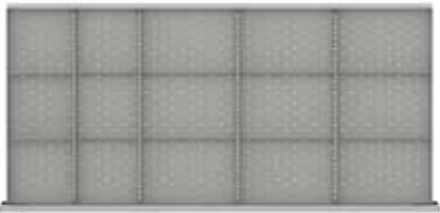

For all drawer heights		
PART NO.	COMPARTMENTS	COMPART. WIDTH
DWDR415-█	6	7.50"
	9	11.50"



For drawer heights 75 through 150		
PART NO.	COMPARTMENTS	COMPART. WIDTH
DWDR-LR518-█	18	3.50"

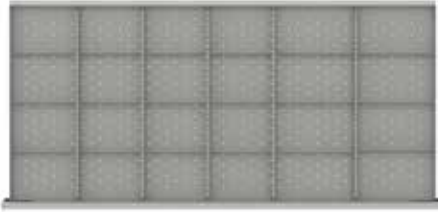

For all drawer heights		
PART NO.	COMPARTMENTS	COMPART. WIDTH
DWDR524-█	16	7.50"
	8	9.50"

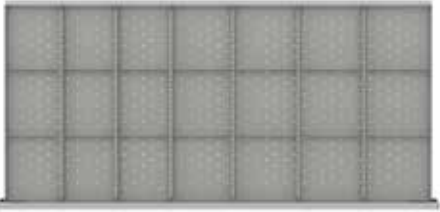

For drawer heights 75 through 300		
PART NO.	COMPARTMENTS	COMPART. WIDTH
DWDR621-█	9	6.25"
	12	7.50"

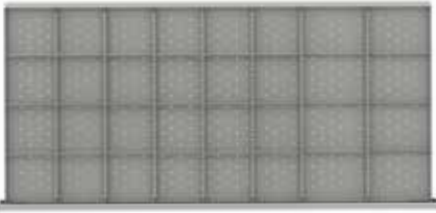

For drawer heights 75 through 300		
PART NO.	COMPARTMENTS	COMPART. WIDTH
DWDR732-█	24	5.50"
	8	7.50"

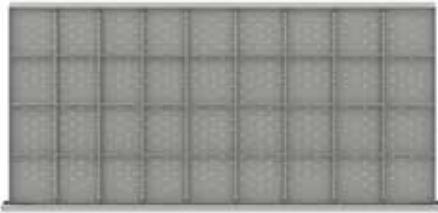

For drawer heights 75 through 200		
PART NO.	COMPARTMENTS	COMPART. WIDTH
DWDR836-█	12	5.25"
	24	5.50"

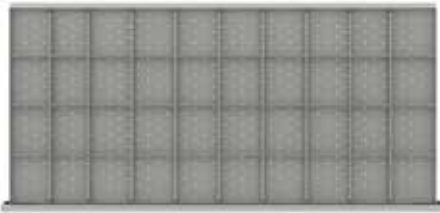

For drawer heights 75 through 200		
PART NO.	COMPARTMENTS	COMPART. WIDTH
DWDR940-█	8	4.125"
	32	4.875"

CABINETS: Shelf Cabinets

Shelf cabinets are an efficient means for storing bulky items that don't lend themselves to drawer storage. Shelf cabinets are built with the same all-steel construction as all Lista cabinets.

Sliding door shelf cabinets are often stacked on complementary sized drawer cabinets, so smaller drawer contents and bulky items can be stored and locked together. The sliding door lock can be positioned at the door bottom to facilitate stacking.



Lista rides to the rescue at Harley Davidson's Vehicle Maintenance and Repair Department. Lista sliding door shelf cabinets, housing large items such as motor oil, greasing and cleaning agents, sit atop drawer cabinets, which store small parts such as nuts, bolts and o-rings.



At the Production Control Center of San Diego's Naval Air Depot, double hinged door cabinets safely and securely store a wide variety of electronic test equipment and supplies used for the precision modification and repair of tactical air navigation transmission boxes.



Stacked sliding door cabinets at Marine Spill, a marine emergency response company, maximize use of available floor space, while providing inventory control and fast retrieval.

SLIDING AND HINGED DOOR SHELF CABINETS

Shelves have a maximum load capacity of 440 lbs. (200kg) evenly distributed and can be moved up or down in 1" increments for the greatest flexibility in arrangement. All units have a stationary bottom shelf and are equipped with the number of adjustable shelves shown in the charts to the right. Optional vertical dividers are also available. All models are shipped fully assembled as described. (See page 80-81 for cabinet dimensions.)



Self-Adhesive Label Holders

Plastic hinged label holder adheres to face of shelf to allow identification of shelf contents. 13/16" high. Does not include label paper. For Lista Script, use 18.932 labels.

PART NO.	LENGTH
18.926	4 1/8" (105mm)
18.927	8 1/4" (210mm)
18.929	39 3/8" (1000mm)

Additional Adjustable Shelves and Shelf Dividers

Made of steel sheet with reinforcing ribs welded on, each shelf has a load capacity of 440 lbs. Support brackets included.

Color: gray.

PART NO.	DESCRIPTION	HT.
VSD100/36	4" shelf divider	4"(102mm)
VSD150/36	6" shelf divider	6"(152mm)

SHALLOW DEPTH SHELF AND DIVIDERS

VSD100/27	4" shelf divider	4"(102mm)
VSD150/27	6" shelf divider	6"(152mm)

Extra Shelves

DEPTH	PART NO.			
Full	EW-AS	HW-AS	MW-AS	DW-AS
Shallow	ES-AS	HS-AS	MS-AS	HT-AS

How to order a Preconfigured Shelf Cabinet

1. Select cabinet from charts.

2. ■ Select base type.

- NB = none
- FT = fork truck
- 2LB = 2" leveling base
- 4LB = 4" leveling base

Additional bases for all cabinets can be found on page 85.

3. ■ Select lock type.

- RG = individual
- KA = keyed-alike
- MA = master

Lock is required. For additional lock options, see page 82-83. To have lock installed at bottom of sliding or hinged door, add "/LB" to the end of the part number.

4. Select paint color. For color chart, see inside back cover.

EXAMPLE: to order a DWSD900 cabinet with no base, an individual lock installed at the bottom of the door and Bright Blue paint, the part number would be **DWSD900-NBRGBB/LB**



Sliding Door Shelf Cabinets

Sliding doors roll smoothly to give access to 50% of cabinet interior at a time.

Full Depth Sliding Doors (SD) Cabinets

EW PART NO.	HW PART NO.	MW PART NO.	DW PART NO.	QTY* OF ADJ. SHELVES
EWSD450	HWSD450	MWSD450	DWSD450	0
EWSD600	HWSD600	MWSD600	DWSD600	1
EWSD750	HWSD750	MWSD750	DWSD750	2
EWSD900	HWSD900	MWSD900	DWSD900	2
EWSD1050	HWSD1050	MWSD1050	DWSD1050	2
EWSD1200	HWSD1200	MWSD1200	DWSD1200	3
EWSD1350	HWSD1350	MWSD1350	DWSD1350	3
EWSD1500	HWSD1500	MWSD1500	-	3

*Quantity not including bottom shelf

Shallow Depth Sliding Doors (SD) Cabinets

ES PART NO.	HS PART NO.	MS PART NO.	HT PART NO.	QTY* OF ADJ. SHELVES
ESSD450	HSSD450	MSDD450	HTSD450	0
ESSD600	HSSD600	MSDD600	HTSD600	1
ESSD750	HSSD750	MSDD750	HTSD750	2
ESSD900	HSSD900	MSDD900	HTSD900	2
ESSD1050	HSSD1050	MSDD1050	HTSD1050	2
ESSD1200	HSSD1200	MSDD1200	HTSD1200	3
ESSD1350	HSSD1350	MSDD1350	HTSD1350	3
ESSD1500	HSSD1500	MSDD1500	-	3

*Quantity not including bottom shelf

Hinged Door Shelf Cabinets

Double hinged doors open to give complete access to cabinet interior.

Full Depth Hinged Doors (HD) Shelf Cabinets

EW PART NO.	HW PART NO.	MW PART NO.	DW PART NO.	QTY* OF ADJ. SHELVES
EWHD450	HWHD450	MWHD450	DWHD450	0
EWHD600	HWHD600	MWHD600	DWHD600	1
EWHD750	HWHD750	MWHD750	DWHD750	2
EWHD900	HWHD900	MWHD900	DWHD900	2
EWHD1050	HWHD1050	MWHD1050	DWHD1050	3
EWHD1200	HWHD1200	MWHD1200	DWHD1200	3
EWHD1350	HWHD1350	MWHD1350	DWHD1350	3
EWHD1500	HWHD1500	MWHD1500	-	3

*Quantity not including bottom shelf

Shallow Depth Hinge Doors (HD) Shelf Cabinets

ES PART NO.	HS PART NO.	MS PART NO.	HT PART NO.	QTY* OF ADJ. SHELVES
ESHD450	HSHD450	MSHD450	HTHD450	0
ESHD600	HSHD600	MSHD600	HTHD600	1
ESHD750	HSHD750	MSHD750	HTHD750	2
ESHD900	HSHD900	MSHD900	HTHD900	2
ESHD1050	HSHD1050	MSHD1050	HTHD1050	3
ESHD1200	HSHD1200	MSHD1200	HTHD1200	3
ESHD1350	HSHD1350	MSHD1350	HTHD1350	3
ESHD1500	HSHD1500	MSHD1500	-	3

*Quantity not including bottom shelf

HOW TO ORDER A CUSTOM CONFIGURED CABINET

Select cabinet housing

Select the particular cabinet housing that best suits your needs. When choosing your housing height, keep in mind the cabinet top's potential use as a worksurface. See page 86.

Select a lock

Choose from a wide array of locking options. See page 82–83.

Select a cabinet base (optional)

A number of optional bases to suit a wide variety of uses. See page 84–85.

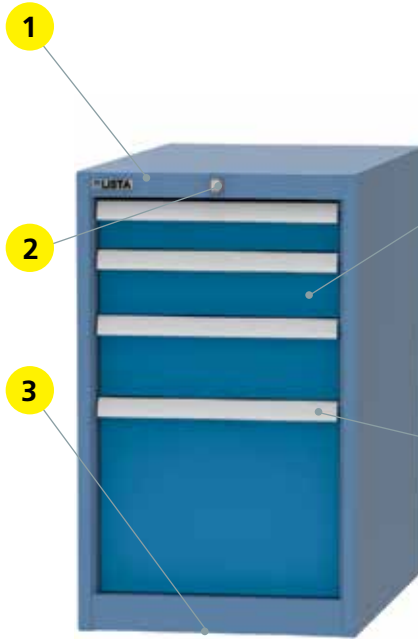

Select drawers, shelves, roll-out trays and doors

Drawers, shelves and roll-out trays can be used in any sequence or combination you wish. See pages 88–89.

Select drawer handle cover option

Drawers come standard with hinged handle cover/label holder but when labeling is not required covers can be upgraded. Three finishes of an aluminum extruded cover are available. See page 90.

The total drawer and/or door model numbers must add up to the model number of the housing.

EXAMPLES:

Model 900 Housing

(2) 100 drawers	=	200
(2) 150 drawers	=	300
(2) 200 drawers	=	400
		<hr/>
		900

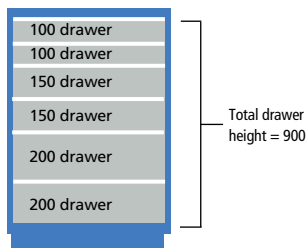

(2) 150 drawers	=	300
(1) 600 drawers	=	400
		<hr/>
		900

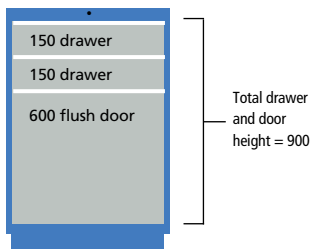

Sample Cabinet Order

QUANTITY	PART NO.	DESCRIPTION
1	SC900	housing
1	KA	keyed alike lock
1	SC-FTB	fork truck base
1	SC1BCT	butcher block top
2	SC100F	drawers
2	SC150F	drawers
2	SC200F	drawers
2	DR316-100	drawer interiors
2	DR206-150	drawer interiors
2	DR104-200	drawer interiors
	Housing: BB	Bright Blue
	Drawers: LG	Light Gray

CHOOSING THE CORRECT CABINET AND DRAWER SIZE(S)

When selecting your cabinet and drawers you will need to consider all of the following:

- The size of the items you will be storing from both a plan and elevation perspective
 - See usable drawer dimensions on next pages to determine if items will fit within the drawer
 - See usable height in the drawer table to select the appropriate drawer height
- The area within your facility you have available
 - See cabinet footprint dimensions on next pages to select the model required (drawer and cabinet footprint designation must match)
- The aisle space required between cabinets and in front of cabinet for proper access to drawer contents
 - Below you can see the typical space requirements for both full and shallow depth cabinet aisles



This overhead view shows two rows of Lista shallow depth cabinets on either side of a comfortable 36" wide access aisle. The aisle leaves enough room for a fully extended drawer and the person accessing it. The cabinets and aisle occupy a total depth of 6' 9".

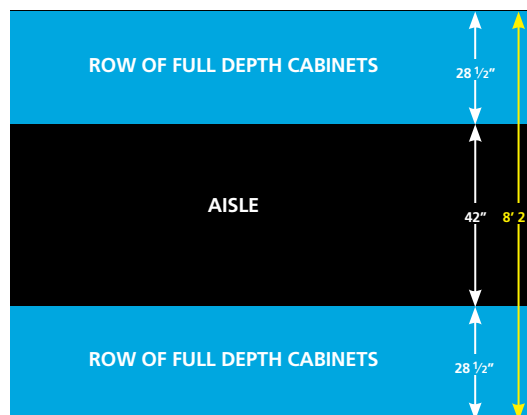

This overhead view shows two rows of industry standard cabinets on either side of a 42" wide access aisle. This width aisle is required to accommodate a fully extended standard drawer and the person accessing it. The cabinets and aisle occupy a total depth of 8' 2".



HOUSING HEIGHT:

For both Full and Shallow Depth Cabinets



Dimensions: Full Depth Housing Footprint and Usable Drawer Space

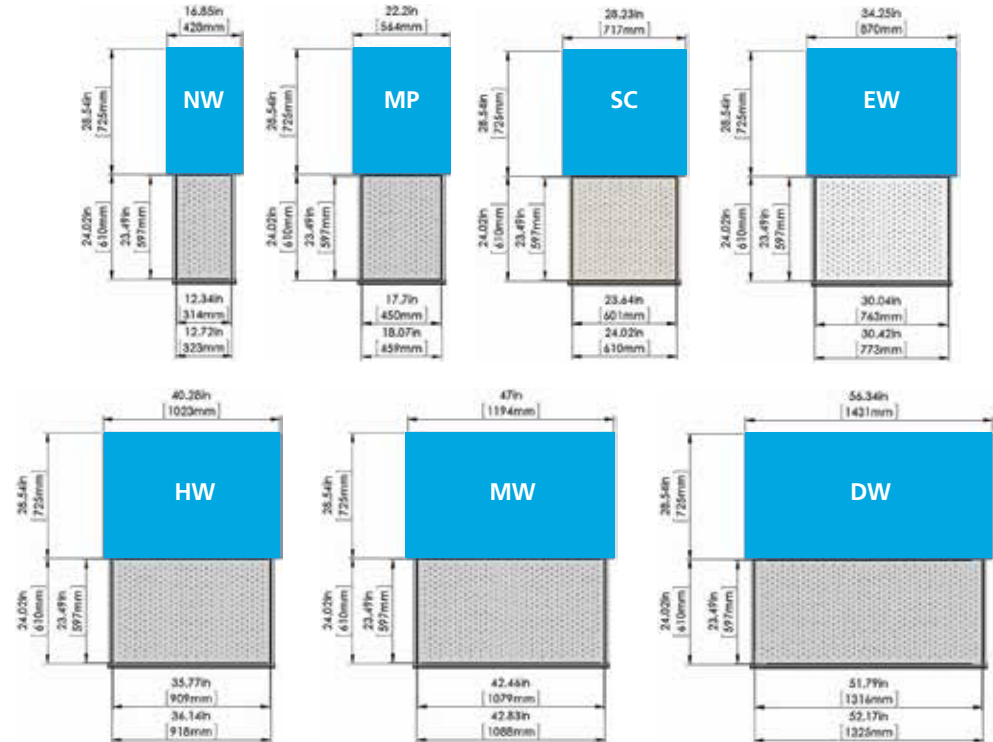

1. Select your Full Depth Housing

Full Depth								
Model Ht. (Points)	Cabinet Height	NW	MP	SC	EW	HW	MW	DW
300	15.75" (400mm)	NW300	MP300	SC300	EW300	HW300	MW300	
450	21.65" (550mm)	NW450	MP450	SC450	EW450	HW450	MW450	DW450
600	27.56" (700mm)	NW600	MP600	SC600	EW600	HW600	MW600	DW600
750	33.46" (850mm)	NW750	MP750	SC750	EW750	HW750	MW750	DW750
900	39.37" (1000mm)	NW900	MP900	SC900	EW900	HW900	MW900	DW900
1050	45.28" (1150mm)	NW1050	MP1050	SC1050	EW1050	HW1050	MW1050	DW1050
1200	51.18" (1300mm)	NW1200	MP1200	SC1200	EW1200	HW1200	MW1200	DW1200
1350	57.09" (1450mm)	NW1350	MP1350	SC1350	EW1350	HW1350	MW1350	DW1350
1500	62.99" (1600mm)	NW1500	MP1500	SC1500	EW1500	HW1500	MW1500	



MODEL 1050 45 1/4" overall height
MODEL 1200 51 9/16" overall height
MODEL 1350 57 1/8" overall height
MODEL 1500 63" overall height

Dimensions: Shallow Depth
 Housing Footprint and Usable Drawer Space

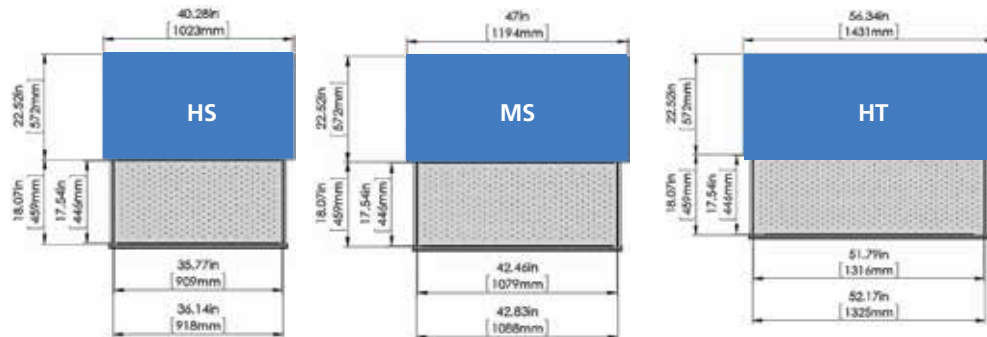
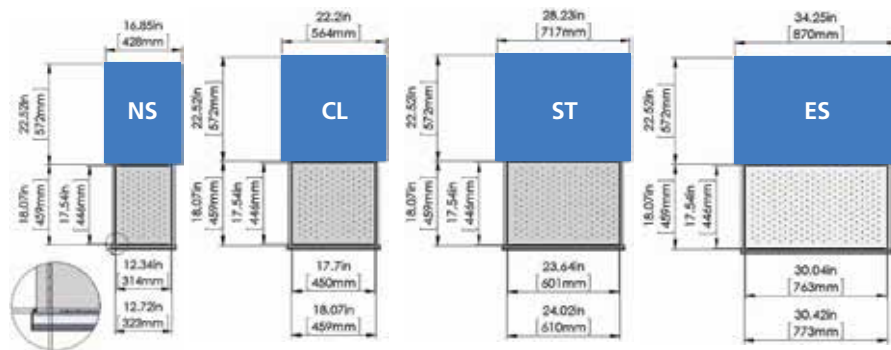

Shallow Depth

1. Select your Shallow Depth Housing



Shallow Depth

Model Ht. (Points)	Cabinet Height	NS	CL	ST	ES	HS	MS	HT
200	11.81" (300mm)	NS200						
300	15.75" (400mm)	NS300	CL300	ST300	ES300	HS300	MS300	
450	21.65" (550mm)	NS450	CL450	ST450	ES450	HS450	MS450	HT450
600	27.56" (700mm)	NS600	CL600	ST600	ES600	HS600	MS600	HT600
750	33.46" (850mm)	NS750	CL750	ST750	ES750	HS750	MS750	HT750
900	39.37" (1000mm)	NS900	CL900	ST900	ES900	HS900	MS900	HT900
1050	45.28" (1150mm)		CL1050	ST1050	ES1050	HS1050	MS1050	HT1050
1200	51.18" (1300mm)		CL1200	ST1200	ES1200	HS1200	MS1200	HT1200
1350	57.09" (1450mm)		CL1350	ST1350	ES1350	HS1350	MS1350	HT1350
1500	62.99" (1600mm)			ST1500	ES1500	HS1500	MS1500	

2. SELECT LOCK AND KEYING OPTIONS

If you have locking and security needs other than the individual lock (lock and 2 keys) that comes with all cabinets, select from the options below.

Individual Lock (RG)

- Cabinets come with an individual lock and 2 keys
- Each cabinet lock is keyed differently

No Lock (NL)

- Specify if no cylinder lock is desired for cabinet housing
- Cabinet will still include PrevenTip® one-drawer-at-a-time safety feature
- Not available for double hinged door cabinets

Key Pad (KP) Lock

- Able to program up to 25 different user codes
- Eliminates lost keys
- retrofittable into existing Lista drawer cabinets/door

PART NO.	LOCK TYPE
KP/CAB	Cabinet Factory Installed
KP/CAB-RETRO	Cabinet Field Installed
KP/FD-DR	Flush Door Factory Installed
KP/FD-DR-RETRO	Flush Door Field Installed

Keyed Alike Lock (KA)

- All cabinets have identical locks, each with 2 keys; the same key opens all cabinets
- Each cabinet in the keyed alike group must have keyed alike (KA) specified on the order
- Cabinets containing drawers and doors will only be keyed alike if specified

PART NO.	LOCK TYPE
KA	keyed alike lock

Master Keyed Lock (MA)

- Each cabinet has a different lock with 2 keys
- Each cabinet in the master key group must have master keyed lock (MA) specified on the order
- Master key (MK) that opens all locks must be ordered separately

PART NO.	LOCK TYPE
MA	master lock
MK	group master key
GMK	grand master key

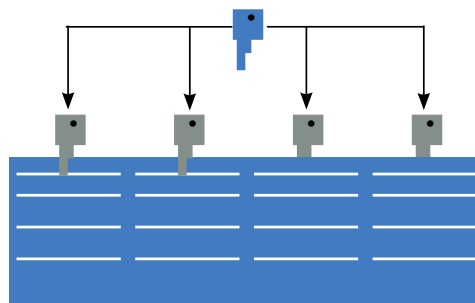
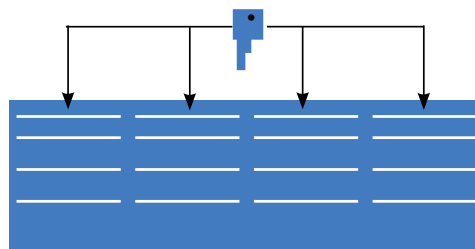
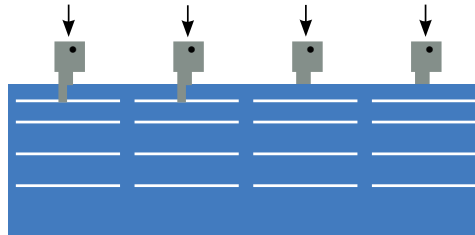

Hasp Lock

Rotates 90° clockwise to disengage latch. For use with hinged and double hinged doors (cannot be used with single hinged flush doors or retractable doors). Secured with padlock (not included). Maximum padlock latch diameter is $\frac{3}{8}$ ". For ordering information, please contact your Lista representative.



Hinged Locking Bars

Particularly suitable for mobile applications or wherever additional security is desired. Hinged locking bar mounts to the left or right of any drawer cabinet on the vertical housing support. Indicate side for mounting by writing an "L" for left or "R" for right in place of the red box ■ in the part number. A padlock (not included) secures the bar. Maximum padlock latch diameter is $\frac{5}{16}$ ". To retrofit to existing cabinet, please contact your Lista representative.



PART NO.	FOR CABINET HEIGHT
HLB300-■	300
HLB450-■	450
HLB600-■	600
HLB750-■	750
HLB900-■	900
HLB1050-■	1050
HLB1200-■	1200
HLB1225-■	1225
HLB1350-■	1350
HLB1500-■	1500
HLB1525-■	1525

Security Panel

Individual locks for each drawer, with a central lock for the cabinet as a whole. Each drawer has a steel security panel between it and the drawer above, so contents are secure even when individual drawers have been removed. Available only for NW, MP, SC and ST Width cabinets and drawer sizes 125, 175, 225, 275, 325 and 350. For ordering information, please contact your Lista representative.



Core Lock

Lista's cylinder lock comes standard with all drawer cabinets. It features a removable core that can be easily removed from the cylinder housing using a release tool (must be ordered separately, see below). Each lock is provided with 2 keys.

Replacement Lock Assemblies

Used to replace locks installed before March 2005.

PART NO.	LOCK TYPE
IC-CYL-RG	individual cylinder lock
IC-CYL-KA	keyed alike cylinder lock
IC-CYL-MA	master cylinder lock
IC-MDR-RG	individual flush door lock
IC-MDR-KA	keyed alike flush door lock
IC-MDR-MA	master flush door lock



Replacement Lock Cores

For field replacement of lock cores. Available for drawer housing and flush door locks shipped after March 2005.

PART NO.	LOCK TYPE
IC-CORE-RG	individual
IC-CORE-KA	keyed alike
IC-CORE-MA	master



Lock Core Release Tool

For extracting interchangeable cylinder core. Works only in conjunction with the original Lista key supplied with the core.

PART NO.	DESCRIPTION
IC-REL-TOOL	lock release tool



Locking Option Application Chart

PART NO.	LOCK TYPE	DRAWER CABINET	FLUSH DOORS	RETRACT. DOORS	DOUBLE HINGED DOORS	SLIDING DOORS	TAMBOUR DOORS
NL	No Lock	✓	✓	✓			
RG	Regular Lock	✓	✓	✓	✓	✓	✓
KA	Keyed alike Lock	✓	✓	✓	✓	✓	✓
MA	Master Series Lock	✓	✓	✓	✓	✓	✓
KP	Keypad Lock	✓	✓				
/H	Hasp Lock		✓	✓	✓		
HLB-300	Hinged Locking Bar	✓	✓	✓			
HLB-450	Hinged Locking Bar	✓	✓	✓			
HLB-600	Hinged Locking Bar	✓	✓	✓			
HLB-750	Hinged Locking Bar	✓	✓	✓			
HLB-900	Hinged Locking Bar	✓	✓	✓			
HLB-1050	Hinged Locking Bar	✓	✓	✓			
HLB-1200	Hinged Locking Bar	✓	✓	✓			
HLB-1225	Hinged Locking Bar	✓	✓	✓			
HLB-1350	Hinged Locking Bar	✓	✓	✓			
HLB-1500	Hinged Locking Bar	✓	✓	✓			
HLB-1525	Hinged Locking Bar	✓	✓	✓			

3. SELECT BASE (OPTIONAL)

Leveling Base

Allows for quick and easy leveling from inside of cabinet. Includes a front cover that adjusts as cabinet is leveled. Base is available in multiple heights in cold-rolled, galvanealed steel steel with matching covers or stainless steel cover option. Adjustment tool, side skirts, anchor kit and glide cap kit are also available.



Fork Truck Base

Steel fork truck base permits moving of fully loaded cabinets. Base has snap-on front and rear covers, and is recessed 1 1/8" (30mm) from the front of the housing. Bases are pre-punched to allow stacking. Color: to match housing.



Wet Clean Base

Allows for easy cleaning below housing in areas where floors are often washed (such as labs and hospitals), or where wet floors are an issue. Raises cabinet housing 4 9/16" above floor. Individual leg height is further adjustable to allow for leveling (up to 1 3/4" additional height), even on extremely uneven surfaces. Cabinet can be lifted and moved with a hand pallet truck.



Mobile Caster Base

A set of 2 fixed and 2 swivel casters. Each swivel caster has an individual wheel lock. Casters are factory mounted to the base. (See page 108–109 for other mobile accessories.)



Frame Base

Steel base is used to bring cabinets up to desired work height. Base is recessed 1 1/8" (30mm) from the front of the housing. Color: to match housing.



FULL DEPTH BASES

TYPE	OVERALL BASE HEIGHT	WHEEL DIA. X WIDTH	WEIGHT CAPACITY	NW PART NO.	MP PART NO.	SC PART NO.	EW PART NO.	HW PART NO.	MW PART NO.	DW PART NO.	*MI PART NO.
Leveling Base	2"		8000 lbs.		LB-MP2	LB-SC2	LB-EW2	LB-HW2	LB-MW2	LB-DW2	LB-MI2
	4"		8000 lbs.		LB-MP4	LB-SC4	LB-EW4	LB-HW4	LB-MW4	LB-DW4	LB-MI4
	6"		8000 lbs.		LB-MP6	LB-SC6	LB-EW6	LB-HW6	LB-MW6	LB-DW6	LB-MI6
Fork Truck Base	2.36"			NW-FTB	MP-FTB	SC-FTB	EW-FTB	HW-FTB	MW-FTB	DW-FTB	*MI-FTB
Wet Clean Base	4.56" - 6"			WCB-NW	WCB-MP	WCB-SC	WCB-EW	WCB-HW	WCB-MW	WCB-DW	WCB-MI
Mobile Base	4.75"	3.5" x 1.25"	900 lbs.	CB-NW3.5X1							
	5.6"	4" x 1.25"	1000 lbs.		CB-MP4X1	CB-SC4X1	CB-EW4X1	CB-HW4X1	CB-MW4X1	CB-DW4X1	CB-MI4X1
	6.2"	4" x 2"	1400 lbs.		CB-MP4B	CB-SC4B	CB-EW4B	CB-HW4B	CB-MW4B	CB-DW4B	CB-MI4B
	6.2"	4" x 2"	2400 lbs.		CB-MP4ML	CB-SC4ML	CB-EW4ML	CB-HW4ML	CB-MW4ML	CB-DW4ML	CB-MI4ML
	8"	6" x 2"	2400 lbs.		CB-MP6B	CB-SC6B	CB-EW6B	CB-HW6B	CB-MW6B	CB-DW6B	CB-MI6B
	8"	6" x 2"	3600 lbs.		CB-MP6ML	CB-SC6ML	CB-EW6ML	CB-HW6ML	CB-MW6ML	CB-DW6ML	CB-MI6ML
	8"	6" x 2"	4800 lbs.		CB-MP6TS/TL	CB-SC6TS/TL	CB-EW6TS/TL	CB-HW6TS/TL	CB-MW6TS/TL	CB-DW6TS/TL	CB-MI6TS/TL
	8"	6" x 2"	4800 lbs.		CB-MP6TS/TL	CB-SC6TS/TL	CB-EW6TS/TL	CB-HW6TS/TL	CB-MW6TS/TL	CB-DW6TS/TL	CB-MI6TS/TL
Frame Base	2"			NW-2							
	4"			NW-4							
	6"			NW-6							
Glide Kit	Adds 0.4"		GLIDE/KIT								
Frame Base	2.4"			NW-2G							
w/Glides	4.4"			NW-4G							
	6.4"			NW-6G							

SHALLOW DEPTH BASES

TYPE	OVERALL BASE HEIGHT	WHEEL DIA. X WIDTH	WEIGHT CAPACITY	NS PART NO.	CL PART NO.	ST PART NO.	ES PART NO.	HS PART NO.	MS PART NO.	HT PART NO.	*ML PART NO.
Leveling Base	2"		8000 lbs.		LB-CL2	LB-ST2	LB-ES2	LB-HS2	LB-MS2	LB-HT2	LB-ML2
	4"		8000 lbs.		LB-CL4	LB-ST4	LB-ES4	LB-HS4	LB-MS4	LB-HT4	LB-ML4
	6"		8000 lbs.		LB-CL6	LB-ST6	LB-ES6	LB-HS6	LB-MS6	LB-HT6	LB-ML6
Fork Truck Base	2.36"			NS-FTB	CL-FTB	ST-FTB	ES-FTB	HS-FTB	MS-FTB	HT-FTB	*ML-FTB
Wet Clean Base	4.56" - 6"			WCB-NS	WCB-CL	WCB-ST	WCB-ES	WCB-HS	WCB-MS	WCB-HT	WCB-ML
Mobile Base	4.75"	3.5" x 1.25"	900 lbs.	CB-NS3.5X1							
	5.6"	4" x 1.25"	1000 lbs.		CB-CL4X1	CB-ST4X1	CB-ES4X1	CB-HS4X1	CB-MS4X1	CB-HT4X1	CB-ML4X1
	6.2"	4" x 2"	1400 lbs.		CB-CL4B	CB-ST4B	CB-ES4B	CB-HS4B	CB-MS4B	CB-HT4B	CB-ML4B
	6.2"	4" x 2"	2400 lbs.		CB-CL4ML	CB-ST4ML	CB-ES4ML	CB-HS4ML	CB-MS4ML	CB-HT4ML	CB-ML4ML
	8"	6" x 2"	2400 lbs.		CB-CL6B	CB-ST6B	CB-ES6B	CB-HS6B	CB-MS6B	CB-HT6B	CB-ML6B
	8"	6" x 2"	3600 lbs.		CB-CL6ML	CB-ST6ML	CB-ES6ML	CB-HS6ML	CB-MS6ML	CB-HT6ML	CB-ML6ML
	8"	6" x 2"	4800 lbs.		CB-CL6TS/TL	CB-ST6TS/TL	CB-ES6TS/TL	CB-HS6TS/TL	CB-MS6TS/TL	CB-HT6TS/TL	CB-ML6TS/TL
	8"	6" x 2"	4800 lbs.		CB-CL6TS/TL	CB-ST6TS/TL	CB-ES6TS/TL	CB-HS6TS/TL	CB-MS6TS/TL	CB-HT6TS/TL	CB-ML6TS/TL
Frame Base	2"			NS-2							
	4"			NS-4							
	6"			NS-6							
Glide Kit	Adds 0.4"		GLIDE/KIT								
Frame Base	2.4"			NS-2G							
w/Glides	4.4"			NS-4G							
	6.4"			NS-6G							

4. SELECT CABINET TOP OR COUNTER TOP (OPTIONAL)

Retainer Tops with Mat

Retainer top, painted to match housing with raised edges on back and sides, provides a practical non-skid worksurface. Height is $\frac{3}{4}$ ". Ribbed mat is included.



Butcher Block Cabinet Tops

Tops are satin finish $1\frac{3}{4}$ " thick hardwood and are flush to the cabinet side-to-side and front-to-back.



Plastic Laminate Cabinet Tops

Tops are $1\frac{5}{16}$ " thick plastic laminate over particle board core and are flush to the cabinet side-to-side and front-to-back. Dove gray is standard but other colors are available on request.



Stainless Steel Cabinet Covers

Cover is constructed of durable, heavy gauge stainless steel. Fits over top and sides of cabinet, and provides easy access to locking system. Adds $\frac{1}{16}$ " to overall cabinet height and $\frac{1}{8}$ " to overall width and depth.



Phenolic Resin Cabinet Tops

Top is a high-pressure laminate designed for laboratory worksurfaces and mounts flush to the cabinet side-to-side and front-to-back. Resistant to chemicals, stains or discoloration. Top is 1" thick phenolic resin, available in black.



Stainless Steel Over Wood Core (SS)

Worksurface is constructed of durable heavy gauge, 304 stainless steel cover, fitted over top and sides of wood core, $1\frac{13}{16}$ " thick.



Cabinet Tops - Full Depth

TOP TYPE	# OF CABINETS	NW	MP	SC	EW	HW	MW	DW
Retainer Top w/Mat	1	NW-RT	MP-RT	SC-RT	EW-RT	HW-RT	MW-RT	DW-RT
Retainer Top w/Mat	2	2NW-RT	2MP-RT	-	-	-	-	-
Butcher Block	1	NW1BCT	MP1BCT	SC1BCT	EW1BCT	HW1BCT	MW1BCT	DW1BCT
Plastic Laminate	1	NW1PCT	MP1PCT	SC1PCT	EW1PCT	HW1PCT	MW1PCT	SC2PCT
Stainless Steel Cabinet Cover	1	NW1SSC	MP1SSC	SC1SSC	EW1SSC	HW1SSC	MW1SSC	DW1SSC
Phenolic Resin	1	NW1RCT	MP1RCT	SC1RCT	EW1RCT	HW1RCT	MW1RCT	SC2RCT

Counter Tops - Full Depth

TOP TYPE	# OF CABS. SPANNED	NW	MP	SC	EW	HW	MW	DW	
Butcher Block	2	NW2BCT	MP2BCT	SC2BCT	EW2BCT	HW2BCT	MW2BCT	SC4BCT	
	3	NW3BCT	MP3BCT	SC3BCT	EW3BCT	-	-	-	
	4	NW4BCT	MP4BCT	SC4BCT	-	-	-	-	
	5	NW5BCT	MP5BCT	-	-	-	-	-	
	Plastic Laminate	2	NW2PCT	MP2PCT	SC2PCT	EW2PCT	HW2PCT	MW2PCT	SC4PCT
Plastic Laminate	3	NW3PCT	MP3PCT	SC3PCT	EW3PCT	-	-	-	
	4	NW4PCT	MP4PCT	SC4PCT	-	-	-	-	
	Stainless Steel Counter Tops	1	NW1LSSCT	MP1LSSCT	SC1LSSCT	EW1LSSCT	HW1LSSCT	MW1LSSCT	SC2LSSCT
		2	NW2LSSCT	MP2LSSCT	SC2LSSCT	EW2LSSCT	HW2LSSCT	MW2LSSCT	SC4LSSCT
3		NW3LSSCT	MP3LSSCT	SC3LSSCT	EW3LSSCT	-	-	-	
4		NW4LSSCT	MP4LSSCT	SC4LSSCT	-	-	-	-	
Phenolic Resin	2	NW2RCT	MP2RCT	SC2RCT	EW2RCT	HW2RCT	MW2RCT	SC4RCT	
	3	NW3RCT	MP3RCT	SC3RCT	EW3RCT	-	-	-	
	4	NW4RCT	MP4RCT	SC4RCT	-	-	-	-	

Cabinet Tops - Shallow Depth

TOP TYPE	# OF CABINETS	NS	CL	ST	ES	HS	MS	HT
Retainer Top w/Mat	1	NS-RT	CL-RT	ST-RT	ES-RT	HS-RT	MS-RT	HT-RT
Butcher Block	1	NS1BCT	CL1BCT	ST1BCT	ES1BCT	HS1BCT	MS1BCT	HT1BCT
Plastic Laminate	1	NS1PCT	CL1PCT	ST1PCT	ES1PCT	HS1PCT	MS1PCT	ST2PCT
Stainless Steel Cabinet Cover	1	NS1SSC	CL1SSC	ST1SSC	ES1SSC	HS1SSC	MS1SSC	HT1SSC
Phenolic Resin	1	NS1RCT	CL1RCT	ST1RCT	ES1RCT	HS1RCT	MS1RCT	ST2RCT

Counter Tops - Shallow Depth

TOP TYPE	# OF CABS. SPANNED	NS	CL	ST	ES	HS	MS	HT
Butcher Block	2	NS2BCT	CL2BCT	ST2BCT	ES2BCT	HS2BCT	MS2BCT	ST4BCT
	3	NS3BCT	CL3BCT	ST3BCT	ES3BCT	-	-	-
	4	NS4BCT	CL4BCT	ST4BCT	-	-	-	-
	5	NS5BCT	CL5BCT	-	-	-	-	-
	Plastic Laminate	2	NS2PCT	CL2PCT	ST2PCT	ES2PCT	HS2PCT	MS2PCT
Plastic Laminate	3	NS3PCT	CL3PCT	ST3PCT	ES3PCT	-	-	-
	4	NS4PCT	CL4PCT	ST4PCT	-	-	-	-
Stainless Steel Counter Tops	1	NS1LSSCT	CL1LSSCT	ST1LSSCT	ES1LSSCT	HS1LSSCT	MS1LSSCT	ST2LSSCT
	2	NS2LSSCT	CL2LSSCT	ST2LSSCT	ES2LSSCT	HS2LSSCT	MS2LSSCT	ST4LSSCT
	3	NS3LSSCT	CL3LSSCT	ST3LSSCT	ES3LSSCT	-	-	-
	4	NS4LSSCT	CL4LSSCT	ST4LSSCT	-	-	-	-
Phenolic Resin	2	NS2RCT	CL2RCT	ST2RCT	ES2RCT	HS2RCT	MS2RCT	ST4RCT
	3	NS3RCT	CL3RCT	ST3RCT	ES3RCT	-	-	-
	4	NS4RCT	CL4RCT	ST4RCT	-	-	-	-

5. SELECT DRAWERS, SHELVES, ROLL-OUT TRAYS AND/OR DOORS

Drawers, shelves and roll-out trays can be arranged and re-arranged in a cabinet housing in any sequence. See the graphic on page 78 for information on configuring the correct height(s) of drawers and doors to fit the housing you have selected.

Drawers

Drawers are 100% full extension, allowing complete use of the furthest corners and easy access to all contents. Each drawer has a maximum load capacity of either 440 lb. (200kg) or 165 lb. (75kg).



Shelves

Fixed bottom shelves and adjustable upper shelves can be moved up or down in 1" increments. Vertical dividers are available to sub-divide shelves. Shelf cabinets are often stacked above drawer cabinets for maximum space savings. Maximum load capacity of 440 lbs. (200kg) evenly distributed.



Roll-Out Trays

Roll-out trays allow easy access to stored items, even in the furthest corner. 100% full extension, 440 lb. (200 kg) or 165 lb. (75kg) maximum load capacity.



Retractable Door

Door slides out and back, stored out of the way when not in use. Door is provided with handles, individual lock (RG) and 2 keys. Only bottom and adjustable shelves may be installed behind retractable doors – no drawers or roll-out trays. See pages 82-83 for lock options.



Options: Add "-P" for window option on 450 and taller
See page 82 for locking options

Full Depth Retractable Doors

MP PART NO.	SC PART NO.	EW PART NO.	HW PART NO.	MW PART NO.	DW PART NO.
RD300/MP	RD300/SC	RD300/EW	RD300/HW	RD300/MW	RD300/DW
RD450/MP	RD450/SC	RD450/EW	RD450/HW	RD450/MW	RD450/DW
RD600/MP	RD600/SC	RD600/EW	RD600/HW	RD600/MW	RD600/DW

Shallow Depth Retractable Doors

CL PART NO.	ST PART NO.	ES PART NO.	HS PART NO.	MS PART NO.	HT PART NO.
RD300/CL	RD300/ST	RD300/ES	RD300/HS	RD300/MS	RD300/HT
RD450/CL	RD450/ST	RD450/ES	RD450/HS	RD450/MS	RD450/HT

Flush Hinged Door

Single door protects cabinet contents. Door is provided with integrated handle (reversible in field to allow door to open in opposite direction), individual lock (RG) and 2 keys. Only bottom and adjustable shelves may be installed behind flush doors – no drawers or roll-out trays, except for MP-TCN roll-out trays in MP width cabinets. See pages 82-83 for lock options.



Flush Hinged Doors

NS/NW PART NO.	CL/MP PART NO.	ST/SC PART NO.
FD300/19	FD300/27	-
FD450/19	FD450/27	FD450/36
FD600/19	FD600/27	FD600/36
FD750/19	FD750/27	FD750/36
FD900/19	FD900/27	FD900/36
FD1050/19	FD1050/27	FD1050/36
FD1200/19	FD1200/27	FD1200/36
FD1350/19	FD1350/27	FD1350/36

Options

add "R" for right hinged or "L" for left hinged
add "-W" for acrylic window cutout (optional)
add "-PF" for perforated cutout (optional)
add "-_" for lock option (RG is default) see pages 80-81 for other locking options

Part number example: *FD 750 27 R -W -KP*

Flush Door
750 Points
27U Width

Keypad Lock
Window Cutout
Right Hinged

Drawers (Full Depth)

HEIGHT (POINTS)	USABLE HEIGHT	SIDEWALL HEIGHT	NW 165 LB. (75KG)	MP 440 LB. (200KG)	SC 440 LB. (200KG)	EW 440 LB. (200KG)	HW 440 LB. (200KG)	MW 440 LB. (200KG)	DW 440 LB. (200KG)
75	2.17" (55mm)	1.97" (50mm)	NW75N	MP75F	SC75F	EW75F	HW75F	MW75F	DW75F
100	3.15" (80mm)	3.03" (77mm)	NW100N	MP100F	SC100F	EW100F	HW100F	MW100F	DW100F
125	4.13" (105mm)	3.03" (77mm)	NW125N	MP125F	SC125F	EW125F	HW125F	MW125F	DW125F
150	5.12" (130mm)	5.00" (127mm)	NW150N	MP150F	SC150F	EW150F	HW150F	MW150F	DW150F
175	6.1" (155mm)	5.00" (127mm)	NW175N	MP175F	SC175F	EW175F	HW175F	MW175F	DW175F
200	7.09" (180mm)	6.97" (177mm)	NW200N	MP200F	SC200F	EW200F	HW200F	MW200F	DW200F
225	8.07" (205mm)	6.97" (177mm)	NW225N	MP225F	SC225F	EW225F	HW225F	MW225F	DW225F
250	9.06" (230mm)	8.94" (227mm)	NW250N	MP250F	SC250F	EW250F	HW250F	MW250F	DW250F
275	10.04" (255mm)	8.94" (227mm)	NW275N	MP275F	SC275F	EW275F	HW275F	MW275F	DW275F
300	11.02" (280mm)	10.91" (277mm)	NW300N	MP300F	SC300F	EW300F	HW300F	MW300F	DW300F
300-FFH	11.02" (280mm)	10.00" (254mm)	NW300-FFH*	-	-	-	-	-	-
325	12.01" (305mm)	10.91" (277mm)	NW325N	MP325F	SC325F	EW325F	HW325F	MW325F	DW325F
325-FFH	12.01" (305mm)	10.00" (254mm)	NW325-FFH*	-	-	-	-	-	-
350	12.99" (330mm)	10.91" (277mm)	NW350N	MP350F	SC350F	EW350F	HW350F	MW350F	DW350F
375	13.98" (355mm)	10.91" (277mm)	NW375N	MP375F	SC375F	EW375F	HW375F	MW375F	DW375F
400	14.96" (380mm)	10.91" (277mm)	NW400N	MP400F	SC400F	EW400F	HW400F	MW400F	DW400F
Bottom Shelf	N/A	1.2" (30mm)	-	MP-BS	SC-BS	EW-BS	HW-BS	MW-BS	DW-BS
Adjustable Shelf	N/A	1.2" (30mm)	NW-AS	MP-AS	SC-AS	EW-AS	HW-AS	MW-AS	DW-AS
TCF Tray	N/A	1.2" (30mm)	-	MP-TCF	SC-TCF	EW-TCF	HW-TCF	MW-TCF	DW-TCF
TCN Tray	N/A	1.2" (30mm)	-	MP-TCN	SC-TCN	-	-	-	-

*Hanging File Folder Drawer (not sub-dividable)

Drawers (Shallow Depth)

HEIGHT (POINTS)	USABLE HEIGHT	SIDEWALL HEIGHT	NS 165 LB. (75KG)	CL 440 LB. (200KG)	ST 440 LB. (200KG)	ES 440 LB. (200KG)	HS 440 LB. (200KG)	MS 440 LB. (200KG)	HT 440 LB. (200KG)
75	2.17" (55mm)	1.97" (50mm)	NS75N	CL75F	ST75F	ES75F	HS75F	MS75F	HT75F
100	3.15" (80mm)	3.03" (77mm)	NS100N	CL100F	ST100F	ES100F	HS100F	MS100F	HT100F
125	4.13" (105mm)	3.03" (77mm)	NS125N	CL125F	ST125F	ES125F	HS125F	MS125F	HT125F
150	5.12" (130mm)	5.00" (127mm)	NS150N	CL150F	ST150F	ES150F	HS150F	MS150F	HT150F
175	6.1" (155mm)	5.00" (127mm)	NS175N	CL175F	ST175F	ES175F	HS175F	MS175F	HT175F
200	7.09" (180mm)	6.97" (177mm)	NS200N	CL200F	ST200F	ES200F	HS200F	MS200F	HT200F
225	8.07" (205mm)	6.97" (177mm)	NS225N	CL225F	ST225F	ES225F	HS225F	MS225F	HT225F
250	9.06" (230mm)	8.94" (227mm)	NS250N	CL250F	ST250F	ES250F	HS250F	MS250F	HT250F
275	10.04" (255mm)	8.94" (227mm)	NS275N	CL275F	ST275F	ES275F	HS275F	MS275F	HT275F
300	11.02" (280mm)	10.91" (277mm)	NS300N	CL300F	ST300F	ES300F	HS300F	MS300F	HT300F
300-FFH	11.02" (280mm)	10.00" (254mm)	NS300-FFH*	-	-	-	-	-	-
325	12.01" (305mm)	10.91" (277mm)	NS325N	CL325F	ST325F	ES325F	HS325F	MS325F	HT325F
325-FFH	12.01" (305mm)	10.00" (254mm)	NS325-FFH*	-	-	-	-	-	-
350	12.99" (330mm)	10.91" (277mm)	NS350N	CL350F	ST350F	ES350F	HS350F	MS350F	HT350F
375	13.98" (355mm)	10.91" (277mm)	NS375N	CL375F	ST375F	ES375F	HS375F	MS375F	HT375F
400	14.96" (380mm)	10.91" (277mm)	NS400N	CL400F	ST400F	ES400F	HS400F	MS400F	HT400F
Bottom Shelf	N/A	1.2" (30mm)	-	CL-BS	ST-BS	ES-BS	HS-BS	MS-BS	HT-BS
Adjustable Shelf	N/A	1.2" (30mm)	NS-AS	CL-AS	ST-AS	ES-AS	HS-AS	MS-AS	HT-AS
TCF Tray	N/A	1.2" (30mm)	-	CL-TCF	ST-TCF	ES-TCF	HS-TCF	MS-TCF	HT-TCF
TCN Tray	N/A	1.2" (30mm)	-	CL-TCN	ST-TCN	-	-	-	-

*Hanging File Folder Drawer (not sub-dividable)

For Preconfigured Shallow Depth Drawer Interiors see pages 32-39. For full depth drawer interiors see pages 66-75. For the full range of drawer interior accessories see pages 262-271.

Drawers come standard with a unique handle cover with a hinged plastic outer cover which allows quick and easy adding or changing of labels while protecting them from handling, tearing and dirt. Drawers and contents can be labeled with free, down-loadable Lista Script software. For those not requiring labeling of drawer or contents aluminum extrude covers are available in three finishes including: gloss black, chrome color, and brushed silver. See page 90.

DRAWER OPTIONS

Drawer Handle Pulls (Optional)

For those not requiring labeling of drawers or contents aluminum extruded covers are available in three finishes including: gloss black, chrome color, and brushed silver.

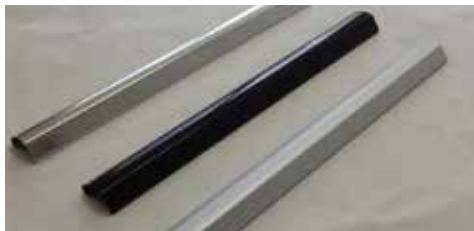

UPGRADE PART NUMBERS (REPLACES SCRIPT HANDLE COVER)

COLORS STYLE WIDTH	BRUSHED SILVER PART NO.	CHROME COLOR PART NO.	GLOSS BLACK PART NO.
NS/NW	HNDL-NSNW/BRSH	HNDL-NSNW/CHRM	HNDL-NSNW/GBLK
CL/MP	HNDL-CLMP/BRSH	HNDL-CLMP/CHRM	HNDL-CLMP/GBLK
ST/SC	HNDL-STSC/BRSH	HNDL-STSC/CHRM	HNDL-STSC/GBLK
ES/EW	HNDL-ESEW/BRSH	HNDL-ESEW/CHRM	HNDL-ESEW/GBLK
HS/HW	HNDL-HSHW/BRSH	HNDL-HSHW/CHRM	HNDL-HSHW/GBLK
ML/MI	HNDL-MLMI/BRSH	HNDL-MLMI/CHRM	HNDL-MLMI/GBLK
MS/MW	HNDL-MSMW/BRSH	HNDL-MSMW/CHRM	HNDL-MSMW/GBLK
HT/DW	HNDL-HTDW/BRSH	HNDL-HTDW/CHRM	HNDL-HTDW/GBLK

REPLACEMENT HANDLES (FOR EXISTING PRODUCT)

COLORS STYLE WIDTH	BRUSHED SILVER PART NO.	CHROME COLOR PART NO.	GLOSS BLACK PART NO.
NS/NW	TDP-NSNW/BRSH	TDP-NSNW/CHRM	TDP-NSNW/GBLK
CL/MP	TDP-CLMP/BRSH	TDP-CLMP/CHRM	TDP-CLMP/GBLK
ST/SC	TDP-STSC/BRSH	TDP-STSC/CHRM	TDP-STSC/GBLK
ES/EW	TDP-ESEW/BRSH	TDP-ESEW/CHRM	TDP-ESEW/GBLK
HS/HW	TDP-HSHW/BRSH	TDP-HSHW/CHRM	TDP-HSHW/GBLK
ML/MI	TDP-MLMI/BRSH	TDP-MLMI/CHRM	TDP-MLMI/GBLK
MS/MW	TDP-MSMW/BRSH	TDP-MSMW/CHRM	TDP-MSMW/GBLK
HT/DW	TDP-HTDW/BRSH	TDP-HTDW/CHRM	TDP-HTDW/GBLK

DRAWER/SHELF SECURITY OPTIONS

Individual Drawer Latch (IDL)

Individual drawer latches lock drawers and roll-out trays closed for safety when moving. Particularly applicable for cabinets in vehicles, mobile cabinets, and where seismic activity is a consideration. Finger pull latch is recessed under the drawer handle. Comes standard with all mobile cabinets. IDL can be added at any time.



Individual Drawer Latch (IDL)

PART NO.	DESCRIPTION
IDL	for right location
IDL-L	for left location

Lock-In-Lock-Out (LILO)

LILO safety device locks drawer in fully opened or fully closed position. Latch is mounted on the lower right face of the drawer. Particularly suitable for vehicles, shipboard and other mobile applications. Factory installed. Only available for 440 lb. (200kg) suspension drawers.



Lock-In-Lock-Out (LILO)

PART NO.	DESCRIPTION
LILO	

Security Shelf Battens

Batten secures to front of housing to keep boxes and other loose items from falling off shelf. Suitable for mobile vehicles, service vans, military containers and aircraft. Usable behind hinged doors, double hinged doors or flush doors (450 height or higher). Made from galvanized steel, unpainted.



Security Shelf Battens

PART NO.	FOR USE WITH
SB-27U	Security Shelf Batten, CL/MP
SB-36U	Security Shelf Batten, ST/SC
SB-45U	Security Shelf Batten, ES/EW
SB-54U	Security Shelf Batten, HS/HW
SB-64U	Security Shelf Batten, MS/MW
SB-78U	Security Shelf Batten, HT/DW

DOUBLE HINGED DOOR (DHD) CABINETS

Available in both full and shallow depth cabinets, adds 1" to cabinet depth, full depth cabinets are 29 1/2" deep and shallow depth cabinets are 23 1/2" deep. Double Hinged Door (DHD) cabinets include a pair of hinged doors that are mounted onto the front of the cabinet and an individual lock with 2 keys. It can be configured with any sequence of drawers, shelves and roll-out trays. For other available options for your DHD cabinet contact your Lista representative.

- Select cabinet
- Select lock (optional)
- Select base (optional)
- Select drawers, trays and/or shelves
- Select drawer interiors (optional)
- Select drawer handle cover (optional)
- (See pages 78–90 for above features)**
- Select color(s) on inside back cover



FULL DEPTH (29 1/2" DEEP) DOUBLE HINGED DOOR (DHD) CABINETS

MP PART NO.	SC PART NO.	EW PART NO.	HW PART NO.	MW PART NO.	DW PART NO.	CABINET HEIGHT
MPDHD450	SCDHD450	EWDHD450	HWDHD450	MWDHD450	DWDHD450	21.65" (550mm)
MPDHD600	SCDHD600	EWDHD600	HWDHD600	MWDHD600	DWDHD600	27.56" (700mm)
MPDHD750	SCDHD750	EWDHD750	HWDHD750	MWDHD750	DWDHD750	33.46" (850mm)
MPDHD900	SCDHD900	EWDHD900	HWDHD900	MWDHD900	DWDHD900	39.37" (1000mm)
MPDHD1050	SCDHD1050	EWDHD1050	HWDHD1050	MWDHD1050	DWDHD1050	45.28" (1150mm)
MPDHD1200	SCDHD1200	EWDHD1200	HWDHD1200	MWDHD1200	DWDHD1200	51.18" (1300mm)
MPDHD1350	SCDHD1350	EWDHD1350	HWDHD1350	MWDHD1350	DWDHD1350	57.09" (1450mm)
MPDHD1500	SCDHD1500	EWDHD1500	HWDHD1500	MWDHD1500	-	62.99" (1600mm)



SHALLOW DEPTH (23 1/2" DEEP) DOUBLE HINGED DOOR (DHD) CABINETS

CL PART NO.	ST PART NO.	ES PART NO.	HS PART NO.	MS PART NO.	HT PART NO.	CABINET HEIGHT
CLDHD450	STDHD450	ESDHD450	HSDHD450	MSDHD450	HTDHD450	21.65" (550mm)
CLDHD600	STDHD600	ESDHD600	HSDHD600	MSDHD600	HTDHD600	27.56" (700mm)
CLDHD750	STDHD750	ESDHD750	HSDHD750	MSDHD750	HTDHD750	33.46" (850mm)
CLDHD900	STDHD900	ESDHD900	HSDHD900	MSDHD900	HTDHD900	39.37" (1000mm)
CLDHD1050	STDHD1050	ESDHD1050	HSDHD1050	MSDHD1050	HTDHD1050	45.28" (1150mm)
CLDHD1200	STDHD1200	ESDHD1200	HSDHD1200	MSDHD1200	HTDHD1200	51.18" (1300mm)
CLDHD1350	STDHD1350	ESDHD1350	HSDHD1350	MSDHD1350	HTDHD1350	57.09" (1450mm)
-	STDHD1500	ESDHD1500	HSDHD1500	MSDHD1500	-	62.99" (1600mm)



FULL DEPTH CABINETS

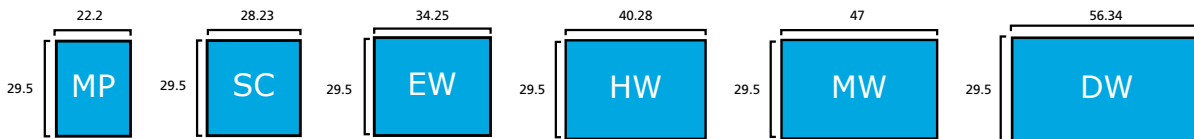

SHALLOW DEPTH CABINETS

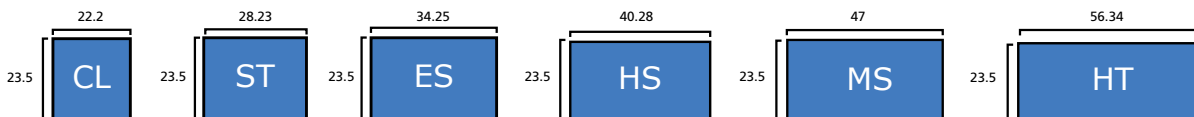

CABINET HOUSING

These cabinets feature full-width top drawer(s), which can store unusually long items safely and securely. The cabinets (either full or shallow depth) can be configured with a variety of drawer sizes, with the option of shelf or roll-out tray storage for bulky items, and with a variety of bases including a mobile base.

To build your own combination cabinet see page 78.

DW/MPEW & DW/SCSC Combination Cabinet Housing

MPEW has MP drawers with a usable width of 18" on bottom left and EW drawers with a usable width of 30.4" on bottom right. SCSC has SC drawers with a usable width of 24" on both bottom left and right.



MI Combination Cabinet Housing

45" wide x 28 1/2" deep - All drawer have a usable depth of 24". MI Top drawers have a usable width of 40 13/16". NWSC has NW drawers with a usable width of 12 1/16" on bottom left and SC drawers with a usable width of 24" on bottom right. Housing accepts MI tops and bases.



Select: Lock Select: Color

See pages 82-90 for details.

DW Housing		56.34" wide x 28.54" deep (1431mm W x 725mm D)			
Part No.	Inches	Cabinet Height		Top Drawers	Bottom Drawers
		Inches	MM's	Available Points	Available Points
DW750-C450/MPEW- <input checked="" type="checkbox"/>	33.46		850	300	450
DW750-C600/MPEW- <input checked="" type="checkbox"/>	33.46		850	150	600
DW900-C600/MPEW- <input checked="" type="checkbox"/>	39.37		1000	300	600
DW900-C750/MPEW- <input checked="" type="checkbox"/>	39.37		1000	150	750
DW1050-C750/MPEW- <input checked="" type="checkbox"/>	45.28		1150	300	750
DW1050-C900/MPEW- <input checked="" type="checkbox"/>	45.28		1150	150	900
DW1200-C900/MPEW- <input checked="" type="checkbox"/>	51.18		1300	300	900
DW1200-C1050/MPEW- <input checked="" type="checkbox"/>	51.18		1300	150	1050
DW1350-C900/MPEW- <input checked="" type="checkbox"/>	57.09		1450	450	900
DW1350-C1050/MPEW- <input checked="" type="checkbox"/>	57.09		1450	300	1050
DW750-C600/SCSC- <input checked="" type="checkbox"/>	33.46		850	150	600
DW900-C600/SCSC- <input checked="" type="checkbox"/>	39.37		1000	300	600
DW900-C750/SCSC- <input checked="" type="checkbox"/>	39.37		1000	150	750

MI Housing		44.96" wide x 28.54" deep (1142mm W x 725mm D)			
Part No.	Inches	Cabinet Height		Top Drawers	Bottom Drawers
		Inches	MM's	Available Points	Available Points
MI750-C450/NWSC- <input checked="" type="checkbox"/>	33.46		850	300	450
MI750-C600/NWSC- <input checked="" type="checkbox"/>	33.46		850	150	600
MI900-C600/NWSC- <input checked="" type="checkbox"/>	39.37		1000	300	600
MI900-C750/NWSC- <input checked="" type="checkbox"/>	39.37		1000	150	750
MI1050-C750/NWSC- <input checked="" type="checkbox"/>	45.28		1150	300	750
MI1050-C900/NWSC- <input checked="" type="checkbox"/>	45.28		1150	150	900
MI1200-C900/NWSC- <input checked="" type="checkbox"/>	51.18		1300	300	900
MI1200-C1050/NWSC- <input checked="" type="checkbox"/>	51.18		1300	150	1050
MI1350-C900/NWSC- <input checked="" type="checkbox"/>	57.09		1450	450	900
MI1350-C1050/NWSC- <input checked="" type="checkbox"/>	57.09		1450	300	1050

DW/MI Full Width Drawers					
Height (Points)	Usable Height	Sidewall Height	DW 440lb (200kg)	MI 440lb (200kg)	
75	2.17" (55mm)	1.97" (50mm)	DW75F-C/MPEW	MI75F-C/NWSC	
100	3.15" (80mm)	3.03" (77mm)	DW100F-C/MPEW	MI100F-C/NWSC	
125	4.13" (105mm)	3.03" (77mm)	DW125F-C/MPEW	MI125F-C/NWSC	
150	5.12" (130mm)	5" (127mm)	DW150F-C/MPEW	MI150F-C/NWSC	
175	6.1" (155mm)	5" (127mm)	DW175F-C/MPEW	MI175F-C/NWSC	
200	7.09" (180mm)	6.97" (177mm)	DW200F-C/MPEW	MI200F-C/NWSC	
225	8.07" (205mm)	6.97" (177mm)	DW225F-C/MPEW	MI225F-C/NWSC	
300	11.02" (280mm)	10.91" (277mm)	DW300F-C/MPEW	MI300F-C/NWSC	
75	2.17" (55mm)	1.97" (50mm)	DW75F-C/SCSC		
100	3.15" (80mm)	3.03" (77mm)	DW100F-C/SCSC		
125	4.13" (105mm)	3.03" (77mm)	DW125F-C/SCSC		
150	5.12" (130mm)	5" (127mm)	DW150F-C/SCSC		
175	6.1" (155mm)	5" (127mm)	DW175F-C/SCSC		
200	7.09" (180mm)	6.97" (177mm)	DW200F-C/SCSC		
225	8.07" (205mm)	6.97" (177mm)	DW225F-C/SCSC		
300	11.02" (280mm)	10.91" (277mm)	DW300F-C/SCSC		

Drawer for lower section see pages 88-89.



■ Select: Lock □ Select: Color

See pages 82-90 for details.

HT/CLES Combination

Cabinet Housing

CLES has CL drawers with a usable width of 18" on bottom left and ES drawers with a usable width of 30" on bottom right. Housing accepts HT tops and bases.



ML/NSST Combination

Cabinet Housing

45" wide x 22 1/2" deep - ML top drawers have a usable width of 40 13/16". NSST has NS drawers with a usable width of 12 1/16" on bottom left and ST drawers with a usable width of 24" on bottom right. Housing accepts ML tops and bases.



HT Housing 56.34" wide x 22.52" deep (1431mm W x 572mm D)

Part No.	Cabinet Height		Top Drawers	Bottom Drawers
	Inches	MM's	Available Points	Available Points
HT750-C450/CLES-■□	33.46	850	300	450
HT750-C600/CLES-■□	33.46	850	150	600
HT900-C600/CLES-■□	39.37	1000	300	600
HT900-C750/CLES-■□	39.37	1000	150	750
HT1050-C750/CLES-■□	45.28	1150	300	750
HT1050-C900/CLES-■□	45.28	1150	150	900
HT1200-C900/CLES-■□	51.18	1300	300	900
HT1200-C1050/CLES-■□	51.18	1300	150	1050
HT1350-C900/CLES-■□	57.09	1450	450	900
HT1350-C1050/CLES-■□	57.09	1450	300	1050

ML Housing 44.96" wide x 22.52" deep (1142mm W x 572mm D)

Part No.	Cabinet Height		Top Drawers	Bottom Drawers
	Inches	MM's	Available Points	Available Points
ML750-C450/NSST-■□	33.46	850	300	450
ML750-C600/NSST-■□	33.46	850	150	600
ML900-C600/NSST-■□	39.37	1000	300	600
ML900-C750/NSST-■□	39.37	1000	150	750
ML1050-C750/NSST-■□	45.28	1150	300	750
ML1050-C900/NSST-■□	45.28	1150	150	900
ML1200-C900/NSST-■□	51.18	1300	300	900
ML1200-C1050/NSST-■□	51.18	1300	150	1050
ML1350-C900/NSST-■□	57.09	1450	450	900
ML1350-C1050/NSST-■□	57.09	1450	300	1050

HT/ML Full Width Drawers

Height (Points)	Usable Height	Sidewall Height	HT 440lb (200kg)	ML 440lb (200kg)
75	2.17" (55mm)	1.97" (50mm)	HT75F-C/CLE	ML75F-C/NSST
100	3.15" (80mm)	3.03" (77mm)	HT100F-C/CLES	ML100F-C/NSST
125	4.13" (105mm)	3.03" (77mm)	HT125F-C/CLES	ML125F-C/NSST
150	5.12" (130mm)	5" (127mm)	HT150F-C/CLES	ML150F-C/NSST
175	6.1" (155mm)	5" (127mm)	HT175F-C/CLES	ML175F-C/NSST
200	7.09" (180mm)	6.97" (177mm)	HT200F-C/CLES	ML200F-C/NSST
225	8.07" (205mm)	6.97" (177mm)	HT225F-C/CLES	ML225F-C/NSST
300	11.02" (280mm)	10.91" (277mm)	HT300F-C/CLES	ML300F-C/NSST

Drawer for lower section see pages 88-89.



When you need storage plus mobility, Lista mobile storage cabinets, work centers and toolboxes provide safe and secure storage and transport for parts and tools. Almost any Lista cabinet can be mounted on a mobile base to allow for maximum flexibility and versatility. Each mobile workstation can be designed to exactly suit your specific needs.

By combining a pair of housings in one mobile work center, your storage options multiply even further.

For specific mobile accessories, see pages 108–109.



Lista mobile cabinets provide a diverse array of storage options:

- Can be combined in side-by-side configurations
- A wide variety of modular components and accessories
- A variety of worksurfaces
- Available with Lista's Nexus Accessory System (see Lista's Workbench)

Each mobile cabinet comes with:

- 4 heavy-duty casters (2 fixed and 2 swivel with wheel locks)
- Handle(s)
- Cylinder lock and 2 keys
- Individual drawer latches (IDL)
- The patented PreventTip® safety system (prevents cabinets from tipping by ensuring that when one drawer is open, all others are securely closed)

MODEL 600 SHALLOW DEPTH MOBILE CABINET COMBINATIONS (22.5" DEEP X 35.66" HIGH *NS = 32.3" HIGH, CL = 33.2" HIGH)

■ Select: Lock □ Select: Color

See page 40 for details.

	Cabinet Width	NS-16.85" Wide	CL-22.20" Wide	ST-28.23" Wide
 <p>0600-0402</p>	Drawer Capacities	165 lbs. (75kg)	440 lbs. (200kg)	440 lbs. (200kg)
	Drawers Usable Ht. (Points)	NS	CL	ST
	3" (75mm)	NSDR105-100	CLDR209-100	SDR316-100
	5" (125mm)	NSDR105-150	CLDR206-150	SDR209-150
5" (125mm)	NSDR105-150	CLDR206-150	SDR104-150	
7" (175mm)	NSDR104-200	CLDR104-200	SDR104-200	
Cabinets				
Without interiors	NS0600-0402N-M- <input type="checkbox"/>	CL0600-0402F-M- <input type="checkbox"/>	ST0600-0402F-M- <input type="checkbox"/>	
With Interiors	NS0600-0402NA-M- <input type="checkbox"/>	CL0600-0402FA-M- <input type="checkbox"/>	ST0600-0402FA-M- <input type="checkbox"/>	
 <p>0600-0501</p>	Drawers Usable Ht. (Points)	NS	CL	ST
	2" (50mm)	NSDR105-75	CLDR312-75	SDR518-75
	2" (50mm)	NSDR105-75	CLDR312-75	SDR308-75
	3" (75mm)	NSDR105-100	CLDR209-100	SDR308-100
5" (125mm)	NSDR105-150	CLDR206-150	SDR206-150	
7" (175mm)	NSDR104-200	CLDR104-200	SDR206-200	
Cabinets				
Without interiors	NS0600-0501N-M- <input type="checkbox"/>	CL0600-0501F-M- <input type="checkbox"/>	ST0600-0501F-M- <input type="checkbox"/>	
With Interiors	NS0600-0501NA-M- <input type="checkbox"/>	CL0600-0501FA-M- <input type="checkbox"/>	ST0600-0501FA-M- <input type="checkbox"/>	
 <p>0600-0502</p>	Drawers Usable Ht. (Points)	NS	CL	ST
	3" (75mm)	NSDR012-100	CLDR209-100	SDR316-100
	3" (75mm)	NSDR104-100	CLDR209-100	SDR209-100
	3" (75mm)	NSDR104-100	CLDR209-100	SDR209-100
5" (125mm)	NSDR206-150	CLDR206-150	SDR104-150	
5" (125mm)	NSDR209-150	CLDR206-150	SDR104-150	
Cabinets				
Without interiors	NS0600-0502N-M- <input type="checkbox"/>	CL0600-0502F-M- <input type="checkbox"/>	ST0600-0502F-M- <input type="checkbox"/>	
With Interiors	NS0600-0502NA-M- <input type="checkbox"/>	CL0600-0502FA-M- <input type="checkbox"/>	ST0600-0502FA-M- <input type="checkbox"/>	
 <p>0600-0601</p>	Drawers Usable Ht. (Points)	NS	CL	ST
	2" (50mm)	NSDR024-75	CLDR312-75	SDR308-75
	2" (50mm)	NSDR006-75	CLDR312-75	SDR420-75
	3" (75mm)	NSDR105-100	CLDR209-100	SDR420-100
3" (75mm)	NSDR105-100	CLDR209-100	SDR209-100	
3" (75mm)	NSDR104-100	CLDR209-100	SDR209-100	
5" (125mm)	NSDR102-150	CLDR206-150	SDR104-150	
Cabinets				
Without interiors	NS0600-0601N-M- <input type="checkbox"/>	CL0600-0601F-M- <input type="checkbox"/>	ST0600-0601F-M- <input type="checkbox"/>	
With Interiors	NS0600-0601NA-M- <input type="checkbox"/>	CL0600-0601FA-M- <input type="checkbox"/>	ST0600-0601FA-M- <input type="checkbox"/>	

ES—34.25" Wide	HS—40.28" Wide	MS—46.97" Wide	HT—56.34" Wide
440 lbs. (200kg)	440 lbs. (200kg)	440 lbs. (200kg)	440 lbs. (200kg)
ES	HS	MS	HT
ESDR-LR312-100 ESDR-LR209-150 ESDR-LR207-150 ESDR207-200	HDR621-100 HDR312-150 HDR312-150 HDR206-200	MSDR415-100 MSDR312-150 MSDR312-150 MSDR-LR209-200	HTDR-LR312-100 HTDR-LR209-150 HTDR-LR209-150 HTDR-LR106-200
ES0600-0402F-M- <input type="checkbox"/> ES0600-0402FA-M- <input type="checkbox"/>	HS0600-0402F-M- <input type="checkbox"/> HS0600-0402FA-M- <input type="checkbox"/>	MS0600-0402F-M- <input type="checkbox"/> MS0600-0402FA-M- <input type="checkbox"/>	HT0600-0402F-M- <input type="checkbox"/> HT0600-0402FA-M- <input type="checkbox"/>
ES	HS	MS	HT
ESDR621-75 ESDR-LR209-75 ESDR518-100 ESDR312-150 ESDR-LR207-200	HDR617-75 HDR-LR312-75 HDR518-100 HDR312-150 HDR-LR106-200	MSDR-LR312-75 MSDR-LR312-75 MSDR-LR210-100 MSDR-LR207-150 MSDR207-200	HTDR518-75 HTDR-LR415-75 HTDR-LR312-100 HTDR-LR209-150 HTDR-LR106-200
ES0600-0501F-M- <input type="checkbox"/> ES0600-0501FA-M- <input type="checkbox"/>	HS0600-0501F-M- <input type="checkbox"/> HS0600-0501FA-M- <input type="checkbox"/>	MS0600-0501F-M- <input type="checkbox"/> MS0600-0501FA-M- <input type="checkbox"/>	HT0600-0501F-M- <input type="checkbox"/> HT0600-0501FA-M- <input type="checkbox"/>
ES	HS	MS	HT
ESDR-LR312-100 ESDR-LR309-100 ESDR-LR207-100 ESDR207-150 ESDR207-150	HDR617-100 HDR415-100 HDR-LR207-100 HDR206-150 HDR206-150	MSDR312-100 MSDR312-100 MSDR312-100 MSDR207-150 MSDR207-150	HTDR-LR312-100 HTDR-LR312-100 HTDR-LR312-100 HTDR-LR209-150 HTDR-LR106-150
ES0600-0502F-M- <input type="checkbox"/> ES0600-0502FA-M- <input type="checkbox"/>	HS0600-0502F-M- <input type="checkbox"/> HS0600-0502FA-M- <input type="checkbox"/>	MS0600-0502F-M- <input type="checkbox"/> MS0600-0502FA-M- <input type="checkbox"/>	HT0600-0502F-M- <input type="checkbox"/> HT0600-0502FA-M- <input type="checkbox"/>
ES	HS	MS	HT
ESDR310-75 ESDR310-75 ESDR207-100 ESDR207-100 ESDR207-100 ESDR-LR209-150	HDR518-75 HDR-LR312-75 HDR312-100 HDR312-100 HDR312-100 HDR206-150	MSDR518-75 MSDR415-75 MSDR415-100 MSDR312-100 MSDR312-100 MSDR207-150	HTDR-LR209-75 HTDR-LR415-75 HTDR-LR415-100 HTDR-LR312-100 HTDR-LR312-100 HTDR-LR209-150
ES0600-0601F-M- <input type="checkbox"/> ES0600-0601FA-M- <input type="checkbox"/>	HS0600-0601F-M- <input type="checkbox"/> HS0600-0601FA-M- <input type="checkbox"/>	MS0600-0601F-M- <input type="checkbox"/> MS0600-0601FA-M- <input type="checkbox"/>	HT0600-0601F-M- <input type="checkbox"/> HT0600-0601FA-M- <input type="checkbox"/>

MODEL 750 SHALLOW DEPTH MOBILE CABINET COMBINATIONS (22.5" DEEP X 41.57" HIGH *NS = 38.2" HIGH, CL = 39.1" HIGH)

■ Select: Lock □ Select: Color

See page 40 for details.

	Cabinet Width	NS-16.85" Wide	CL-22.20" Wide	ST-28.23" Wide
 <p>0750-0505</p>	Drawer Capacities	165 lbs. (75kg)	440 lbs. (200kg)	440 lbs. (200kg)
	Drawers Usable Ht. (Points)	NS	CL	ST
	2.17" (75mm)	NSDR105-75	CLDR312-75	SDR518-75
	3.15" (100mm)	NSDR105-100	CLDR209-100	SDR308-100
	4.13" (125mm)	NSDR105-100	CLDR209-100	SDR308-100
	7.09" (200mm)	NSDR104-200	CLDR104-200	SDR206-200
	9.06" (250mm)	NSDR104-250	CLDR104-250	SDR104-250
	Cabinets			
	Without interiors	NS0750-0505N-M- <input type="checkbox"/>	CL0750-0505F-M- <input type="checkbox"/>	ST0750-0505F-M- <input type="checkbox"/>
	With Interiors	NS0750-0505NA-M- <input type="checkbox"/>	CL0750-0505FA-M- <input type="checkbox"/>	ST0750-0505FA-M- <input type="checkbox"/>
 <p>0750-0602</p>	Drawers Usable Ht. (Points)	NS	CL	ST
	2.17" (75mm)	NSDR209-75	CLDR312-75	SDR518-75
	2.17" (75mm)	NSDR209-75	CLDR312-75	SDR518-75
	3.15" (100mm)	NSDR106-100	CLDR209-100	SDR308-100
	3.15" (100mm)	NSDR104-100	CLDR209-100	SDR308-100
	5.12" (150mm)	NSDR105-150	CLDR206-150	SDR206-150
	9.06" (250mm)	NSDR102-250	CLDR104-250	SDR104-250
	Cabinets			
	Without interiors	NS0750-0602N-M- <input type="checkbox"/>	CL0750-0602F-M- <input type="checkbox"/>	ST0750-0602F-M- <input type="checkbox"/>
	With Interiors	NS0750-0602NA-M- <input type="checkbox"/>	CL0750-0602FA-M- <input type="checkbox"/>	ST0750-0602FA-M- <input type="checkbox"/>
 <p>0750-0701</p>	Drawers Usable Ht. (Points)	NS	CL	ST
	2.17" (75mm)	NSDR063-75	CLDR312-75	SDR518-75
	2.17" (75mm)	NSDR006-75	CLDR312-75	SDR518-75
	2.17" (75mm)	NSDR105-75	CLDR312-75	SDR308-75
	2.17" (75mm)	NSDR102-75	CLDR312-75	SDR308-75
	3.15" (100mm)	NSDR104-100	CLDR209-100	SDR308-100
	5.12" (150mm)	NSDR104-150	CLDR206-150	SDR206-150
	7.09" (200mm)	NSDR106-200	CLDR104-200	SDR206-200
	Cabinets			
	Without interiors	NS0750-0701N-M- <input type="checkbox"/>	CL0750-0701F-M- <input type="checkbox"/>	ST0750-0701F-M- <input type="checkbox"/>
	With Interiors	NS0750-0701NA-M- <input type="checkbox"/>	CL0750-0701FA-M- <input type="checkbox"/>	ST0750-0701FA-M- <input type="checkbox"/>
 <p>0750-0801</p>	Drawers Usable Ht. (Points)	NS	CL	ST
	2.17" (75mm)	NSDR062-75	CLDR021-75	SDR160-75
	2.17" (75mm)	NSDR014-75	CLDR018-75	SDR032-75
	2.17" (75mm)	NSDR104-75	CLDR012-75	SDR012-75
	2.17" (75mm)	NSDR105-75	CLDR009-75	SDR518-75
	3.15" (100mm)	NSDR104-100	CLDR209-100	SDR420-100
	3.15" (100mm)	NSDR104-100	CLDR206-100	SDR316-100
	3.15" (100mm)	NSDR104-100	CLDR206-100	SDR308-100
	5.12" (150mm)	NSDR105-150	CLDR104-150	SDR106-150
	Cabinets			
	Without interiors	NS0750-0801N-M- <input type="checkbox"/>	CL0750-0801F-M- <input type="checkbox"/>	ST0750-0801F-M- <input type="checkbox"/>
	With Interiors	NS0750-0801NA-M- <input type="checkbox"/>	CL0750-0801FA-M- <input type="checkbox"/>	ST0750-0801FA-M- <input type="checkbox"/>

ES—34.25" Wide	HS—40.28" Wide	MS—46.97" Wide	HT—56.34" Wide
440 lbs. (200kg)	440 lbs. (200kg)	440 lbs. (200kg)	440 lbs. (200kg)
ES	HS	MS	HT
ESDR518-75 ESDR-LR312-100 ESDR312-100 ESDR209-200 ESDR209-250	HDR518-75 HDR-LR312-100 HDR312-100 HDR206-200 HDR206-250	MSDR-LR312-75 MSDR-LR312-100 MSDR-LR312-100 MSDR-LR210-200 MSDR-LR210-250	HTDR-LR312-75 HTDR-LR312-100 HTDR-LR312-100 HTDR-LR209-200 HTDR-LR209-250
ES0750-0505F-M- <input type="checkbox"/> ES0750-0505FA-M- <input type="checkbox"/>	HS0750-0505F-M- <input type="checkbox"/> HS0750-0505FA-M- <input type="checkbox"/>	MS0750-0505F-M- <input type="checkbox"/> MS0750-0505FA-M- <input type="checkbox"/>	HT0750-0505F-M- <input type="checkbox"/> HT0750-0505FA-M- <input type="checkbox"/>
ES	HS	MS	HT
ESDR621-75 ESDR-LR312-75 ESDR518-100 ESDR-LR209-100 ESDR312-150 ESDR207-250	HDR617-75 HDR-LR312-75 HDR518-100 HDR-LR209-100 HDR312-150 HDR-LR106-250	MSDR724-75 MSDR-LR312-75 MSDR621-100 MSDR-LR210-100 MSDR415-150 MSDR-LR209-250	HTDR827-75 HTDR-LR312-75 HTDR724-100 HTDR-LR209-100 HTDR518-150 HTDR-LR209-250
ES0750-0602F-M- <input type="checkbox"/> ES0750-0602FA-M- <input type="checkbox"/>	HS0750-0602F-M- <input type="checkbox"/> HS0750-0602FA-M- <input type="checkbox"/>	MS0750-0602F-M- <input type="checkbox"/> MS0750-0602FA-M- <input type="checkbox"/>	HT0750-0602F-M- <input type="checkbox"/> HT0750-0602FA-M- <input type="checkbox"/>
ES	HS	MS	HT
ESDR518-75 ESDR518-75 ESDR-LR207-75 ESDR-LR207-75 ESDR415-100 ESDR310-150 ESDR-LR209-200	HDR617-75 HDR617-75 HDR-LR312-75 HDR-LR312-75 HDR518-100 HDR312-150 HDR-LR106-200	MSDR724-75 MSDR724-75 MSDR-LR312-75 MSDR-LR312-75 MSDR621-100 MSDR415-150 MSDR-LR209-200	HTDR827-75 HTDR827-75 HTDR-LR312-75 HTDR-LR312-75 HTDR724-100 HTDR518-150 HTDR-LR106-200
ES0750-0701F-M- <input type="checkbox"/> ES0750-0701FA-M- <input type="checkbox"/>	HS0750-0701F-M- <input type="checkbox"/> HS0750-0701FA-M- <input type="checkbox"/>	MS0750-0701F-M- <input type="checkbox"/> MS0750-0701FA-M- <input type="checkbox"/>	HT0750-0701F-M- <input type="checkbox"/> HT0750-0701FA-M- <input type="checkbox"/>
ES	HS	MS	HT
ESDR045-75 ESDR-LR312-75 ESDR-LR312-75 ESDR-LR207-75 ESDR310-100 ESDR310-100 ESDR207-100 ESDR207-150	HDR621-75 HDR621-75 HDR518-75 HDR518-75 HDR415-100 HDR415-100 HDR415-100 HDR206-150	MSDR415-75 MSDR415-75 MSDR312-75 MSDR312-75 MSDR-LR210-100 MSDR-LR210-100 MSDR-LR210-100 MSDR-LR209-150	HTDR-LR415-75 HTDR-LR415-75 HTDR-LR312-75 HTDR-LR312-75 HTDR-LR209-100 HTDR-LR209-100 HTDR-LR209-100 HTDR-LR106-150
ES0750-0801F-M- <input type="checkbox"/> ES0750-0801FA-M- <input type="checkbox"/>	HS0750-0801F-M- <input type="checkbox"/> HS0750-0801FA-M- <input type="checkbox"/>	MS0750-0801F-M- <input type="checkbox"/> MS0750-0801FA-M- <input type="checkbox"/>	HT0750-0801F-M- <input type="checkbox"/> HT0750-0801FA-M- <input type="checkbox"/>

MODEL 900 SHALLOW DEPTH MOBILE CABINET COMBINATIONS (22.5" DEEP X 47.47 HIGH *NS = 44.1" HIGH, CL = 45" HIGH)

■ Select: Lock □ Select: Color

See page 40 for details.

	Cabinet Width	NS-16.85" Wide	CL-22.20" Wide	ST-28.23" Wide
 <p>2" 3" 4" 5" 7" 9"</p> <p>0900-0603</p>	Drawer Capacities	165 lbs. (75kg)	440 lbs. (200kg)	440 lbs. (200kg)
	Drawers Usable Ht. (Points)	NS	CL	ST
	2.17" (75mm)	NSDR012-75	CLDR312-75	SDR518-75
	3.15" (100mm)	NSDR209-100	CLDR209-100	SDR308-100
	4.13" (125mm)	NSDR104-100	CLDR209-100	SDR308-100
	5.12" (150mm)	NSDR206-150	CLDR206-150	SDR206-150
	7.09" (200mm)	NSDR209-200	CLDR104-200	SDR206-200
	9.06" (250mm)	NSDR104-250	CLDR104-250	SDR104-250
	Cabinets			
	Without interiors	NS0900-0603N-M- <input type="checkbox"/>	CL0900-0603F-M- <input type="checkbox"/>	ST0900-0603F-M- <input type="checkbox"/>
With Interiors	NS0900-0603NA-M- <input type="checkbox"/>	CL0900-0603FA-M- <input type="checkbox"/>	ST0900-0603FA-M- <input type="checkbox"/>	
 <p>3" 3" 3" 3" 5" 5" 7"</p> <p>0900-0702</p>	Drawers Usable Ht. (Points)	NS	CL	ST
	3.15" (100mm)	NSDR106-100	CLDR209-100	SDR316-100
	3.15" (100mm)	NSDR106-100	CLDR209-100	SDR316-100
	3.15" (100mm)	NSDR104-100	CLDR209-100	SDR209-100
	3.15" (100mm)	NSDR104-100	CLDR209-100	SDR209-100
	5.12" (150mm)	NSDR206-150	CLDR206-150	SDR206-150
	5.12" (150mm)	NSDR105-150	CLDR206-150	SDR206-150
	7.09" (200mm)	NSDR209-200	CLDR104-200	SDR104-200
	Cabinets			
	Without interiors	NS0900-0702N-M- <input type="checkbox"/>	CL0900-0702F-M- <input type="checkbox"/>	ST0900-0702F-M- <input type="checkbox"/>
With Interiors	NS0900-0702NA-M- <input type="checkbox"/>	CL0900-0702FA-M- <input type="checkbox"/>	ST0900-0702FA-M- <input type="checkbox"/>	
 <p>2" 2" 3" 3" 3" 5" 5" 5"</p> <p>0900-0802</p>	Drawers Usable Ht. (Points)	NS	CL	ST
	2.17" (75mm)	NSDR012-75	CLDR312-75	SDR420-75
	2.17" (75mm)	NSDR012-75	CLDR312-75	SDR420-75
	3.15" (100mm)	NSDR209-100	CLDR209-100	SDR316-100
	3.15" (100mm)	NSDR209-100	CLDR209-100	SDR316-100
	3.15" (100mm)	NSDR209-100	CLDR209-100	SDR316-100
	5.12" (150mm)	NSDR104-150	CLDR206-150	SDR209-150
	5.12" (150mm)	NSDR104-150	CLDR206-150	SDR209-150
	5.12" (150mm)	NSDR104-150	CLDR206-150	SDR209-150
	Cabinets			
Without interiors	NS0900-0802N-M- <input type="checkbox"/>	CL0900-0802F-M- <input type="checkbox"/>	ST0900-0802F-M- <input type="checkbox"/>	
With Interiors	NS0900-0802NA-M- <input type="checkbox"/>	CL0900-0802FA-M- <input type="checkbox"/>	ST0900-0802FA-M- <input type="checkbox"/>	
 <p>2" 2" 2" 3" 3" 3" 5" 5"</p> <p>0900-0901</p>	Drawers Usable Ht. (Points)	NS	CL	ST
	2.17" (75mm)	NSDR020-75	CLDR018-75	SDR420-75
	2.17" (75mm)	NSDR008-75	CLDR009-75	SDR420-75
	2.17" (75mm)	NSDR006-75	CLDR420-75	SDR316-75
	2.17" (75mm)	NSDR006-75	CLDR415-75	SDR316-75
	3.15" (100mm)	NSDR206-100	CLDR312-100	SDR316-100
	3.15" (100mm)	NSDR105-100	CLDR312-100	SDR209-100
	3.15" (100mm)	NSDR105-100	CLDR312-100	SDR206-100
	5.12" (150mm)	NSDR104-150	CLDR104-150	SDR206-150
	5.12" (150mm)	NSDR104-150	CLDR104-150	SDR104-150
Cabinets				
Without interiors	NS0900-0901N-M- <input type="checkbox"/>	CL0900-0901F-M- <input type="checkbox"/>	ST0900-0901F-M- <input type="checkbox"/>	
With Interiors	NS0900-0901NA-M- <input type="checkbox"/>	CL0900-0901FA-M- <input type="checkbox"/>	ST0900-0901FA-M- <input type="checkbox"/>	

ES-34.25" Wide	HS-40.28" Wide	MS-46.97" Wide	HT-56.34" Wide
440 lbs. (200kg)	440 lbs. (200kg)	440 lbs. (200kg)	440 lbs. (200kg)
ES	HS	MS	HT
ESDR518-75 ESDR518-100 ESDR415-100 ESDR415-150 ESDR312-200 ESDR209-250	HDR518-75 HDR518-100 HDR415-100 HDR415-150 HDR312-200 HDR206-250	MSDR724-75 MSDR621-100 MSDR518-100 MSDR415-150 MSDR312-200 MSDR-LR210-250	HTDR724-75 HTDR621-100 HTDR-LR209-100 HTDR415-150 HTDR410-200 HTDR-LR209-250
ES0900-0603F-M- <input type="checkbox"/> ES0900-0603FA-M- <input type="checkbox"/>	HS0900-0603F-M- <input type="checkbox"/> HS0900-0603FA-M- <input type="checkbox"/>	MS0900-0603F-M- <input type="checkbox"/> MS0900-0603FA-M- <input type="checkbox"/>	HT0900-0603F-M- <input type="checkbox"/> HT0900-0603FA-M- <input type="checkbox"/>
ES	HS	MS	HT
ESDR518-100 ESDR518-100 ESDR415-100 ESDR415-100 ESDR312-150 ESDR312-150 ESDR209-200	HDR518-100 HDR518-100 HDR415-100 HDR415-100 HDR312-150 HDR312-150 HDR206-200	MSDR621-100 MSDR621-100 MSDR518-100 MSDR518-100 MSDR415-150 MSDR415-150 MSDR312-200	HTDR724-100 HTDR724-100 HTDR621-100 HTDR621-100 HTDR518-150 HTDR518-150 HTDR410-200
ES0900-0702F-M- <input type="checkbox"/> ES0900-0702FA-M- <input type="checkbox"/>	HS0900-0702F-M- <input type="checkbox"/> HS0900-0702FA-M- <input type="checkbox"/>	MS0900-0702F-M- <input type="checkbox"/> MS0900-0702FA-M- <input type="checkbox"/>	HT0900-0702F-M- <input type="checkbox"/> HT0900-0702FA-M- <input type="checkbox"/>
ES	HS	MS	HT
ESDR518-75 ESDR518-75 ESDR415-100 ESDR415-100 ESDR415-100 ESDR415-100 ESDR312-150 ESDR312-150 ESDR312-150	HDR518-75 HDR518-75 HDR415-100 HDR415-100 HDR415-100 HDR415-100 HDR312-150 HDR312-150 HDR312-150	MSDR724-75 MSDR724-75 MSDR621-100 MSDR621-100 MSDR621-100 MSDR621-100 MSDR312-150 MSDR312-150 MSDR312-150	HTDR724-75 HTDR724-75 HTDR621-100 HTDR621-100 HTDR621-100 HTDR621-100 HTDR-LR312-150 HTDR-LR312-150 HTDR-LR312-150
ES0900-0802F-M- <input type="checkbox"/> ES0900-0802FA-M- <input type="checkbox"/>	HS0900-0802F-M- <input type="checkbox"/> HS0900-0802FA-M- <input type="checkbox"/>	MS0900-0802F-M- <input type="checkbox"/> MS0900-0802FA-M- <input type="checkbox"/>	HT0900-0802F-M- <input type="checkbox"/> HT0900-0802FA-M- <input type="checkbox"/>
ES	HS	MS	HT
ESDR415-75 ESDR415-75 ESDR312-75 ESDR312-75 ESDR312-100 ESDR209-100 ESDR209-100 ESDR-LR209-150 ESDR-LR209-150	HDR518-75 HDR518-75 HDR415-75 HDR415-75 HDR415-100 HDR312-100 HDR312-100 HDR206-150 HDR206-150	MSDR624-75 MSDR624-75 MSDR518-75 MSDR518-75 MSDR518-100 MSDR415-100 MSDR415-100 MSDR-LR209-150 MSDR-LR209-150	HTDR621-75 HTDR621-75 HTDR518-75 HTDR518-75 HTDR518-100 HTDR410-100 HTDR410-100 HTDR-LR209-150 HTDR-LR209-150
ES0900-0901F-M- <input type="checkbox"/> ES0900-0901FA-M- <input type="checkbox"/>	HS0900-0901F-M- <input type="checkbox"/> HS0900-0901FA-M- <input type="checkbox"/>	MS0900-0901F-M- <input type="checkbox"/> MS0900-0901FA-M- <input type="checkbox"/>	HT0900-0901F-M- <input type="checkbox"/> HT0900-0901FA-M- <input type="checkbox"/>

MODEL 600 FULL DEPTH MOBILE CABINET COMBINATIONS (28.5" DEEP X 35.66" HIGH *NW = 32.3" HIGH)

■ Select: Lock □ Select: Color

See page 40 for details.

	Cabinet Width	NW-16.85" Wide	MP-22.20" Wide	SC-28.23" Wide
 0600-0402	Drawer Capacities	165 lbs. (75kg)	440 lbs. (200kg)	440 lbs. (200kg)
	Drawers Usable Ht. (Points)	NW	MP	SC
	3" (75mm)	NWDR212-100	MPDR316-100	DR420-100
	5" (125mm)	NWDR104-150	MPDR209-150	DR316-150
	5" (125mm)	NWDR104-150	MPDR104-150	DR316-150
	7" (175mm)	NWDR104-200	MPDR104-200	DR209-200
	Cabinets			
	Without interiors	NW0600-0402N-M- <input type="checkbox"/>	MP0600-0402F-M- <input type="checkbox"/>	SC0600-0402F-M- <input type="checkbox"/>
	With Interiors	NW0600-0402NA-M- <input type="checkbox"/>	MP0600-0402FA-M- <input type="checkbox"/>	SC0600-0402FA-M- <input type="checkbox"/>
 0600-0501	Drawers Usable Ht. (Points)	NW	MP	SC
	2" (50mm)	NWDR018-75	MPDR316-75	DR420-75
	2" (50mm)	NWDR212-75	MPDR316-75	DR316-75
	3" (75mm)	NWDR212-100	MPDR209-100	DR316-100
	5" (125mm)	NWDR104-150	MPDR104-150	DR209-150
	7" (175mm)	NWDR104-200	MPDR104-200	DR209-200
	Cabinets			
	Without interiors	NW0600-0501N-M- <input type="checkbox"/>	MP0600-0501F-M- <input type="checkbox"/>	SC0600-0501F-M- <input type="checkbox"/>
	With Interiors	NW0600-0501NA-M- <input type="checkbox"/>	MP0600-0501FA-M- <input type="checkbox"/>	SC0600-0501FA-M- <input type="checkbox"/>
 0600-0502	Drawers Usable Ht. (Points)	NW	MP	SC
	3" (75mm)	NWDR018-100	MPDR316-100	DR420-100
	3" (75mm)	NWDR212-100	MPDR209-100	DR420-100
	3" (75mm)	NWDR212-100	MPDR209-100	DR316-100
	5" (125mm)	NWDR107-150	MPDR104-150	DR316-150
	5" (125mm)	NWDR107-150	MPDR104-150	DR209-150
	Cabinets			
	Without interiors	NW0600-0502N-M- <input type="checkbox"/>	MP0600-0502F-M- <input type="checkbox"/>	SC0600-0502F-M- <input type="checkbox"/>
	With Interiors	NW0600-0502NA-M- <input type="checkbox"/>	MP0600-0502FA-M- <input type="checkbox"/>	SC0600-0502FA-M- <input type="checkbox"/>
 0600-0601	Drawers Usable Ht. (Points)	NW	MP	SC
	2" (50mm)	NWDR105-75	MPDR208-75	DR209-75
	2" (50mm)	NWDR212-75	MPDR316-75	DR420-75
	3" (75mm)	NWDR107-100	MPDR316-100	DR420-100
	3" (75mm)	NWDR107-100	MPDR209-100	DR316-100
	3" (75mm)	NWDR107-100	MPDR209-100	DR316-100
	5" (125mm)	NWDR104-150	MPDR104-150	DR209-150
	Cabinets			
	Without interiors	NW0600-0601N-M- <input type="checkbox"/>	MP0600-0601F-M- <input type="checkbox"/>	SC0600-0601F-M- <input type="checkbox"/>
	With Interiors	NW0600-0601NA-M- <input type="checkbox"/>	MP0600-0601FA-M- <input type="checkbox"/>	SC0600-0601FA-M- <input type="checkbox"/>

EW-34.25" Wide	HW-40.28" Wide	MW-46.97" Wide	DW-56.34" Wide
440 lbs. (200kg)	440 lbs. (200kg)	440 lbs. (200kg)	440 lbs. (200kg)
EW	HW	MW	DW
EWDR-LR312-100 EWDR-LR207-150 EWDR-LR207-150 EWDR207-200	HWDR628-100 HWDR312-150 HWDR312-150 HWDR206-200	MWDR-LR312-100 MWDR-LR209-150 MWDR-LR209-150 MWDR-LR106-200	DWDR-LR312-100 DWDR-LR209-150 DWDR-LR209-150 DWDR-LR106-200
EW0600-0402F-M- <input type="checkbox"/> EW0600-0402FA-M- <input type="checkbox"/>	HW0600-0402F-M- <input type="checkbox"/> HW0600-0402FA-M- <input type="checkbox"/>	MW0600-0402F-M- <input type="checkbox"/> MW0600-0402FA-M- <input type="checkbox"/>	DW0600-0402F-M- <input type="checkbox"/> DW0600-0402FA-M- <input type="checkbox"/>
EW	HW	MW	DW
EWDR518-75 EWDR415-75 EWDR415-100 EWDR212-150 EWDR212-200	HWDR628-75 HWDR-LR312-75 HWDR524-100 HWDR312-150 HWDR-LR106-200	MWDR-LR415-75 MWDR-LR415-75 MWDR-LR312-100 MWDR-LR209-150 MWDR-LR106-200	DWDR-LR518-75 DWDR-LR415-75 DWDR-LR312-100 DWDR-LR209-150 DWDR-LR106-200
EW0600-0501F-M- <input type="checkbox"/> EW0600-0501FA-M- <input type="checkbox"/>	HW0600-0501F-M- <input type="checkbox"/> HW0600-0501FA-M- <input type="checkbox"/>	MW0600-0501F-M- <input type="checkbox"/> MW0600-0501FA-M- <input type="checkbox"/>	DW0600-0501F-M- <input type="checkbox"/> DW0600-0501FA-M- <input type="checkbox"/>
EW	HW	MW	DW
EWDR-LR312-100 EWDR-LR312-100 EWDR-LR207-100 EWDR212-150 EWDR212-150	HWDR628-100 HWDR420-100 HWDR-LR209-100 HWDR209-150 HWDR209-150	MWDR-LR312-100 MWDR-LR312-100 MWDR-LR312-100 MWDR-LR209-150 MWDR-LR106-150	DWDR-LR312-100 DWDR-LR312-100 DWDR-LR312-100 DWDR-LR209-15 DWDR-LR106-150
EW0600-0502F-M- <input type="checkbox"/> EW0600-0502FA-M- <input type="checkbox"/>	HW0600-0502F-M- <input type="checkbox"/> HW0600-0502FA-M- <input type="checkbox"/>	MW0600-0502F-M- <input type="checkbox"/> MW0600-0502FA-M- <input type="checkbox"/>	DW0600-0502F-M- <input type="checkbox"/> DW0600-0502FA-M- <input type="checkbox"/>
EW	HW	MW	DW
EWDR310-75 EWDR310-75 EWDR207-100 EWDR207-100 EWDR207-100 EWDR104-150	HWDR524-75 HWDR-LR312-75 HWDR312-100 HWDR312-100 HWDR312-100 HWDR209-150	MWDR-LR209-75 MWDR-LR415-75 MWDR-LR415-100 MWDR-LR312-100 MWDR-LR312-100 MWDR-LR209-150	DWDR-LR209-75 DWDR-LR415-75 DWDR-LR415-100 DWDR-LR312-100 DWDR-LR312-100 DWDR-LR209-150
EW0600-0601F-M- <input type="checkbox"/> EW0600-0601FA-M- <input type="checkbox"/>	HW0600-0601F-M- <input type="checkbox"/> HW0600-0601FA-M- <input type="checkbox"/>	MW0600-0601F-M- <input type="checkbox"/> MW0600-0601FA-M- <input type="checkbox"/>	DW0600-0601F-M- <input type="checkbox"/> DW0600-0601FA-M- <input type="checkbox"/>

MODEL 750 FULL DEPTH MOBILE CABINET COMBINATIONS (28.5" DEEP X 41.57" HIGH *NW = 38.2" HIGH)

■ Select: Lock □ Select: Color

See page 40 for details.

	Cabinet Width Drawer Capacities	NW-16.85" Wide 165 lbs. (75kg)	MP-22.20" Wide 440 lbs. (200kg)	SC-28.23" Wide 440 lbs. (200kg)
 0750-0505	Drawers Usable Ht. (Points)	NW	MP	SC
	2.17" (75mm)	NWDR105-75	MPDR316-75	DR420-75
	3.15" (100mm)	NWDR105-100	MPDR209-100	DR316-100
	4.13" (125mm)	NWDR105-100	MPDR209-100	DR316-100
	7.09" (200mm)	NWDR104-200	MPDR206-200	DR312-200
	9.06" (250mm)	NWDR104-250	MPDR206-250	DR312-250
	Cabinets			
	Without interiors	NW0750-0505N-M- <input type="checkbox"/>	MP0750-0505F-M- <input type="checkbox"/>	SC0750-0505F-M- <input type="checkbox"/>
	With Interiors	NW0750-0505NA-M- <input type="checkbox"/>	MP0750-0505FA-M- <input type="checkbox"/>	SC0750-0505FA-M- <input type="checkbox"/>
 0750-0602	Drawers Usable Ht. (Points)	NW	MP	SC
	2.17" (75mm)	NWDR212-75	MPDR316-75	DR420-75
	2.17" (75mm)	NWDR212-75	MPDR316-75	DR420-75
	3.15" (100mm)	NWDR212-100	MPDR209-100	DR316-100
	3.15" (100mm)	NWDR107-100	MPDR209-100	DR316-100
	5.12" (150mm)	NWDR107-150	MPDR104-150	DR209-150
	9.06" (250mm)	NWDR104-250	MPDR104-250	DR209-250
	Cabinets			
	Without interiors	NW0750-0602N-M- <input type="checkbox"/>	MP0750-0602F-M- <input type="checkbox"/>	SC0750-0602F-M- <input type="checkbox"/>
	With Interiors	NW0750-0602NA-M- <input type="checkbox"/>	MP0750-0602FA-M- <input type="checkbox"/>	SC0750-0602FA-M- <input type="checkbox"/>
 0750-0701	Drawers Usable Ht. (Points)	NW	MP	SC
	2.17" (75mm)	NWDR212-75	MPDR316-75	DR036-75
	2.17" (75mm)	NWDR212-75	MPDR316-75	DR016-75
	2.17" (75mm)	NWDR107-75	MPDR316-75	DR524-75
	2.17" (75mm)	NWDR107-75	MPDR316-75	DR524-75
	3.15" (100mm)	NWDR107-100	MPDR209-100	DR420-100
	5.12" (150mm)	NWDR104-150	MPDR206-150	DR316-150
	7.09" (200mm)	NWDR104-200	MPDR104-200	DR209-200
	Cabinets			
	Without interiors	NW0750-0701N-M- <input type="checkbox"/>	MP0750-0701F-M- <input type="checkbox"/>	SC0750-0701F-M- <input type="checkbox"/>
	With Interiors	NW0750-0701NA-M- <input type="checkbox"/>	MP0750-0701FA-M- <input type="checkbox"/>	SC0750-0701FA-M- <input type="checkbox"/>
 0750-0801	Drawers Usable Ht. (Points)	NW	MP	SC
	2.17" (75mm)	NWDR212-75	MPDR028-75	DR036-75
	2.17" (75mm)	NWDR212-75	MPDR024-75	DR036-75
	2.17" (75mm)	NWDR107-75	MPDR018-75	DR420-75
	2.17" (75mm)	NWDR107-75	MPDR012-75	DR420-75
	3.15" (100mm)	NWDR104-100	MPDR104-100	DR316-100
	3.15" (100mm)	NWDR107-100	MPDR104-100	DR316-100
	3.15" (100mm)	NWDR107-100	MPDR104-100	DR209-100
	5.12" (150mm)	NWDR104-150	MPDR206-150	DR209-150
	Cabinets			
	Without interiors	NW0750-0801N-M- <input type="checkbox"/>	MP0750-0801F-M- <input type="checkbox"/>	SC0750-0801F-M- <input type="checkbox"/>
	With Interiors	NW0750-0801NA-M- <input type="checkbox"/>	MP0750-0801FA-M- <input type="checkbox"/>	SC0750-0801FA-M- <input type="checkbox"/>

EW-34.25" Wide 440 lbs. (200kg)	HW-40.28" Wide 440 lbs. (200kg)	MW-46.97" Wide 440 lbs. (200kg)	DW-56.34" Wide 440 lbs. (200kg)
EW EWDR518-75 EWDR-LR312-100 EWDR310-100 EWDR310-200 EWDR310-250	HW HWDR524-75 HWDR-LR312-100 HWDR312-100 HWDR209-200 HWDR209-250	MW MWDR628-75 MWDR-LR312-100 MWDR-LR312-100 MWDR-LR209-200 MWDR-LR209-250	DW DWDR-LR415-75 DWDR-LR415-100 DWDR-LR312-100 DWDR-LR312-200 DWDR-LR209-250
EW0750-0505F-M- <input type="checkbox"/> EW0750-0505FA-M- <input type="checkbox"/>	HW0750-0505F-M- <input type="checkbox"/> HW0750-0505FA-M- <input type="checkbox"/>	MW0750-0505F-M- <input type="checkbox"/> MW0750-0505FA-M- <input type="checkbox"/>	DW0750-0505F-M- <input type="checkbox"/> DW0750-0505FA-M- <input type="checkbox"/>
EW EWDR518-75 EWDR-LR312-75 EWDR415-100 EWDR-LR207-100 EWDR310-150 EWDR207-250	HW HWDR628-75 HWDR-LR312-75 HWDR524-100 HWDR-LR209-100 HWDR312-150 HWDR-LR106-250	MW MWDR732-75 MWDR-LR312-75 MWDR628-100 MWDR-LR209-100 MWDR420-150 MWDR203-250	DW DWDR836-75 DWDR-LR415-75 DWDR732-100 DWDR-LR312-100 DWDR524-150 DWDR203-250
EW0750-0602F-M- <input type="checkbox"/> EW0750-0602FA-M- <input type="checkbox"/>	HW0750-0602F-M- <input type="checkbox"/> HW0750-0602FA-M- <input type="checkbox"/>	MW0750-0602F-M- <input type="checkbox"/> MW0750-0602FA-M- <input type="checkbox"/>	DW0750-0602F-M- <input type="checkbox"/> DW0750-0602FA-M- <input type="checkbox"/>
EW EWDR518-75 EWDR518-75 EWDR-LR207-75 EWDR-LR207-75 EWDR415-100 EWDR310-150 EWDR-LR207-200	HW HWDR628-75 HWDR628-75 HWDR-LR312-75 HWDR-LR312-75 HWDR524-100 HWDR312-150 HWDR-LR106-200	MW MWDR732-75 MWDR732-75 MWDR-LR312-75 MWDR-LR312-75 MWDR628-100 MWDR420-150 MWDR-LR106-200	DW DWDR836-75 DWDR836-75 DWDR-LR415-75 DWDR-LR415-75 DWDR732-100 DWDR524-150 DWDR-LR106-200
EW0750-0701F-M- <input type="checkbox"/> EW0750-0701FA-M- <input type="checkbox"/>	HW0750-0701F-M- <input type="checkbox"/> HW0750-0701FA-M- <input type="checkbox"/>	MW0750-0701F-M- <input type="checkbox"/> MW0750-0701FA-M- <input type="checkbox"/>	DW0750-0701F-M- <input type="checkbox"/> DW0750-0701FA-M- <input type="checkbox"/>
EW EWDR040-75 EWDR-LR312-75 EWDR-LR312-75 EWDR-LR207-75 EWDR310-100 EWDR310-100 EWDR207-100 EWDR207-150	HW HWDR628-75 HWDR628-75 HWDR524-75 HWDR524-75 HWDR420-100 HWDR420-100 HWDR420-100 HWDR420-100 HWDR209-150	MW MWDR-LR518-75 MWDR-LR518-75 MWDR628-75 MWDR628-75 MWDR524-100 MWDR524-100 MWDR524-100 MWDR-LR209-150	DW DWDR-LR518-75 DWDR-LR518-75 DWDR-LR415-75 DWDR-LR415-75 DWDR-LR312-100 DWDR-LR312-100 DWDR-LR312-100 DWDR-LR209-150
EW0750-0801F-M- <input type="checkbox"/> EW0750-0801FA-M- <input type="checkbox"/>	HW0750-0801F-M- <input type="checkbox"/> HW0750-0801FA-M- <input type="checkbox"/>	MW0750-0801F-M- <input type="checkbox"/> MW0750-0801FA-M- <input type="checkbox"/>	DW0750-0801F-M- <input type="checkbox"/> DW0750-0801FA-M- <input type="checkbox"/>

MODEL 900 FULL DEPTH MOBILE CABINET COMBINATIONS (28.5" DEEP X 47.47" HIGH *NW = 44.1" HIGH)

■ Select: Lock □ Select: Color

See page 40 for details.

	Cabinet Width	NW-16.85" Wide	MP-22.20" Wide	SC-28.23" Wide
 <p>0900-0603</p>	Drawer Capacities	165 lbs. (75kg)	440 lbs. (200kg)	440 lbs. (200kg)
	Drawers Usable Ht. (Points)	NW	MP	SC
	2.17" (75mm)	NWDR107-75	MPDR018-75	DR420-75
	3.15" (100mm)	NWDR108-100	MPDR206-100	DR209-100
	4.13" (125mm)	NWDR108-100	MPDR206-100	DR209-100
	5.12" (150mm)	NWDR209-150	MPDR206-150	DR209-150
	7.09" (200mm)	NWDR104-200	MPDR206-200	DR209-200
	9.06" (250mm)	NWDR104-250	MPDR104-250	DR104-250
	Cabinets			
	Without interiors	NW0900-0603N-M- <input type="checkbox"/>	MP0900-0603F-M- <input type="checkbox"/>	SC0900-0603F-M- <input type="checkbox"/>
With Interiors	NW0900-0603NA-M- <input type="checkbox"/>	MP0900-0603FA-M- <input type="checkbox"/>	SC0900-0603FA-M- <input type="checkbox"/>	
 <p>0900-0702</p>	Drawers Usable Ht. (Points)	NW	MP	SC
	3.15" (100mm)	NWDR108-100	MPDR206-100	DR209-100
	3.15" (100mm)	NWDR108-100	MPDR206-100	DR209-100
	3.15" (100mm)	NWDR106-100	MPDR316-100	DR420-100
	3.15" (100mm)	NWDR106-100	MPDR316-100	DR420-100
	5.12" (150mm)	NWDR209-150	MPDR209-150	DR316-150
	5.12" (150mm)	NWDR209-150	MPDR209-150	DR316-150
	7.09" (200mm)	NWDR105-200	MPDR104-200	DR104-200
	Cabinets			
	Without interiors	NW0900-0702N-M- <input type="checkbox"/>	MP0900-0702F-M- <input type="checkbox"/>	SC0900-0702F-M- <input type="checkbox"/>
With Interiors	NW0900-0702NA-M- <input type="checkbox"/>	MP0900-0702FA-M- <input type="checkbox"/>	SC0900-0702FA-M- <input type="checkbox"/>	
 <p>0900-0802</p>	Drawers Usable Ht. (Points)	NW	MP	SC
	2.17" (75mm)	NWDR016-75	MPDR430-75	DR420-75
	2.17" (75mm)	NWDR016-75	MPDR430-75	DR420-75
	3.15" (100mm)	NWDR212-100	MPDR430-100	DR420-100
	3.15" (100mm)	NWDR212-100	MPDR430-100	DR420-100
	3.15" (100mm)	NWDR212-100	MPDR430-100	DR420-100
	5.12" (150mm)	NWDR104-150	MPDR312-150	DR316-150
	5.12" (150mm)	NWDR104-150	MPDR312-150	DR316-150
	5.12" (150mm)	NWDR104-150	MPDR312-150	DR316-150
	Cabinets			
Without interiors	NW0900-0802N-M- <input type="checkbox"/>	MP0900-0802F-M- <input type="checkbox"/>	SC0900-0802F-M- <input type="checkbox"/>	
With Interiors	NW0900-0802NA-M- <input type="checkbox"/>	MP0900-0802FA-M- <input type="checkbox"/>	SC0900-0802FA-M- <input type="checkbox"/>	
 <p>0900-0901</p>	Drawers Usable Ht. (Points)	NW	MP	SC
	2.17" (75mm)	NWDR018-75	MPDR510-75	DR524-75
	2.17" (75mm)	NWDR018-75	MPDR510-75	DR524-75
	2.17" (75mm)	NWDR212-75	MPDR316-75	DR420-75
	2.17" (75mm)	NWDR212-75	MPDR316-75	DR420-75
	3.15" (100mm)	NWDR107-100	MPDR209-100	DR316-100
	3.15" (100mm)	NWDR107-100	MPDR209-100	DR316-100
	3.15" (100mm)	NWDR107-100	MPDR209-100	DR316-100
	5.12" (150mm)	NWDR104-150	MPDR104-150	DR209-150
	5.12" (150mm)	NWDR104-150	MPDR104-150	DR209-150
Cabinets				
Without interiors	NW0900-0901N-M- <input type="checkbox"/>	MP0900-0901F-M- <input type="checkbox"/>	SC0900-0901F-M- <input type="checkbox"/>	
With Interiors	NW0900-0901NA-M- <input type="checkbox"/>	MP0900-0901FA-M- <input type="checkbox"/>	SC0900-0901FA-M- <input type="checkbox"/>	

EW-34.25" Wide	HW-40.28" Wide	MW-46.97" Wide	DW-56.34" Wide
440 lbs. (200kg)	440 lbs. (200kg)	440 lbs. (200kg)	440 lbs. (200kg)
EW	HW	MW	DW
EWDR-LR312-75 EWDR518-100 EWDR518-100 EWDR212-150 EWDR212-200 EWDR-LR312-250	HWDR524-75 HWDR524-100 HWDR524-100 HWDR312-150 HWDR209-200 HWDR-LR106-250	MWDR628-75 MWDR-LR415-100 MWDR-LR415-100 MWDR420-150 MWDR-LR209-200 MWDR-LR106-250	DWDR-LR415-75 DWDR-LR415-100 DWDR-LR415-100 DWDR-LR415-150 DWDR-LR312-200 DWDR-LR106-250
EW0900-0603F-M- <input type="checkbox"/> EW0900-0603FA-M- <input type="checkbox"/>	HW0900-0603F-M- <input type="checkbox"/> HW0900-0603FA-M- <input type="checkbox"/>	MW0900-0603F-M- <input type="checkbox"/> MW0900-0603FA-M- <input type="checkbox"/>	DW0900-0603F-M- <input type="checkbox"/> DW0900-0603FA-M- <input type="checkbox"/>
EW	HW	MW	DW
EWDR518-100 EWDR518-100 EWDR415-100 EWDR415-100 EWDR310-150 EWDR310-150 EWDR212-200	HWDR524-100 HWDR524-100 HWDR420-100 HWDR420-100 HWDR312-150 HWDR312-150 HWDR209-200	MWDR-LR415-100 MWDR-LR415-100 MWDR-LR312-100 MWDR-LR312-100 MWDR-LR209-150 MWDR-LR209-150 MWDR-LR106-200	DWDR-LR415-100 DWDR-LR415-100 DWDR-LR312-100 DWDR-LR312-100 DWDR-LR209-150 DWDR-LR209-150 DWDR-LR106-200
EW0900-0702F-M- <input type="checkbox"/> EW0900-0702FA-M- <input type="checkbox"/>	HW0900-0702F-M- <input type="checkbox"/> HW0900-0702FA-M- <input type="checkbox"/>	MW0900-0702F-M- <input type="checkbox"/> MW0900-0702FA-M- <input type="checkbox"/>	DW0900-0702F-M- <input type="checkbox"/> DW0900-0702FA-M- <input type="checkbox"/>
EW	HW	MW	DW
EWDR518-75 EWDR518-75 EWDR415-100 EWDR415-100 EWDR415-100 EWDR310-150 EWDR310-150 EWDR310-150	HWDR036-75 HWDR036-75 HWDR628-100 HWDR628-100 HWDR628-100 HWDR312-150 HWDR312-150 HWDR312-150	MWDR732-75 MWDR732-75 MWDR628-100 MWDR628-100 MWDR628-100 MWDR-LR312-150 MWDR-LR312-150 MWDR-LR312-150	DWDR836-75 DWDR836-75 DWDR732-100 DWDR732-100 DWDR732-100 DWDR-LR415-150 DWDR-LR415-150 DWDR-LR415-150
EW0900-0802F-M- <input type="checkbox"/> EW0900-0802FA-M- <input type="checkbox"/>	HW0900-0802F-M- <input type="checkbox"/> HW0900-0802FA-M- <input type="checkbox"/>	MW0900-0802F-M- <input type="checkbox"/> MW0900-0802FA-M- <input type="checkbox"/>	DW0900-0802F-M- <input type="checkbox"/> DW0900-0802FA-M- <input type="checkbox"/>
EW	HW	MW	DW
EWDR518-75 EWDR518-75 EWDR415-75 EWDR415-75 EWDR415-100 EWDR310-100 EWDR310-100 EWDR-LR312-150 EWDR-LR312-150	HWDR524-75 HWDR524-75 HWDR420-75 HWDR420-75 HWDR420-100 HWDR312-100 HWDR312-100 HWDR209-150 HWDR209-150	MWDR-LR415-75 MWDR-LR415-75 MWDR-LR415-75 MWDR-LR415-75 MWDR-LR312-100 MWDR-LR312-100 MWDR-LR312-100 MWDR-LR209-150 MWDR-LR209-150	DWDR-LR415-75 DWDR-LR415-75 DWDR-LR415-75 DWDR-LR415-75 DWDR-LR312-100 DWDR-LR312-100 DWDR-LR312-100 DWDR-LR209-150 DWDR-LR209-150
EW0900-0901F-M- <input type="checkbox"/> EW0900-0901FA-M- <input type="checkbox"/>	HW0900-0901F-M- <input type="checkbox"/> HW0900-0901FA-M- <input type="checkbox"/>	MW0900-0901F-M- <input type="checkbox"/> MW0900-0901FA-M- <input type="checkbox"/>	DW0900-0901F-M- <input type="checkbox"/> DW0900-0901FA-M- <input type="checkbox"/>

MOBILE ACCESSORIES

Choose from a variety of accessories for your mobile cabinets and work centers.

Black Plastic Handles

Handles mounted on front of cabinet. Cabinets are pre-drilled and handles are mounted in the field. Hardware included.



Black Plastic Handles

PART NO.	FOR USE WITH
MHAN	NW, MP and CL cabinets

Tubular Steel Handles

Handles mount on the front of single MP and SC Width mobile cabinets, and on the side of all other cabinet sizes. Cabinets are pre-drilled and handles are mounted in the field. Hardware included.



Tubular Steel Handles

PART NO.	FOR USE WITH
MTBH	all cabinets except NW

Tech Series Side Push Handle

Single aluminum extruded tubing with a brushed silver finish and black synthetic ends (not pictured) attaches to side of mobile cabinets. Cabinets have threaded inserts and handle is mounted in the field. Hardware included.



Tech Series Side Push Handle

PART NO.	FOR USE WITH
SPH/27-TS	all shallow depth cabinets (except NS) and workcenters
SPH/36-TS	all full depth cabinets (except NW & MP) and workcenters

Push Handles

Single tubular steel handle attaches to side of mobile cabinet to push tall, large and/or heavily loaded cabinets. Cabinets are pre-drilled and handles are mounted in the field. Hardware included.



Push Handles

PART NO.	FOR USE WITH
HSG-HNDL/27	all shallow depth cabinets (except NS) and workcenters
HSG-HNDL/36	all full depth cabinets (except NW & MP) and workcenters

Folding Shelves

Shelf can be mounted on either the left or right side of any mobile or stationary cabinet. 50 lb. maximum capacity. Shelf is 15" wide and is available for full and shallow depth cabinets. Can not be used with cabinets that have front-mounted tubular steel handles (MTBH). Only compatible with front-mounted black plastic handles (MHAN) or side-mounted tubular steel handles (MTBH).



Folding Shelves

PART NO.	DEPTH	MOUNTS TO
FULL DEPTH		
FS-36DX15-L	28 1/2"	left side
FS-36DX15-R	28 1/2"	right side
SHALLOW DEPTH		
FS-27DX15-L	22 1/2"	left side
FS-27DX15-R	22 1/2"	right side

Hanging Shelf Cabinets

Optional shelf cabinet, painted to match mobile cabinet, is 15" deep x 29" high. It is attached to the side of mobile cabinet for easy maneuvering. Each cabinet has a bottom shelf and 1 adjustable 13 1/2" deep shelf. Individual lock (RG) and 2 keys are furnished. Can only be mounted on 750 height or higher mobile cabinets.



Hanging Shelf Cabinets

PART NO.	DESCRIPTION
FULL DEPTH	
OHC2829-CM	full depth shelf cabinet
OHC1BCT/36	butcher block top for OHC2829
SHALLOW DEPTH	
OHC2329-CM	shallow depth shelf cabinet
OHC1BCT/27	butcher block top for OHC2329

MOBILE ACCESSORIES

Individual Casters

Individual replacement casters (not mounted to a mobile base) are available to suit the weight-bearing needs of your application. Capacity shown is per caster.

Industrial strength polyurethane tread bonded to "ribbed" polyolefin core. This design adds strength for loads subjected to shock and hard impacts. Tread is molded in, around and through a ribbed extension of the core to prevent debonding. Standard colors are red tread on grey core.

Not recommended for conditions of continuous operation such as tow-line, etc. Temperature range: -45°F to +180°F.

Hardness: 55(±5) Durometer Shore D scale.

Performa wheels offer the advantages of both hard and soft tread materials in a single wheel. Like a hard tread wheel, Performa rolls easily and is very durable. Like a soft tread wheel, it rolls quietly, protects floors and resists impacts with a cushion ride. It also features maximum weatherability, low temperature flexibility, resistance to chemicals, water and steam, and rejects floor debris such as metal shavings. Non-marking thermoplastic elastomer tread is permanently bonded to ribbed polyolefin wheel core.

Temperature range: -45°F to +180°F intermittent service (120° continuous service).

Hardness: 65(±5) Durometer Shore A scale.



250 Lb. Capacity

PART NO.	DESCRIPTION
CAST4X1.25	4" x 1 1/4" set (2 fixed, 2 swivel)
CAST4X1.25R	4" x 1 1/4" fixed (1)
CAST4X1.25S	4" x 1 1/4" swivel (1)

350 Lb. Capacity

PART NO.	DESCRIPTION
CAST4X2	4" x 2" set (2 fixed, 2 swivel)
CAST4X2R	4" x 2" fixed (1)
CAST4X2S	4" x 2" swivel (1)

600 Lb. Capacity

PART NO.	DESCRIPTION
CAST6X2	6" x 2" set (2 fixed, 2 swivel)
CAST6X2R	6" x 2" fixed (1)
CAST6X2S	6" x 2" swivel (1)

900 Lb. Capacity

PART NO.	DESCRIPTION
CAST6X2ML	6" x 2" set (2 fixed, 2 swivel)
CAST6X2RML	6" x 2" fixed (1)
CAST6X2SML	6" x 2" swivel (1)

MOBILE FORK TRUCK BASE

Available on all MP model cabinets, the Mobile Fork Truck Base combines the qualities and characteristics of mobile base casters and a Fork Truck Base, with the added benefit of a captive pocket to ensure the cabinet stay on the blades of the lift truck. The opening is approximately 7 1/2" wide x 2" high and adds an additional 2" to the height of a standard mobile base.



KICKSTAND

Purchased separately, the Kickstand comes welded to the side of any mobile cabinet footprint, to increase stability and prevent tipping hazards. Meeting ANSI/BIFMA x5.9-2012 requirements, it can also serve as a hinged lock bar (HLB) and does not interfere with the mobility of the cabinet. Product is manually operated.



Mobile Fork Truck Base

PART NO.	DESCRIPTION
MP-FTB/M-4B	FTB W/CVRS 27/36 MOBILE
MP-FTB/M-4ML	FTB W/CVRS 27/36 MOBILE
MP-FTB/M-6B	FTB W/CVRS 27/36 MOBILE
MP-FTB/M-6ML	FTB W/CVRS 27/36 MOBILE

Contact your Lista sales representative for part numbers and how to order.

TECH SERIES TOOLBOXES – A TECHNICIAN'S DREAM

Your service business's success depends on your team's ability to do high-quality, timely work. To do their best work, your technicians need the right tool storage and access for the job. The wrong toolbox can slow productivity and affect job turnaround, resulting in customer dissatisfaction and lost business.

Equip your technicians with Lista® Technician Series toolboxes that are rugged enough to withstand a beating, spacious enough to hold everything they need them to, flexible enough to suit their work style, and organized for maximum efficiency. They're the best quality tool storage you can get your hands on – at the best price.

With Lista, you get it all – the largest capacity, most durable boxes on the market, at a price that boxes out the competition.

Compare our features and you'll see the difference:

- Rugged design backed by limited lifetime warranty
- Fully welded drawer and housing construction
- Heavy-duty casters (1,200 lbs. each)
- 440 lb. capacity full-extension drawers
- Sub-dividable drawers
- Twelve standard drawer heights available from 2" - 13"
- Multiple full-width configurations
- Premium non-slip mesh drawer liners
- Five standard gloss finish powder coated colors, with two-tone color schemes available
- Drawer pull finish options enhance appearance and add style

Includes central lock with keyed-alike capability for multiple units

All mobile units include side push handle

Drawer handles are flush with housing so clothing won't snag

Drawer compartments for bulk storage

Total lock break on swivel casters in mobile configurations

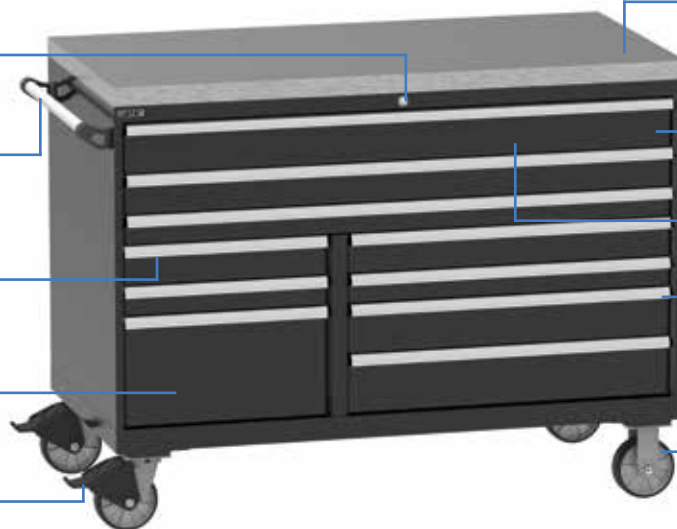

Available in a variety of work surfaces

All drawers are full extension with 440 lb. capacity

PrevenTip® safety system

Mobile units include individual drawer latches for safe transport

Most models available in either mobile or stationary configuration

Double Bank Toolbox

How to order a Preconfigured Technician Series Toolbox

1. Select toolbox configuration on pages 112-117.
2. ■ Select base type on page 118.
 - 2LB = 2" Leveling base with stainless steel kick plate
 - WC = stationary raised base with stainless steel feet
 - M = mobile base (not recommended for Model 1350)
3. Select paint color. For color chart, see page 119.
4. Select Drawer handle Pulls (optional see page 119)
5. Select cabinet top or counter top (optional see page 120)
6. Select Drawer Interiors (optional see page 121)

EXAMPLE: to order an TSDW0750-0721 toolbox with a mobile base in a Black housing with Red drawers, the part ordering number would be **TSDW0750-0721-MBKG-NRG**. To order a butcher block top for your toolbox, include part number **DW1BCT**.

To custom design your own toolbox, contact your Lista sales representative.

1. SELECT TOOLBOX

DOUBLE BANK TOOLBOX



Housing Heights:
750, 900, 1050

Housing Widths:
DW Combo Housing (56.5")
(Left Bay) MP (Right Bay) EW
Total Length with Handle: 60"

Depths:
Full (28.5")

DOUBLE BANK TOOLBOX FOOTPRINTS – AVAILABLE IN 5 HEIGHTS

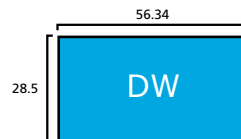

TRIPLE BANK TOOLBOX



Housing Heights:
750, 900, 1050

Housing Widths:
DW Combo Housing (56.5")
(Left Bay) MP (Right Bay) EW
Right Cabinet: MP (22.2")
Total length with Handle: 82.25"

Depths:
Full (28.5")

TRIPLE BANK TOOLBOX FOOTPRINTS – AVAILABLE IN 3 HEIGHTS

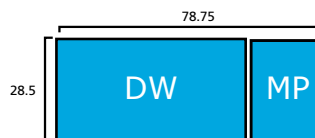

1. MODEL 750 DOUBLE BANK TOOLBOXES

41½" high mobile toolbox*

*other base options also available

(housing height without base is 33½")

- Select from 6 different configurations (with more available at ListaBox.com)
- Choice of mobile or stationary bases
- All units include protective ribbed rubber mat on top. Additional top choices available.
- All drawers include premium mesh drawer liner
- Top drawer includes divider and bin tool organization starter kit
- Drawer heights shown in charts indicate useable height of drawer
- All Double Bank drawers are full extension with a **440lb.** capacity
- To custom design your own toolbox, contact your Lista representative

*All orders must include choice of base and color

To complete part number, specify base type and paint color .
See page 111 for complete ordering instructions.



TSDW07C04-1101FL-MNRG
WITH OPTIONAL BUTCHER BLOCK TOP

*All drawers have 440 lb. weight cap.

Usable inside drawer dimensions:

- Top bank (DW drawer): 52" W x 24" D
- Left bank (MP drawer): 18" W x 24" D
- Right bank (EW drawer): 30" W x 24" D

DOUBLE BANK POPULAR CONFIGURATIONS



11 drawers, including 3 full width drawers
56½" wide (60" wide including handle)
28,570 cubic inches • 8,708 square inches

PART NO. TSDW07C04-1101FL- DEPTH 28½"



10 drawers, including 3 full width drawers
56½" wide (60" wide including handle)
29,142 cubic inches • 7,983 square inches

PART NO. TSDW07C04-1003FL- DEPTH 28½"



10 drawers, including 2 full width drawers
56½" wide (60" wide including handle)
29,560 cubic inches • 7,450 square inches

PART NO. TSDW07C04-1002FL- DEPTH 28½"



9 drawers, including 2 full width drawers
56½" wide (60" wide including handle)
30,132 cubic inches • 6,725 square inches

PART NO. TSDW07C04-0901FL- DEPTH 28½"



12 drawers, including 1 full width drawer
56½" wide (60" wide including handle)
28,723 cubic inches • 7,789 square inches

PART NO. TSDW07C06-1201FL- DEPTH 28½"



11 drawers, including 1 full width drawer
56½" wide (60" wide including handle)
29,065 cubic inches • 7,354 square inches

PART NO. TSDW07C06-1102FL- DEPTH 28½"

1. MODEL 750 TRIPLE BANK TOOLBOXES

41½" high mobile toolbox*

*other base options also available

(housing height without base is 33½")

- Mobile bases include 4 end swivel and 2 center fixed 6" x 2" heavy-duty casters (1,200 lbs. each) with total lock brakes
- All units include protective ribbed rubber mat on top. Additional top choices available.
- Both locks are keyed-alike
- All drawers include premium mesh drawer liner
- Top drawer includes divider and bin tool organization starter kit
- All Triple Bank drawers are full extension with a **440 lb. capacity**

*All orders must include choice of base and color

To complete part number, specify paint color .

See page 111 for complete ordering instructions.



TSTB750-1801-M293
WITH OPTIONAL VINYL MAT TOP

All drawers have 440 lb. weight cap.

Usable inside drawer dimensions:

- Top bank (DW drawer): 52" W x 24" D
- Left bank (MP drawer): 18" W x 24" D
- Middle bank (EW drawer): 30" W x 24" D
- Right bank (MP drawer): 18" W x 24" D

TRIPLE BANK POPULAR CONFIGURATIONS



14 drawers, including 3 full width drawers
78¾" wide (82¼" wide including handle)
40,398 cubic inches • 10,014 square inches

PART NO. TSTB750-1401- DEPTH 28½"



17 drawers, including 3 full width drawers
78¾" wide (82¼" wide including handle)
39,370 cubic inches • 11,320 square inches

PART NO. TSTB750-1702- DEPTH 28½"



18 drawers, including 3 full width drawers
78¾" wide (82¼" wide including handle)
39,027 cubic inches • 11,756 square inches

PART NO. TSTB750-1801- DEPTH 28½"



18 drawers, including 3 full width drawers
78¾" wide (82¼" wide including handle)
39,256 cubic inches • 11,466 square inches

PART NO. TSTB750-1802- DEPTH 28½"

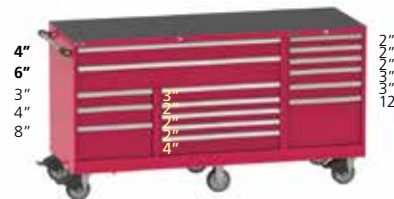

16 drawers, including 2 full width drawers
78¾" wide (82¼" wide including handle)
40,360 cubic inches • 10,062 square inches

PART NO. TSTB750-1601- DEPTH 28½"



19 drawers, including 1 full width drawer
78¾" wide (82¼" wide including handle)
39,179 cubic inches • 10,837 square inches

PART NO. TSTB750-1901- DEPTH 28½"

1. MODEL 900 DOUBLE BANK TOOLBOXES

47³/₈" high mobile toolbox*

*other base options also available

(housing height without base is 39³/₈"

- Select from 6 different configurations (with more available at ListaBox.com)
- Choice of mobile or stationary bases
- All units include protective ribbed rubber mat on top. Additional top choices available.
- All drawers include premium mesh drawer liner
- Top drawer includes divider and bin tool organization starter kit
- Drawer heights shown in charts indicate useable height of drawer
- All Double Bank drawers are full extension with a **440 lb.** capacity
- To custom design your own toolbox, contact your Lista representative

*All orders must include choice of base and color

To complete part number, specify base type and paint color .
See page 111 for complete ordering instructions.



TSDW09C06-1201FL
WITH OPTIONAL VINYL MAT TOP

*All drawers have 440 lb. weight cap.

Usable inside drawer dimensions:

- Top bank (DW drawer): 52" W x 24" D
- Left bank (MP drawer): 18" W x 24" D
- Right bank (EW drawer): 30" W x 24" D

DOUBLE BANK POPULAR CONFIGURATIONS



14 drawers, including 3 full width drawers
56¹/₂" wide (60" wide including handle)
34,170 cubic inches • 10,305 square inches

PART NO. TSDW09C06-1401FL- DEPTH 28¹/₂"



13 drawers, including 3 full width drawers
56¹/₂" wide (60" wide including handle)
34,513 cubic inches • 9,870 square inches

PART NO. TSDW09C06-1303FL- DEPTH 28¹/₂"



13 drawers, including 2 full width drawers
56¹/₂" wide (60" wide including handle)
35,161 cubic inches • 9,047 square inches

PART NO. TSDW09C06-1302FL- DEPTH 28¹/₂"



12 drawers, including 2 full width drawers
56¹/₂" wide (60" wide including handle)
35,503 cubic inches • 8,611 square inches

PART NO. TSDW09C06-1201FL- DEPTH 28¹/₂"



15 drawers, including 1 full width drawer
56¹/₂" wide (60" wide including handle)
34,094 cubic inches • 9,676 square inches

PART NO. TSDW09C07-1501FL- DEPTH 28¹/₂"



14 drawers, including 1 full width drawer
56¹/₂" wide (60" wide including handle)
34,665 cubic inches • 8,950 square inches

PART NO. TSDW09C07-1402FL- DEPTH 28¹/₂"

1. MODEL 900 TRIPLE BANK TOOLBOXES

47³/₈" high mobile toolbox*

*other base options also available

(housing height without base is 39³/₈")

- Choice of mobile or stationary bases
- Mobile bases include 4 end swivel and 2 center fixed 6" x 2" heavy-duty casters (1,200 lbs. each) with total lock brakes
- All units include protective ribbed rubber mat on top. Additional top choices available.
- Both locks are keyed-alike
- All drawers include premium mesh drawer liner
- Top drawer includes divider and bin tool organization starter kit
- All Triple Bank drawers are full extension with a **440 lb. capacity**

*All orders must include choice of base and color

To complete part number, specify paint color . See page 111 for complete ordering instructions.



TSTB900-2001-M5003
WITH OPTIONAL VINYL MAT TOP

All drawers have 440 lb. weight cap.

Usable inside drawer dimensions:

- Top bank (DW drawer): 52" W x 24" D
- Left bank (MP drawer): 18" W x 24" D
- Middle bank: (EW drawer): 30" W x 24" D
- Right bank (MP drawer): 18" W x 24" D

TRIPLE BANK POPULAR CONFIGURATIONS



22 drawers, including 3 full width drawers
78³/₄" wide (82¹/₄" wide including handle)
46,855 cubic inches • 13,789 square inches

PART NO. TSTB900-2202- DEPTH 28¹/₂"



22 drawers, including 3 full width drawers
78³/₄" wide (82¹/₄" wide including handle)
46,855 cubic inches • 13,788 square inches

PART NO. TSTB900-2201- DEPTH 28¹/₂"

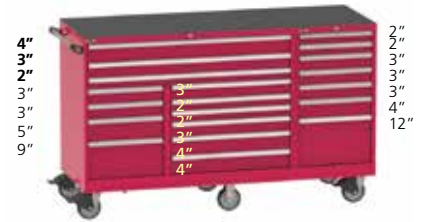

21 drawers, including 3 full width drawers
78³/₄" wide (82¹/₄" wide including handle)
47,198 cubic inches • 13,353 square inches

PART NO. TSTB900-2102- DEPTH 28¹/₂"



18 drawers, including 3 full width drawers
78³/₄" wide (82¹/₄" wide including handle)
48,226 cubic inches • 12,047 square inches

PART NO. TSTB900-1801- DEPTH 28¹/₂"



20 drawers, including 2 full width drawers
78³/₄" wide (82¹/₄" wide including handle)
48,189 cubic inches • 12,095 square inches

PART NO. TSTB900-2001- DEPTH 28¹/₂"



23 drawers, including 1 full width drawer
78³/₄" wide (82¹/₄" wide including handle)
47,007 cubic inches • 12,869 square inches

PART NO. TSTB900-2301- DEPTH 28¹/₂"

1. MODEL 1050 DOUBLE BANK TOOLBOXES

53¼" high mobile toolbox*

*other base options also available

(housing height without base is 45¼")

- Select from 6 different configurations (with more available at ListaBox.com)
- Choice of mobile or stationary bases
- All units include protective ribbed rubber mat on top. Additional top choices available.
- All drawers include premium mesh drawer liner
- Top drawer includes divider and bin tool organization starter kit
- Drawer heights shown in charts indicate useable height of drawer
- All Double Bank drawers are full extension with a **440 lb.** capacity
- To custom design your own toolbox, contact your Lista representative

*All orders must include choice of base and color

To complete part number, specify base type and paint color . See page 111 for complete ordering instructions.



TSDW10C07-1502FL-M12179
WITH OPTIONAL VINYL MAT TOP

*All drawers have 440 lb. weight cap.
Usable inside drawer dimensions:
Top bank (DW drawer): 52" W x 24" D
Left bank (MP drawer): 18" W x 24" D
Right bank (EW drawer): 30" W x 24" D

DOUBLE BANK POPULAR CONFIGURATIONS



16 drawers, including 3 full width drawers
56½" wide (60" wide including handle)
40,113 cubic inches • 11,466 square inches

PART NO. TSDW10C07-1601FL- DEPTH 28½"



15 drawers, including 3 full width drawers
56½" wide (60" wide including handle)
40,455 cubic inches • 11,030 square inches

PART NO. TSDW10C07-1503FL- DEPTH 28½"



15 drawers, including 2 full width drawers
56½" wide (60" wide including handle)
41,103 cubic inches • 10,208 square inches

PART NO. TSDW10C07-1502FL- DEPTH 28½"



14 drawers, including 2 full width drawers
56½" wide (60" wide including handle)
41,446 cubic inches • 9,773 square inches

PART NO. TSDW10C07-1401FL- DEPTH 28½"



17 drawers, including 1 full width drawer
56½" wide (60" wide including handle)
40,265 cubic inches • 10,547 square inches

PART NO. TSDW10C09-1701FL- DEPTH 28½"



16 drawers, including 1 full width drawer
56½" wide (60" wide including handle)
40,608 cubic inches • 10,111 square inches

PART NO. TSDW10C09-1602FL- DEPTH 28½"

1. MODEL 1050 TRIPLE BANK TOOLBOXES

53¼" high mobile toolbox*

*other base options also available

(housing height without base is 45¼")

- Choice of mobile or stationary bases
- Mobile bases include 4 end swivel and 2 center fixed 6" x 2" heavy-duty casters (1,200 lbs. each) with total lock brakes
- All units include protective ribbed rubber mat on top. Additional top choices available.
- Both locks are keyed-alike
- All drawers include premium mesh drawer liner
- Top drawer includes divider and bin tool organization starter kit
- All Triple Bank drawers are full extension with a **440 lb. capacity**

*All orders must include choice of base and color

To complete part number, specify paint color .
See page 111 for complete ordering instructions.



TSTB1050-2501-MBLK
WITH OPTIONAL VINYL MAT TOP

All drawers have 440 lb. weight cap.
Usable inside drawer dimensions:
Top bank (DW drawer): 52" W x 24" D
Left bank (MP drawer): 18" W x 24" D
Middle bank: (EW drawer): 30" W x 24" D
Right bank (MP drawer): 18" W x 24" D

TRIPLE BANK POPULAR CONFIGURATIONS



25 drawers, including 3 full width drawers
78¾" wide (82¼" wide including handle)
55,027 cubic inches • 15,385 square inches

PART NO. TSTB1050-2501-
DEPTH 28½"



25 drawers, including 3 full width drawers
78¾" wide (82¼" wide including handle)
55,026 cubic inches • 15,384 square inches

PART NO. TSTB1050-2502-
DEPTH 28½"



24 drawers, including 3 full width drawers
78¾" wide (82¼" wide including handle)
55,369 cubic inches • 14,949 square inches

PART NO. TSTB1050-2402-
DEPTH 28½"



22 drawers, including 3 full width drawers
78¾" wide (82¼" wide including handle)
56,055 cubic inches • 14,078 square inches

PART NO. TSTB1050-2201-
DEPTH 28½"



23 drawers, including 2 full width drawers
78¾" wide (82¼" wide including handle)
56,359 cubic inches • 13,691 square inches

PART NO. TSTB1050-2301-
DEPTH 28½"



26 drawers, including 1 full width drawer
78¾" wide (82¼" wide including handle)
55,179 cubic inches • 14,465 square inches

PART NO. TSTB1050-2601-
DEPTH 28½"

2. SELECT BASE (OPTIONAL)

Leveling Base (2LB)

Allows for quick and easy leveling from inside of cabinet. Includes a front cover that adjusts as cabinet is leveled. Base is available in multiple heights in cold-rolled, galvanealed steel steel with matching covers or stainless steel cover option. Adjustment tool, side skirts, anchor kit and glide cap kit are also available.

Height added to housing height: 2"



Wet Clean Base (WC)

Allows for easy cleaning below housing in areas where floors are often washed (such as labs and hospitals), or where wet floors are an issue. Raises cabinet housing 4 9/16" above floor. Individual leg height is further adjustable to allow for leveling (up to 1 3/4" additional height), even on extremely uneven surfaces. Cabinet can be lifted and moved with a hand pallet truck.

Height added to housing height: 4 1/2" - 6 1/4"



Mobile Caster Base (M)

Mobile base – 2 fixed and 2 swivel 6" x 2" heavy-duty casters (1,200 lbs. each) with total lock brakes. Triple bank and two-bay mobile bases have 4 center swivel mobile bases have 4 end swivel and 2 center fixed 6" x 2" heavy-duty casters (1,200 lbs. each) with total lock brakes

Height added to housing height: 8"



3. SELECT PAINT COLOR(S)

Tech Series Toolbox Colors



CODE COLOR
293 Blaze Blue



CODE COLOR
5003 Dusk Blue

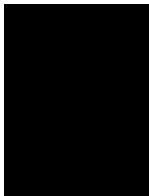

CODE COLOR
BKG Black



CODE COLOR
NRG Red



CODE COLOR
12179 Yellow



Note: Paint colors have a premium gloss finish.

4. SELECT DRAWER HANDLE PULLS (OPTIONAL)

Drawer Handle Pulls (Optional)

For those not requiring labeling of drawers or contents aluminum extruded covers are available in three finishes including: gloss black, chrome color, and brushed silver.



UPGRADE PART NUMBERS (REPLACES SCRIPT HANDLE COVER)

COLORS STYLE WIDTH	BRUSHED SILVER PART NO.	CHROME COLOR PART NO.	GLOSS BLACK PART NO.
CL/MP	HNDL-CLMP/BRSH	HNDL-CLMP/CHRM	HNDL-CLMP/GBLK
ES/EW	HNDL-ESEW/BRSH	HNDL-ESEW/CHRM	HNDL-ESEW/GBLK
HT/DW	HNDL-HTDW/BRSH	HNDL-HTDW/CHRM	HNDL-HTDW/GBLK

5. SELECT CABINET TOP OR COUNTER TOP (OPTIONAL)

Butcher Block Cabinet Tops

Tops are satin finish 1 3/4" thick hardwood and are flush to the cabinet side-to-side and front-to-back.



Stainless Steel Cabinet Covers

Cover is constructed of durable, heavy gauge stainless steel. Fits over top and sides of cabinet, and provides easy access to locking system. Adds 1/16" to overall cabinet height and 1/8" to overall width and depth.



Stainless Steel Over Wood Core (SS)

Worksurface is constructed of durable heavy gauge, 304 stainless steel cover, fitted over top and sides of wood core, 1 13/16" thick.



Work Top Options

SIZE	DIMENSIONS	STAINLESS STEEL TOP	STAINLESS STEEL COVER	BUTCHER BLOCK
DW	56 1/2" x 28 1/2"	DW1LSSCT	DW1SSC	DW1BCT
TSTB / TS-DWMP	78 3/4" x 28 1/2"	LSSCT-DWMP	SSC-DWMP	BCT-DWMP

6. SELECT DRAWER INTERIORS (OPTIONAL)

Customize your toolbox drawer interiors. Subdivide your drawers for ultimate flexibility in tool storage.

Toolbox drawers come standard with mesh drawer liners, and the top drawer of each toolbox includes a starter compartment divider kit. If you prefer to separate your tools within the other drawers, choose from the configurations shown below. Be sure to match drawer interior with correct drawer model and height.

How to order drawer interiors

To order the drawer interior sets shown on this page, use the part number in the chart and add the drawer height in place of the green box.

EXAMPLE: to order an MPDR206 drawer interior set for a 100 height (3") drawer, the part ordering number would be **MPDR206-100**.

**All toolboxes include one drawer divider starter kit. Your toolbox comes equipped with a DWDR516 divider starter kit in the top drawer.*

EW Drawers



For all drawer heights
PART NO. DRAWER INSIDE DIM.
EWDR104- EW 30" x 24"



For all drawer heights
PART NO. DRAWER INSIDE DIM.
EWDR207- EW 30" x 24"



For 2" - 7" high drawers only*
PART NO. DRAWER INSIDE DIM.
EWDR310- EW 30" x 24"

MP Drawers



For 2" high drawers only
PART NO. DRAWER INSIDE DIM.
MPDR028- MP 18" x 24"



For 2" and 3" high drawers only
PART NO. DRAWER INSIDE DIM.
MPDR018- MP 18" x 24"



For all drawer heights
PART NO. DRAWER INSIDE DIM.
MPDR103- MP 18" x 24"



For all drawer heights
PART NO. DRAWER INSIDE DIM.
MPDR104- MP 18" x 24"

DW Drawers



For all drawer heights
PART NO. DRAWER INSIDE DIM.
DWDR309- DW 52" x 24"



For all drawer heights
PART NO. DRAWER INSIDE DIM.
DWDR413- DW 52" x 24"



For 2" - 7" high drawers only*
PART NO. DRAWER INSIDE DIM.
DWDR516- DW 52" x 24"



For 2" - 7" high drawers only*
PART NO. DRAWER INSIDE DIM.
DWDR619- DW 52" x 24"

NC TOOL STORAGE

p.124-135



CNC AND MACHINE TOOL STORAGE, TRANSPORT AND USE CYCLE

With our many different CNC tool storage products and accessories, Lista provides an efficient, organized and secure link among all the various stages of tool storage, transport and use.



From the smallest shop to the largest machining operation, Lista can economically provide everything you need for safe and efficient storage of valuable tools.

Sliding door machine tool cabinets with butcher block tops provide both complete protection for tooling and a highly functional worksurface at Galileo Electro Optic Corporation's machine shop (left) and F&S Tool (right).



The Lista Storage Wall® System is used to store a variety of different-sized CNC tooling at Tremec, a manufacturer of manual transmissions. This vertical solution maximizes Tremec's floorspace while providing the company with safe, secure and completely organized CNC storage. For more information on the Lista Storage Wall System, see pages 138-149.

Lista CNC tool transporters are used to safely deliver tools directly to the work area at Continental Machines, a leading machine tool and hydraulic component manufacturing company.

TOOL HOLDERS

Safety and ease of use for storage and transport are the priorities in the design of the Lista system. Our tool holders are the basic components of an integrated solution to vertical storage of pre-set tools. Lista tool holders are ideal for all types of pre-set tool handling. Even if only small numbers of tools are involved, safe and accessible storage adjacent to machines is economical.

Molded Tool Holders

Tool holders are made from ABS high impact and oil resistant plastic that protects the heaviest tool shanks. Tool holders are designed to be held securely in place on either Lista tool trays or tool holder frames. Tool holders are available in red and green for easy visual identification of sharp and dull tooling.

Custom Tool Holders

Lista will modify blank inserts for any type, size or brand of tool holder (ABS, Capto, etc.). Each custom tool holder holds one tool. Provide your Lista representative with drawings and dimensions of the specific tools, and we will modify the blanks to your precise specifications. Tool holders are available in red and green for easy visual identification of sharp and dull tooling.

Tool Inserts

The tool blank fits a TT-1 tool tray, TF2736 tool frame or TF3636 tool frame. By boring or drilling (up to a maximum of 4" diameter), you can create custom tool holders to your precise specifications. The insert is made of 3/4" thick UHMW (ultra high molecular weight) polyethylene. Tool Inserts are available in red and green for easy visual identification of sharp and dull tooling.

Tool Blank

PART NO.	COLOR	LENGTH
TTB-RD	Red	21 1/16" (535mm)
TTB-GR	Green	21 1/16" (535mm)



Molded Tool Holders

PART NO.	DESCRIPTION	MAX. QTY./ROW	
		COLOR	36U 54U
12.880	30 taper	Red	8 12
12.062-RD	40 taper	Red	8 12
12.062-GR	40 taper	Green	8 12
12.875-RD	50 taper	Red	5 8
12.875-GR	50 taper	Green	5 8
12.883-RD	1 3/4" straight	Red	6 9
12.883-GR	1 3/4" straight	Green	6 9
12.882-RD	2" straight	Red	6 9
12.882-GR	2" straight	Green	6 9
15.319-RD	HSK50	Red	8 12
15.319-GR	HSK50	Green	8 12
15.320-RD	HSK63	Red	6 9
15.320-GR	HSK63	Green	6 9
15.336-RD	HSK100	Red	4 7
15.336-GR	HSK100	Green	4 7

Custom Tool Holders

PART NO.	TOOL SHANK	COLOR	MAX. QTY./ROW	
			36U	54U
STH50KM-RD	KM50	Red	7	12
STH50KM-GR	KM50	Green	7	12
STH63KM-RD	KM63	Red	6	10
STH63KM-GR	KM63	Green	6	10
STH50ABS-RD	ABS50	Red	9	14
STH50ABS-GR	ABS50	Green	9	14

Tool Inserts

PART NO.	TOOL SHANK	COLOR	NO. OF POSITIONS	
			36U	54U
TTB-KM40/12-RD	KM40	Red	12	
TTB-KM40/12-GR	KM40	Green	12	
TTB-KM40/15-RD	KM40	Red	15	
TTB-KM40/15-GR	KM40	Green	15	
TTB-KM50/6-RD	KM50	Red	6	
TTB-KM50/6-GR	KM50	Green	6	
TTB-KM50/8-RD	KM50	Red	8	
TTB-KM50/8-GR	KM50	Green	8	
TTB-KM63/5-RD	KM63	Red	5	
TTB-KM63/5-GR	KM63	Green	5	
TTB-KM63/6-RD	KM63	Red	6	
TTB-KM63/6-GR	KM63	Green	6	
TTB-HSK40/8-RD	HSK40	Red	8	
TTB-HSK40/8-GR	HSK40	Green	8	
TTB-HSK63/6-RD	HSK63	Red	6	
TTB-HSK63/6-GR	HSK63	Green	6	
TTB-HSK63/7-RD	HSK63	Red	7	
TTB-HSK63/7-GR	HSK63	Green	7	
TTB-HSK80/5-RD	HSK80	Red	5	
TTB-HSK80/5-GR	HSK80	Green	5	
TTB-HSK100/4-RD	HSK100	Red	4	
TTB-HSK100/4-GR	HSK100	Green	4	
TTB-HSK125/3-RD	HSK125	Red	3	
TTB-HSK125/3-GR	HSK125	Green	3	
TTB-HSK125/4-RD	HSK125	Red	4	
TTB-HSK125/4-GR	HSK125	Green	4	
TTB-ABS50/8-RD	ABS50	Red	8	
TTB-ABS50/8-GR	ABS50	Green	8	

TOOL TRAYS AND TOOL HOLDER FRAMES FOR DRAWERS

Tool Trays

Lista tool trays allow tools to be easily moved from drawer to transporter and back. They are designed to fit securely into drawers, tool transporters or in Bench Stands without the use of bolts. Made of heavy gauge welded steel, they are designed with a universal grid system that guarantees precise positioning of the tool holders. Handles retract down when not in use. Recommended for 150 height or higher drawers. Not compatible with TT-1 tool trays and TTBR brackets sold before May 2003.



Tool Trays

PART NO.	TRAYS PER DRAWER
TT-1	4 per SC side-to-side
	3 per ST side-to-side
	3 per MP front-to-back

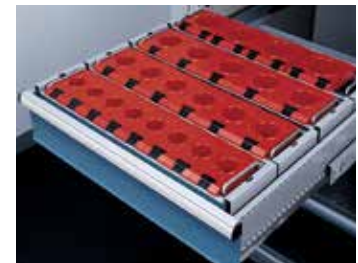

SC drawer with TT-1 tool trays and various-sized molded tool holders.

Tool Tray Drawer Brackets, Pairs

These supports are bolted into the perforated bottom of the Lista drawer. Mounted in pairs, they hold the TT-1 tool tray firmly in place. Made of heavy gauge steel. Not compatible with TT-1 tool trays sold before May 2003.



PART NO.	HEIGHT
TTBR-D	6"

Tool Holder Frames

Tool holder frames are mounted in drawers. They are bolted to pairs of brackets (see below), which in turn are bolted to the perforated drawer bottom. Recommended for 150 height or higher drawers.

Color: gray.

PART NO.	USE	ROW WID.	# ROWS
TF3636	SC drawers	36U	4
TF2736	MP and ST drawers	36U	3
TF5427	HS drawers	54U	3



SC drawer with TF3636 tool holder frame and molded tool holders.

Frame Drawer Brackets, Pairs

Pairs of brackets are bolted to the perforated bottom of a Lista drawer and to the sides of the frame. Height indicated is from the top of the frame to the drawer bottom.

PART NO.	USE	HEIGHTS
X4065	TF3636	2 5/8" or 3 1/2"
X4066	TF3636	4 3/8" or 5 3/4"
X4065-27	TF2736 or TF5427	2 5/8" or 3 1/2"
X4066-27	TF2736 or TF5427	4 3/8" or 5 3/4"

EASY-ORDER CNC AND MACHINE TOOL CABINET COMBINATIONS

Lista's CNC and machine tool storage cabinets can be arranged and equipped to meet your specific needs. Flexible combinations of drawers and roll-out trays are closed behind lockable hinged or sliding doors which protect tools from the working environment. The addition of a butcher block top or retainer top with ribbed mat provides a highly functional worksurface. (To order a top for these cabinets, contact your Lista representative.)

Ordering

To order a custom CNC or machine tool cabinet, please contact your Lista representative.

The CNC and machine tool storage cabinets shown here come fully equipped with tool holder frames and tool holders for a variety of standard sizes of CNC tools. Drawers are accessorized with partitions and dividers to hold measuring and cutting tools, collets, vises and other accessories. As in all Lista cabinets, their modular design means drawers and roll-out trays can be easily reconfigured for changing needs.

All drawers and roll-out trays are 100% full extension with a 440 lb. load capacity.

How to order an Easy-Order tool cabinet

Please note that the final digits in the ordering charts refer to the specific tool sizes (for example, MTC9150NC/40 stores 40 taper tools).

1. Select Easy-Order Cabinet Combination.

2. ■ Select base type.

- NB** = none
- FT** = fork truck
- 2LB** = 2" leveling base

3. ■ Select lock type.

- RG** = individual
- KA** = keyed-alike
- MA** = master

For additional lock options, see pages 82–83.

4. □ Select paint color. For color chart, see inside back cover.

EXAMPLE: to order an MTC900NC/30 cabinet with a fork truck base, an individual lock and Bright Blue paint, the part number would be **MTC900NC/30-FTRGBB**.



MTC9150 Machine Tool Cabinets

28 1/4" wide x 29 1/2" deep x 39 3/8" high

Lower hinged door compartment contains 3 drawers and a single roll-out tray for larger items. One drawer is fitted with a frame and tool holders. Separate 2-drawer upper level is partitioned for small tools. Upper and lower sections lock separately. Cabinet comes fully assembled with a retainer top with 3/4" raised edges on back and sides and a ribbed mat.

PART NO.	TOOL HOLD.	QTY.
EASY-ORDER COMBINATIONS		
MTC9150NC/30- ■ ■ □	12.880	32
MTC9150NC/40- ■ ■ □	12.062	28

HOUSING ONLY	HEIGHT
MTC9150- ■ ■ □	39 3/8"

MTC900 Machine



Tool Cabinets

28 1/4" wide x 29 1/2" deep x 39 3/8" high

This hinged door cabinet contains 5 drawers and a single roll-out tray. Lower drawer is fitted with a frame and tool holders, and upper drawers are partitioned for small tools and accessories. Cabinet comes fully assembled with a retainer top with 3/4" raised edges on back and sides and a ribbed mat.

PART NO.	TOOL HOLD.	QTY.
EASY-ORDER COMBINATIONS		
MTC900NC/30- ■ ■ □	12.880	32
MTC900NC/40- ■ ■ □	12.062	32
MTC900NC/50- ■ ■ □	12.875	20

HOUSING ONLY	HEIGHT
SCDHD900- ■ ■ □	39 3/8"



1350NC Machine

Tool Cabinets

28 1/4" wide x 29 1/2" deep x 59 1/2" high

This hinged door cabinet contains 4 drawers fully outfitted with frames and tool holders. **Includes fork truck base.**

PART NO.	TOOL HOLD.	QTY.
EASY-ORDER COMBINATIONS		
1350NC/40- ■ □	12.062	112
1350NC/50- ■ □	12.875	80
1350NC/HSK50- ■ □	15.319	128
1350NC/HSK63- ■ □	15.320	96

HOUSING ONLY	HEIGHT
SCDHD1350-FT ■ □	57 1/8"

1500NC Machine

Tool Cabinets

28 1/4" wide x 29 1/2" deep x 63" high

This hinged door cabinet contains 5 drawers fully outfitted with frames and tool holders. **Includes fork truck base.**

PART NO.	TOOL HOLD.	QTY.
EASY-ORDER COMBINATIONS		
1500NC/40- ■ □	12.062	140
1500NC/50- ■ □	12.875	100
1500NC/HSK50- ■ □	15.319	160
1500NC/HSK63- ■ □	15.320	120

HOUSING ONLY	HEIGHT
SCDHD1500-FT ■ □	64"

EASY-ORDER CNC WORKBENCHES

Rugged, durable Lista workbenches are ideal for setting and assembling CNC tools as well as for storing accessories adjacent to any machine. The models shown below are fully outfitted with drawer partitioning.

All cabinet housings and leg assemblies are constructed of welded heavy gauge steel. All drawers are 100% full extension with a 440 lb. load capacity. Bench tops are 1 3/4" (45mm) thick butcher block.

MTC900-5

56 1/2" wide x 30 3/4" deep x 39 3/8" high

This is a Double Width sliding door cabinet. Side A contains 6 drawers with partitioning for tool holder accessories, and a roll-out tray for large items. Side B has 2 drawers outfitted with frames and tool holders. Retainer top with 3/4" raised edges on back and sides and a ribbed mat is included.



Side A



Side B

MTC900-5

PART NO.	TOOL HOLD.	QTY.
EASY-ORDER COMBINATIONS		
MTC9005NC/30- <input type="checkbox"/> <input type="checkbox"/>	12.880	64
MTC9005NC/40- <input type="checkbox"/> <input type="checkbox"/>	12.062	56
MTC9005NC/50- <input type="checkbox"/> <input type="checkbox"/>	12.875	40
MTC9005NC/HSK50- <input type="checkbox"/> <input type="checkbox"/>	15.319	64
MTC9005NC/HSK63- <input type="checkbox"/> <input type="checkbox"/>	15.320	48

HOUSING ONLY	HEIGHT
MTC900-5 <input type="checkbox"/> <input type="checkbox"/> *	39 3/8"
MTC750-5 <input type="checkbox"/> <input type="checkbox"/> *	33 1/2"

*does not include retainer top or ribbed mat

CNC Bench Stand

Bench Stands are made of heavy gauge steel for maximum strength and stability, and trays can be inserted or removed without the use of bolts. Not compatible with TT-1 tool trays sold before May 2003.

Bench Stand Combinations

23 5/8" wide x 19 13/16" deep x 12 7/16" high

Equipped as shown with 3 tool holder trays and tool holders. Specify the part number for the tool holder size you require. Specify paint color in place of the box () at the end of the part number (see color chart on inside back cover).

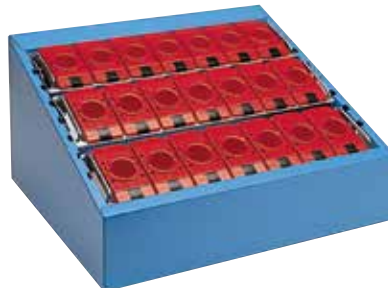

Bench Stand Combinations

PART NO.	TOOL HOLD.	QTY.
EASY-ORDER COMBINATIONS		
TS224-30- <input type="checkbox"/>	12.880	24
TS224-40- <input type="checkbox"/>	12.062	21
TS224-50- <input type="checkbox"/>	12.875	15
TS224-HSK50- <input type="checkbox"/>	15.319	24
TS224-HSK63- <input type="checkbox"/>	15.320	18

FRAME ONLY
TS224

MC750-A

60" wide x 30" deep x 35 1/4" high

This pre-set bench has 5 drawers, fully outfitted with drawer partitioning for storage of hand tools, collets, hardware and set-up equipment. The bottom drawer is outfitted with a frame and tool holders. Specify the part number for the tool holder size you require.



MC750-A

PART NO.	TOOL HOLD.	QTY.
MC750-A-30- <input type="checkbox"/>	12.880	32
MC750-A-40- <input type="checkbox"/>	12.062	28
MC750-A-50- <input type="checkbox"/>	12.875	20
MC750-A-HSK50- <input type="checkbox"/>	15.319	32
MC750-A-HSK63- <input type="checkbox"/>	15.320	24

MC750-B

60" wide x 30" deep x 35 1/4" high

This pre-set bench has 3 drawers – 1 drawer outfitted with drawer partitioning for small tools, and 2 deep drawers outfitted with frames and tool holders. Specify the part number for the tool holder size you require.



MC750-B

PART NO.	TOOL HOLD.	QTY.
MC750-B-30- <input type="checkbox"/>	12.880	64
MC750-B-40- <input type="checkbox"/>	12.062	56
MC750-B-50- <input type="checkbox"/>	12.875	40
MC750-B-HSK50- <input type="checkbox"/>	15.319	64
MC750-B-HSK63- <input type="checkbox"/>	15.320	48

How to order an Easy-Order CNC workbench

Please note that the final digits in the ordering charts refer to the specific tool sizes (for example, MC750-A-40 stores 40 taper tools).

1. Select Easy-Order workbench.

2. Select lock type.

- NL** = none
- RG** = individual
- KA** = keyed-alike
- MA** = master
- KP** = keypad lock

For additional lock options, see page 64.

3. Select paint color. For color chart, see inside back cover.

EXAMPLE: to order an MC750-B-30 workbench with an individual lock and Bright Blue paint, the part number would be **MC750-B-30-RGBB**.

EASY-ORDER TOOL CRIB CABINET COMBINATIONS

Lista cabinets, with their modular drawer interiors, are ideal for tool crib storage.

The cabinets on these pages contain everything you need to properly and efficiently store all items shown in the charts. Lista has pre-assembled these specific combinations because they are the most frequently ordered combinations.

Chosen for the specific parts shown, drawers can easily be rearranged within the cabinet or within cabinet groupings.

Drawers are 100% full extension with a 440 lb. (200kg) weight capacity. They have usable inside dimensions of 24" (610mm) wide x 24" (610mm) deep.

Model 900 Cabinet Combinations

28 1/4" wide x 28 1/2" deep x 39 3/8" high

Model 900 cabinets are convenient for a counter height worksurface. All drawers are 100% full extension with a 440 lb. load capacity.



How to order an Easy-Order Tool Crib Cabinet

1. Select Easy-Order Tool Crib Cabinet Combination.

2. ■ Select base type.

NB = none
FT = fork truck
2LB = leveling base

3. ■ Select lock type.

NL = none
RG = individual
KA = keyed-alike
MA = master
KP = keypad lock

For additional lock options, see pages 82–83.

4. Select paint color. For color chart, see inside back cover.

EXAMPLE: to order a TCC-4 cabinet with a fork truck base, an individual lock and Bright Blue paint, the part number would be **TCC-4-FTRGBB**.



TCC-1-■■

Drills & Taps (11 Drawers)

QTY.	DRW.	STORE
1	SC75F	number drills 1 thru 80
1	SC75F	letter drills A thru Z center drills 00 thru 8
1	SC75F	fractional drills, jobbers 1/64" thru 1/2" x 1/64"
1	SC75F	fractional drills, specials 1/64" thru 1/2" x 1/64"
1	SC75F	standard tapers 0-80 thru 1/4" -28"
1	SC75F	5/16" -18" thru 7/8" -20"
1	SC100F	15/16" -16" thru 2" -16"
1	SC100F	pipe taps, sleeves, easy outs
2	SC75F	assigned cutting tools
1	SC100F	assigned cutting tools

TCC-2-■■

Taper Shank Drills (10 Drawers)

QTY.	DRW.	STORE
1	SC75F	taper shank drills 33/64" thru 25/32" x 1/64" (4 each)
1	SC75F	5/16" thru 1 1/32" x 1/64" (4 each)
1	SC100F	1 3/64" thru 1 11/64" x 1/64" (4 each)
1	SC100F	1 3/16" thru 1 5/16" x 1/64" (4 each)
1	SC100F	1 21/64" thru 1 27/64" x 1/64" (4 each)
1	SC100F	1 7/16" thru 1 1/2" x 1/64" (6 each)
1	SC75F	1 17/32" thru 1 11/16" x 1/32" (2 each)
1	SC75F	1 23/32" thru 1 7/8" x 1/32" (2 each)
1	SC100F	1 29/32" thru 2" x 1/32" (2 each) (2) expansion or 1/64" sizes
1	SC100F	drifts, sleeves, and reserve drills

TCC-3-■■

Milling (10 Drawers)

QTY.	DRW.	STORE
4	SC75F	milling cutters, slitting saws
1	SC75F	end mills 1/8" thru 1/2"
1	SC100F	17/32" thru 1"
1	SC100F	1 1/8" thru 1 1/2"
1	SC100F	hog, ball, and other
1	SC100F	key cutters
1	SC125F	slab & face mills

TCC-4-■■

Reamers & Supplies (10 Drawers)

QTY.	DRW.	STORE
1	SC75F	chucking reamers, st-sk 1/16" thru 17/32" x 1/64"
1	SC75F	9/16" thru 1" x 1/32"
1	SC75F	misc. over 1"
1	SC75F	counter bores and pilots
2	SC75F	assigned cutting tools
1	SC100F	emery sheets
1	SC100F	burrs, stones and mounted points
1	SC100F	allen keys and chuck key
1	SC150F	stamps, punches, mallets

TCC-5-■■

Turning (10 Drawers)

QTY.	DRW.	STORE
1	SC75F	tool holder repair parts, anvils, screws, clamps, shims
1	SC75F	carbide brazed & high speed tools
2	SC75F	s.s. boring bars
2	SC75F	insert tool holders
3	SC100F	carbide inserts
1	SC150F	turret tool holders

TCC-6-■■

Precision Tools (10 Drawers)

QTY.	DRW.	STORE
2	SC75F	micrometers
1	SC75F	plain plug gages
1	SC75F	thread plug gages
1	SC75F	plain and thread rings
1	SC75F	verniers, gages, indicators, etc.
2	SC100F	verniers, gages, indicators, etc.
2	SC125F	verniers, gages, indicators, etc.

TCC-7-■■

Hand Tools (7 Drawers)

QTY.	DRW.	STORE
2	SC75F	files
3	SC100F	hand tools
1	SC200F	power tools
1	SC250F	power tools

TCC-8-■■

Fasteners (10 Drawers)

QTY.	DRW.	STORE
4	SC75F	fasteners, all types
6	SC100F	fasteners, all types

Model 1350 Cabinet Combinations

28 1/4" wide x 28 1/2" deep x 57 1/8" high

Model 1350 cabinets are eye level height and provide more storage in the same footprint as the Model 900. All drawers are 100% full extension with a 440 lb. load capacity.



TCC-21-■■■□

Drills & Taps (15 Drawers)

QTY.	DRW.	STORE
1	SC75F	number drills 1 thru 80
1	SC75F	letter drills A thru Z center drills 00 thru 8
1	SC75F	fractional drills, jobbers 1/64" thru 1/2" x 1/64"
1	SC75F	fractional drills, specials 1/64" thru 1/2" x 1/64"
1	SC75F	standard taps 0-80 thru 1/4"-28"
1	SC75F	5/16" - 18" thru 7/8" - 20"
1	SC100F	1 5/16" - 16" thru 2" - 16"
1	SC100F	pipe taps, sleeves, easy outs
2	SC75F	assigned cutting tools
3	SC100F	assigned cutting tools
1	SC125F	tap adapters, collets and extensions
1	SC125F	drill collets

TCC-22-■■■□

Taper Shank Drills (16 Drawers)

QTY.	DRW.	STORE
1	SC75F	frac. T.S. drills 33/64" thru 23/32" x 1/64" (15 each)
1	SC75F	47/64" thru 7/8" x 1/64" (10 each)
1	SC75F	57/64" thru 1 1/32" x 1/64" (8 each)
1	SC75F	1 3/64" thru 1 7/64" x 1/64" (8 each)
1	SC75F	1 1/8" thru 1 3/16" x 1/64" (8 each)
1	SC75F	1 13/64" thru 1 17/64" x 1/64" (8 each)
1	SC100F	1 9/32" thru 1 11/32" x 1/64" (8 each)
1	SC100F	1 23/64" thru 1 27/64" x 1/64" (6 each)
1	SC100F	1 7/16" thru 1 1/2" x 1/64" (6 each)
1	SC75F	1 33/64" thru 1 37/64" x 1/64" (3 each)
1	SC75F	1 19/32" thru 1 21/32" x 1/64" (3 each)
1	SC75F	1 43/64" thru 1 47/64" x 1/64" (3 each)
1	SC75F	1 3/4" thru 1 7/8" x 1/32" (3 each)
1	SC75F	1 29/32" thru 2" x 1/32" (2 each)
1	SC125F	drill sleeves - drifts
1	SC100F	misc. reserve drills

TCC-23-■■■□

Milling (14 Drawers)

QTY.	DRW.	STORE
4	SC75F	milling cutters slitting saws
1	SC75F	end mills 1/8" thru 1/2"
1	SC100F	17/32" thru 1"
1	SC100F	1 1/8" thru 1 1/2"
2	SC100F	hog, ball, and other
1	SC100F	key cutters
1	SC125F	slab & face mills
1	SC100F	insertable end mills
1	SC100F	broaches & sleeves
1	SC150F	misc. expansion

TCC-24-■■■□

Reamers & Supplies (14 Drawers)

QTY.	DRW.	STORE
1	SC75F	chucking reamers, st-sk 1/16" thru 17/32" x 1/64"
1	SC75F	9/16" thru 1" x 1/32"
1	SC75F	misc. over 1"
1	SC75F	counter bores and pilots
1	SC75F	spot facers
2	SC75F	assigned cutting tools
1	SC100F	emery sheets
1	SC100F	burrs, stones and mounted points
1	SC100F	fixture components
1	SC100F	allen keys and chuck keys
1	SC125F	hole saws
2	SC150F	stamps, punches, mallets

TCC-25-■■■□

Turning (15 Drawers)

QTY.	DRW.	STORE
2	SC75F	tool holder repair parts, anvils, screws, clamps, shims
2	SC75F	carbide brazed & high speed tools
2	SC75F	s.s. boring bars
2	SC75F	insert tool holders
5	SC100F	carbide inserts
1	SC100F	boring heads, cartridges
1	SC150F	turret tool holders

TCC-26-■■■□

Precision Tools (12 Drawers)

QTY.	DRW.	STORE
2	SC75F	micrometers
1	SC75F	plain plug gages
1	SC75F	thread plug gages
1	SC75F	plain and thread rings
1	SC75F	verniers, gages, indicators, etc.
2	SC100F	verniers, gages, indicators, etc.
2	SC125F	verniers, gages, indicators, etc.
1	SC150F	"V" blocks, dial bore gages
1	SC300F	boxed tool sets

TCC-27-■■■□

Hand Tools (10 Drawers)

QTY.	DRW.	STORE
2	SC75F	files
3	SC100F	hand tools
1	SC150F	grinding wheels to 7" dia.
2	SC150F	misc. supplies
1	SC200F	power tools
1	SC250F	power tools

TCC-28-■■■□

Fasteners (14 Drawers)

QTY.	DRW.	STORE
6	SC75F	fasteners, all types
6	SC100F	fasteners, all types
2	SC150F	fasteners, all types

EASY-ORDER TOOL TRANSPORTER COMBINATIONS

For sheer strength, easy maneuverability and adaptability, Lista's tool transporters set the standard. Lista tool holders and trays are safely and easily transferred from drawers to transporter.

Lista offers a total of six fully equipped standard combinations of transporter units: three B220 series and three B240 series.

For additional parts and accessories, see pages 125, 134 & 135.

Ordering

Please specify the part number for the tool holder size you require. Choose paint color from the color chart on the inside back cover.

B220 Tool Transporters

B220-A Transporters

Comes with 1 stationary shelf with ribbed mat, 1 adjustable shelf with ribbed mat and shelf support clips, and 3 tool holder trays with 3 pairs of mounting brackets.

B220-B Transporters

Comes with 1 stationary shelf with ribbed mat, and 4 tool holder trays with 4 pairs of mounting brackets.

B220-C Transporters

Comes with 1 stationary shelf with ribbed mat, and 5 tool holder trays with 5 pairs of mounting brackets.



B220-A Transporters

PART NO.	TOOL HOLDER	QTY.
B220-A-30	12.880	24
B220-A-40	12.062	21
B220-A-50	12.875	15
B220-A-05	12.890	18
B220-A-HSK50	15.319	24
B220-A-HSK63	15.320	18
B220-A-HSK100	15.336	12



B220-B Transporters

PART NO.	TOOL HOLDER	QTY.
B220-B-30	12.880	32
B220-B-40	12.062	28
B220-B-50	12.875	20
B220-B-HSK50	15.319	32
B220-B-HSK63	15.320	24
B220-B-HSK100	15.336	16



B220-C Transporters

PART NO.	TOOL HOLDER	QTY.
B220-C-30	12.880	40
B220-C-40	12.062	35
B220-C-50	12.875	25
B220-C-HSK50	15.319	40
B220-C-HSK63	15.320	30
B220-C-HSK100	15.336	20



B240 Tool Transporters

B240-A Transporters

Comes with 2 adjustable shelves with ribbed mats and shelf support clips, 2 tool holder trays with 2 pairs of angled mounting brackets and 1 tool frame with 1 pair of transporter frame brackets.



B240-A Transporters

PART NO.	TOOL HOLDER	QTY.
B240-A-30	12.880	48
B240-A-40	12.062	42
B240-A-50	12.875	30
B240-A-05	12.890	36
B240-A-HSK50	15.319	48
B240-A-HSK63	15.320	36
B240-A-HSK100	15.336	24

B240-B Transporters

Comes with 1 adjustable shelf with ribbed mat and shelf support clips, 5 tool holder trays with 5 pairs of angled mounting brackets and 1 tool frame with 1 pair of transporter frame brackets.



B240-B Transporters

PART NO.	TOOL HOLDER	QTY.
B240-B-30	12.880	72
B240-B-40	12.062	63
B240-B-50	12.875	45
B240-B-HSK50	15.319	72
B240-B-HSK63	15.320	54
B240-B-HSK100	15.336	36

B240-C Transporters

Comes with 2 tool holder trays, 2 pairs of angled mounting brackets, and 2 tool frames with 2 pairs of transporter frame brackets.



B240-C Transporters

PART NO.	TOOL HOLDER	QTY.
B240-C-30	12.880	80
B240-C-40	12.062	70
B240-C-50	12.875	50
B240-C-HSK50	15.319	80
B240-C-HSK63	15.320	60
B240-C-HSK100	15.336	40

TOOL TRANSPORTERS

Lista B220 and B240 transporter units serve as the mobile link between all other Lista tool storage system components.

All transporters have the following features:

- Rigid steel frame and tubular steel handle
- Steel sheet side panels slotted at 1" intervals for positioning trays, frames, shelves and other accessories
- 2 fixed and 2 swivel heavy duty 6" x 2" casters with wheel locks, for optimum traction and maneuverability even on irregular surfaces
- 600 lb. capacity per wheel (2400 lb. total)
- Can be safely and easily transported large distances with a fork truck

Transporter Unit B220

This is the smaller of the 2 Lista transporter units. It can be fitted with 3 tool trays in a row, or a frame. Fully equipped Easy-Order transporters are shown on pages 132 -133.



Transporter Unit B220

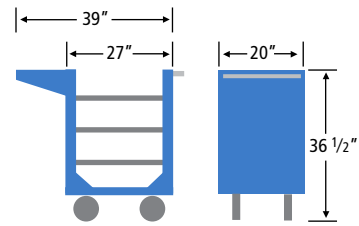

Transporter Unit B240

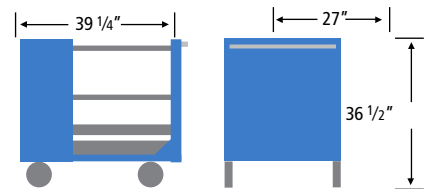

Transporter Unit B240

The larger of the transporter units has a greater capacity and can be fitted with 4 tool trays in a row or a frame. The B240 has an additional front rack for tool trays, adjustable shelves or horizontal supports for long tools. Fully equipped Easy-Order transporters are shown on pages 132 -133.

Tool Tray Mounting Brackets, Pairs

Two types of brackets are available: 1 for horizontal, the other for angled mounting of the TT-1 tool tray on transporters or in Bench Stands. Made of heavy gauge steel with locking pins included. **Color: to match transporter.** Not compatible with TT-1 tool trays sold before May 2003.



Tool Tray Mounting Brackets, Pairs

PART NO.	USE
TTBR-T	straight
TTBR-TA	20° angle

Tool Holder Frame/Brackets

Brackets bolt securely on the perforated sides of the transporter unit in horizontal positions. Tool holder frames fit into vertical slots on the brackets (both required). Color: to match transporter.



Tool Holder Frame/Brackets

Frame PART NO.	USE
TF2736	B220 transporter
TF3636	B240 transporter

Transporter Bracket (pairs)

Transporter Bracket (pairs) PART NO.	USE
TFBR27	B220 transporter
TFBR36	B240 transporter

TOOL TRANSPORTER ACCESSORIES

Lista's broad selection of accessories can convert your basic transporter into a customized tool trolley.

Adjustable Shelf

The adjustable shelf can be mounted on either the B220 or B240 transporter unit. Suitable for measuring and other small tools, each includes a ribbed mat and 4 shelf clips. Color: to match transporter.



Adjustable Shelf

PART NO.	SIZE
NAS23	11 3/4" x 23 1/2"

B220 Stationary Shelf

Attached to the front end of the B220 transporter, this shelf, with its 1" (25mm) lip, is perfect for holding measuring and other small tools. Ribbed mat and fasteners included. Color: to match transporter.



B220 Stationary Shelf

PART NO.	SIZE
NSS22	12" x 19 3/8"

Document Pocket

A compact storage box for technical drawings, documents, etc. that can be fitted to the front or back of either the B220 or B240 transporter unit. Color: gray.



Document Pocket

PART NO.	SIZE
DP-1	14 1/8" W x 1 3/4" D x 7" H



STORAGE WALL

p.138-149



STORAGE WALL FEATURES

The Lista Storage Wall System is packed wall-to-wall with unequalled features and benefits. This unique System's extraordinary flexibility means you get the exact solution that your storage needs demand.

1. **Feature:** Six stackable heights. Storage Wall Systems come in six standard sizes up to 118 1/8" high. They can be arranged as multi-story installations with mezzanines.

Benefit: Maximum use of storage space by using available height

2. **Feature:** Adjustable drawers, shelves and roll-out trays. For your current or changing needs, drawers, shelves and roll-out trays can be combined in any sequence in any section and easily rearranged

Benefit: Total flexibility

3. **Feature:** Roll-out trays. Full extension roll-out trays roll smoothly with their full 440 lb. or 770 lb. load capacities

Benefit: Heavy items are easily accessible

4. **Feature:** Variety of locking systems. Individual sections can be locked for added, specific security

Benefit: Your security requirements can be totally satisfied

5. **Feature:** 100% full extension drawers. Drawers ride smoothly on a unique precision suspension system

Benefit: Full use of all drawer space and easy access to farthest corners

6. **Feature:** Six different full sidewall height drawers. Sidewall and partition height are equal to usable drawer height

Benefit: Full use of cubic volume with no wasted space

7. **Feature:** Hinged drawer handle covers/label holders. Unique handle cover has hinged plastic cover that easily opens and closes to allow labels to be added and changed, while protecting labels from handling, tears and dirt. Drawers and contents can be labeled with free, downloadable Lista Script software.

Benefit: Faster retrieval and easier inventory control

8. **Feature:** Custom compartments. All drawers have partitioning slots on all four sides, and Lista offers a wide variety of partitioning accessories

Benefit: Maximum organization and faster retrieval

SHALLOW DEPTH STORAGE WALL SYSTEM 21 3/4" DEEP



FULL DEPTH STORAGE WALL SYSTEM
27 3/4" DEEP





HOW TO CONFIGURE A STORAGE WALL® SYSTEM

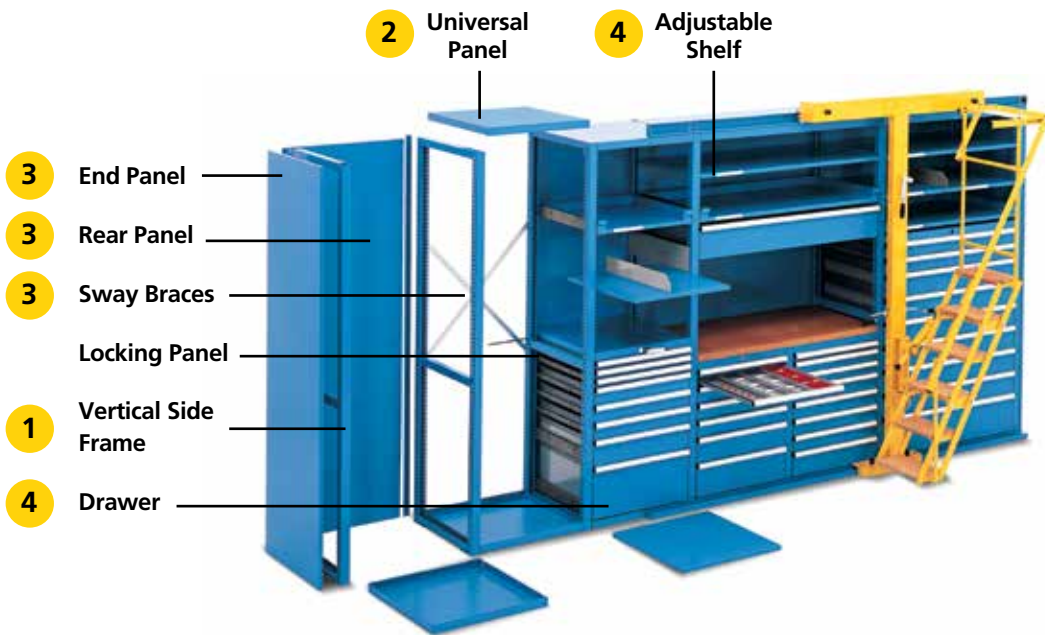

Length of Storage Wall® Systems

To determine actual Storage Wall length, add together the sections you are assembling and add an additional 2". If end panels are used, add 29/32" for each.

SECTION WIDTH	LENGTH BETWEEN SIDE FRAME CTRS.
CL/MP width (27 units)	22 1/16" (561mm)
ST/SC width (36 units)	28 1/8" (714mm)
ES/EW width (45 units)	34 1/8" (867mm)
HS/HW width (54 units)	40 5/32" (1020mm)
MS/MW width (64 units)	46 7/8" (1190mm)
HT/DW width (78 units)	56 1/4" (1428mm)

1. Select Vertical Side Frames.
2. Select universal panels and optional lock system panels.
3. Select rear panel or sway braces and optional end panels.
4. Select drawers, shelves, and roll out trays.
5. Select system options – doors, book cases, etc.
6. Select paint colors.

System frame and panels can be a different color from drawer fronts, but drawer interiors are always gray.

1. **Select Vertical Side Frames** - Heavy duty one-piece vertical uprights with welded horizontal struts. Uprights are slotted at 1" increments for placement of drawers, roll-out trays or shelves.
2. **Select Universal Panels** - Steel sheet universal panels measure 2" (50mm) in height and are fastened to the top and bottom of the vertical side frames to complete each section. Sections with vertical side frames 2200 or greater must have a third intermediate universal panel.
3. **Select Rear Panels or Sway Braces and Optional End Panels** -
 - Rear Panels - Panels are bolted to the vertical side frames to enclose the rear of each section and provide lateral stability.
 - Sway Braces - Used for units without rear panels to provide the necessary lateral stability. Diagonal braces must be fitted at least every fourth section.
 - End Panels. These optional steel sheet panels enclose the ends of the completed units. Hardware included.
4. **Select Drawers Shelves and Roll-Out Trays** - Roll-out trays can be mounted in any sequence or combination with drawers and shelves. Each tray uses the equivalent height of a 100 drawer (100mm high). Trays have full length handles, galvanized insert

panels, and 1 3/4" rear and side retaining walls. Be sure to order trays to match the particular section width and depth you are outfitting.

- Usable depth of tray or shelf is based on system depth and referenced in charts on corresponding sections.
 - Heavy Duty Roll-Out Tray - Weight capacity is 770 lbs. for evenly distributed loads.
 - Adjustable Shelves - Steel shelves can easily be moved at any time and used in any combination or sequence with drawers and roll-out trays. Shelves are 1" (25mm) high.
5. **Select Storage Wall® accessories, doors book cases etc.** -
 - Shelf Dividers - Steel dividers fit over lip of shelf.
 - Shelf End Panels - Steel sheet panel provides side wall for shelves.
 - Frame Top Fill-In Strip - Steel sheet strip, covers top of vertical side frames to create a smooth continuous surface.
 - Ladders can be used with hinged & sliding door sets only with additional Ladder/EXT bracket sold separately. **Not for use on vertical tambour doors.**
 - Hinged Door Sets Max height 2200 - Protect inventory and equipment from dirt and theft with full-height hinged doors.
 - Sliding Door Sets Max height 3000 - Doors move smoothly on ball bearings.
 - Vertical Tambour Doors Max height 2500 - Individual Storage Wall sections can be locked with vertical tambour door. Vertical door rides effortlessly on tracks mounted to the vertical side frames and retracts into a box mounted on the top of the section. The box adds 8" to the height of the unit.
 6. **Select paint colors** - For color chart, see inside back cover.

FULL DEPTH STORAGE WALL® SYSTEM

(27 3/4" deep—705mm)

Full depth Storage Wall sections come in six different widths. Section widths correspond to MP, SC, EW, HW, MW and DW components.

Width center line to center line dimensions of Vertical Side Frames (VSF's)

MP WIDTH (27U)	SC WIDTH (36U)	EW WIDTH (45U)	HW WIDTH (54U)	MW WIDTH (64U)	DW WIDTH (78U)
22 1/16" (561mm)	28 1/8" (714mm)	34 1/8" (867mm)	40 1/8" (1020mm)	46 7/8" (1190mm)	56 1/4" (1428mm)

To determine actual Storage Wall length, add together the sections you are assembling and an additional 2". If your end panels are used, add 29/32" for each.

At any time additional sections can be added, and drawers, roll-out trays and shelves can be easily reconfigured to accommodate growth and changing needs.

Ordering

All Basic components are ordered separately from the charts on the following pages. Be sure to match widths and depths of the drawers, shelves, etc. to the section width and depth you are building. For step-by-step directions for ordering, see page 80–81.

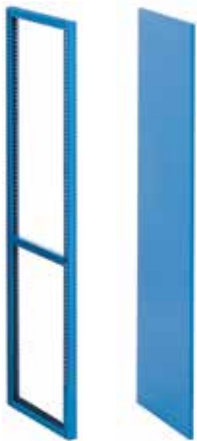

Vertical Side Frame End Panel

Vertical Side Frames (VSF), End Panels (EP) & Inside Panels (IP)

OVERALL SYSTEM HEIGHT	USABLE SYSTEM HEIGHT	1 VSF PART NO.	3 EP PART NO.	IP PART NO.
39 3/8" (1000mm)	35 7/16" (900mm)	VSF1000	EP1000/36U	IP1000/36U
57 1/8" (1450mm)	53 1/8" (1350mm)	VSF1450	EP1450/36U	IP1450/36U
78 3/4" (2000mm)	74 3/4" (1900mm)	VSF2000	EP2000/36U	IP2000/36U
86 5/8" (2200mm)	80 3/4" (2050mm)	VSF2200	EP2200/36U	IP2200/36U
98 7/16" (2500mm)	92 1/2" (2350mm)	VSF2500	EP2500/36U	IP2500/36U
118 1/8" (3000mm)	112 1/4" (2850mm)	VSF3000	EP3000/36U	IP3000/36U



Inside Panel



Universal Panel

Universal Panels (UP), Universal Mounting Panels (UMP) & Adjustable Shelves (AS)

SECTION WIDTH	2 UP PART NO.	2 UMP PART NO.	4 AS PART NO.	USABLE WIDTH FOR UP, UMP & AS	USABLE DEPTH FOR UP, UMP & AS
27U	UP/27U	UP/27U-UM	AS-P/2736U	20" (508mm)	27 1/2" (699mm)
36U	UP/36U	UP/36U-UM	AS-P/36U	26" (661mm)	27 1/2" (699mm)
45U	UP/4536U	UP/4536U-UM	AS-P/4536U	32 1/16" (814mm)	27 1/2" (699mm)
54U	UP/5436U	UP/5436U-UM	AS-P/5436U	38 1/16" (967mm)	27 1/2" (699mm)
64U	UP/64U	UP/64U-UM	AS-P/64U	44 3/4" (1137mm)	27 1/2" (699mm)
78U	UP/78U	UP/78U-UM	AS-P/78U	54 1/8" (1375mm)	27 1/2" (699mm)
Capacities	550 lbs. (250kg)	550 lbs. (250kg)	440 lbs. (200kg)		



Real Panel

3 Rear Panels (RP)

OVERALL SYSTEM HEIGHT	27U WIDE RP PART NO.	36U WIDE RP PART NO.	45U WIDE RP PART NO.	54U WIDE RP PART NO.	64U WIDE RP PART NO.	78U WIDE RP PART NO.
39 3/8" (1000mm)	RP1000/27U	RP1000/36U	RP1000/45U	RP1000/54U	RP1000/64U	RP1000/78U
57 1/8" (1450mm)	RP1450/27U	RP1450/36U	RP1450/45U	RP1450/54U	RP1450/64U	RP1450/78U
78 3/4" (2000mm)	RP2000/27U	RP2000/36U	RP2000/45U	RP2000/54U	RP2000/64U	RP2000/78U
86 5/8" (2200mm)	RP2200/27U	RP2200/36U	RP2200/45U	RP2200/54U	RP2200/64U	RP2200/78U
98 7/16" (2500mm)	RP2500/27U	RP2500/36U	RP2500/45U	RP2500/54U	RP2500/64U	RP2500/78U
118 1/8" (3000mm)	RP3000/27U	RP3000/36U	RP3000/45U	RP3000/54U	RP3000/64U	RP3000/78U

3 Sway Braces (SB)

SB-27U	SB-36U	SB-45U	SB-54U	SB-64U	SB-78U
--------	--------	--------	--------	--------	--------



Sway Braces

FULL DEPTH

See pages 66–75 for dimensional information on drawers

4 Drawers and Trays - Capacity = 440 lbs. (200kg)

USABLE HEIGHT	PART NO.	PART NO.	PART NO.	PART NO.	PART NO.	PART NO.
2.17" (55mm)	MP75F	SC75F	EW75F	HW75F	MW75F	DW75F
3.15" (80mm)	MP100F	SC100F	EW100F	HW100F	MW100F	DW100F
4.13" (105mm)	MP125F	SC125F	EW125F	HW125F	MW125F	DW125F
5.12" (130mm)	MP150F	SC150F	EW150F	HW150F	MW150F	DW150F
6.10" (155mm)	MP175F	SC175F	EW175F	HW175F	MW175F	DW175F
7.09" (180mm)	MP200F	SC200F	EW200F	HW200F	MW200F	DW200F
8.07" (205mm)	MP225F	SC225F	EW225F	HW225F	MW225F	DW225F
9.06" (230mm)	MP250F	SC250F	EW250F	HW250F	MW250F	DW250F
10.04" (255mm)	MP275F	SC275F	EW275F	HW275F	MW275F	DW275F
11.02" (280mm)	MP300F	SC300F	EW300F	HW300F	MW300F	DW300F
12.01" (305mm)	MP325F	SC325F	EW325F	HW325F	MW325F	DW325F
12.99" (330mm)	MP350F	SC350F	EW350F	HW350F	MW350F	DW350F
13.98" (355mm)	MP375F	SC375F	EW375F	HW375F	MW375F	DW375F
14.96" (380mm)	MP400F	SC400F	EW400F	HW400F	MW400F	DW400F
Uses 100 points	MP-TCF	SC-TCF	EW-TCF	HW-TCF	MW-TCF	DW-TCF
Usable Width	18" (457mm)	24" (610mm)	30" (763mm)	36 1/16" (916mm)	42 3/4" (1086mm)	52 1/8" (1324mm)
Usable Depth	24" (610mm)	24" (610mm)	24" (610mm)	24" (610mm)	24" (610mm)	24" (610mm)

4 Heavy Duty Trays - Capacity = 770 lbs. (350kg)

USES 225 POINTS	HDTCF/MP	HDTCF/SC	HDTCF/EW	HDTCF/HW	HDTCF/MW	HDTCF/DW
Usable Width	17" (433mm)	23 1/16" (586mm)	29 1/8" (739mm)	35 1/8" (892mm)	41 1/8" (1045mm)	57 1/4" (1452mm)

Accessories

ITEM	PART NO.	HEIGHT	SPACING
Shelf End Panels	X684/03	6" (150mm)	8" (200mm)
	X684/05	8" (200mm)	10" (250mm)
	X684/07	10" (250mm)	12" (300mm)
Shelf Dividers	SWSD100/36	4" (100mm)	
	SWSD150/36	6" (150mm)	
	SWSD200/36	8" (200mm)	
Self-Adhesive Label Holder	18.926	4 1/8" (105mm)	
	18.927	8 1/4" (201mm)	
	18.929	39 3/8" (1000mm)	
Frame Top Fill-In Strip	X699		
Intermediate Fill-In Strip	X700		



Shelf Ends

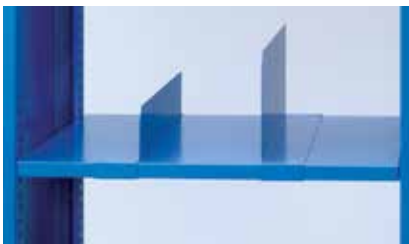

Shelf Dividers



Frame Top Fill-In Strip

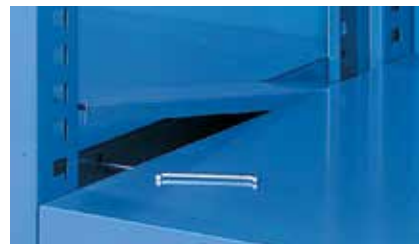

Intermediate Fill-In Strip

SHALLOW DEPTH STORAGE WALL® SYSTEM

(21 3/4" Deep - 502mm)

Full depth Storage Wall sections come in six different widths. Section widths correspond to CL, ST, ES, HS, MS and HT components.

Width center line to center line dimensions of Vertical Side Frames (VSF's)

CL WIDTH (27U)	ST WIDTH (36U)	ES WIDTH (45U)	HS WIDTH (54U)	MS WIDTH (64U)	HT WIDTH (78U)
22 1/16" (561mm)	28 1/8" (714mm)	34 1/8" (867mm)	40 1/8" (1020mm)	46 7/8" (1190mm)	56 1/4" (1428mm)

To determine actual Storage Wall length, add together the sections you are assembling and an additional 2". If your end panels are used, add 29/32" for each.

At any time additional sections can be added, and drawers, roll-out trays and shelves can be easily reconfigured to accommodate growth and changing needs.

Ordering

All Basic components are ordered separately from the charts on the following pages. Be sure to widths and depths of the drawers, shelves, etc. to the section width and depth you are building. For step-by-step directions for ordering, see page 80-81.



Vertical Side Frame End Panel

Vertical Side Frames (VSF), End Panels (EP) & Inside Panels (IP)

OVERALL SYSTEM HEIGHT	USABLE SYSTEM HEIGHT	1 VSF PART NO.	3 EP PART NO.	IP PART NO.
39 3/8" (1000mm)	35 7/16" (900mm)	VSF1000/B255	EP1000/27U	IP1000/27U
57 1/8" (1450mm)	53 1/8" (1350mm)	VSF1450/B255	EP1450/27U	IP1450/27U
78 3/4" (2000mm)	74 3/4" (1900mm)	VSF2000/B255	EP2000/27U	IP2000/27U
86 5/8" (2200mm)	80 3/4" (2050mm)	VSF2200/B255	EP2200/27U	IP2200/27U
98 7/16" (2500mm)	92 1/2" (2350mm)	VSF2500/B255	EP2500/27U	IP2500/27U
118 1/8" (3000mm)	112 1/4" (2850mm)	VSF3000/B255	EP3000/27U	IP3000/27U



Inside Panel



Universal Panel

Universal Panels (UP), Universal Mounting Panels (UMP) & Adjustable Shelves (AS)

SECTION WIDTH	2 UP PART NO.	2 UMP PART NO.	4 AS PART NO.	USABLE WIDTH FOR UP, UMP & AS	USABLE DEPTH FOR UP, UMP & AS
27U	UP/2727U	UP/2727U-UM	AS-P/2727U	20" (508mm)	21 1/2" (546mm)
36U	UP/3627U	UP/3627U-UM	AS-P/3627U	26" (661mm)	21 1/2" (546mm)
45U	UP/4527U	UP/4527U-UM	AS-P/4527U	32 1/16" (814mm)	21 1/2" (546mm)
54U	UP/54U	UP/54U-UM	AS-P/54U	38 1/16" (967mm)	21 1/2" (546mm)
64U	UP/6427U	UP/6427U-UM	AS-P/6427U	44 3/4" (1137mm)	21 1/2" (546mm)
78U	UP/7827U	UP/7827U-UM	AS-P/7827U	54 1/8" (1375mm)	21 1/2" (546mm)
Capacities	550 lbs. (250kg)	550 lbs. (250kg)	440 lbs. (200kg)		



Real Panel

3 Rear Panels (RP)

OVERALL SYSTEM HEIGHT	27U WIDE RP PART NO.	36U WIDE RP PART NO.	45U WIDE RP PART NO.	54U WIDE RP PART NO.	64U WIDE RP PART NO.	78U WIDE RP PART NO.
39 3/8" (1000mm)	RP1000/27U	RP1000/36U	RP1000/45U	RP1000/54U	RP1000/64U	RP1000/78U
57 1/8" (1450mm)	RP1450/27U	RP1450/36U	RP1450/45U	RP1450/54U	RP1450/64U	RP1450/78U
78 3/4" (2000mm)	RP2000/27U	RP2000/36U	RP2000/45U	RP2000/54U	RP2000/64U	RP2000/78U
86 5/8" (2200mm)	RP2200/27U	RP2200/36U	RP2200/45U	RP2200/54U	RP2200/64U	RP2200/78U
98 7/16" (2500mm)	RP2500/27U	RP2500/36U	RP2500/45U	RP2500/54U	RP2500/64U	RP2500/78U
118 1/8" (3000mm)	RP3000/27U	RP3000/36U	RP3000/45U	RP3000/54U	RP3000/64U	RP3000/78U

3 Sway Braces SB54U

SB27U	SB36U	SB45U	SB54U	SB64U	SB78U
-------	-------	-------	-------	-------	-------



Sway Braces

SHALLOW DEPTH

See pages 32–39 for dimensional information on drawers

4 Drawers and Trays - Capacity = 440 lbs. (200kg)

USABLE HEIGHT	PART NO.	PART NO.	PART NO.	PART NO.	PART NO.	PART NO.
2.17" (55mm)	CL75F	ST75F	ES75F	HS75F	MS75F	HT75F
3.15" (80mm)	CL100F	ST100F	ES100F	HS100F	MS100F	HT100F
4.13" (105mm)	CL125F	ST125F	ES125F	HS125F	MS125F	HT125F
5.12" (130mm)	CL150F	ST150F	ES150F	HS150F	MS150F	HT150F
6.10" (155mm)	CL175F	ST175F	ES175F	HS175F	MS175F	HT175F
7.09" (180mm)	CL200F	ST200F	ES200F	HS200F	MS200F	HT200F
8.07" (205mm)	CL225F	ST225F	ES225F	HS225F	MS225F	HT225F
9.06" (230mm)	CL250F	ST250F	ES250F	HS250F	MS250F	HT250F
10.04" (255mm)	CL275F	ST275F	ES275F	HS275F	MS275F	HT275F
11.02" (280mm)	CL300F	ST300F	ES300F	HS300F	MS300F	HT300F
12.01" (305mm)	CL325F	ST325F	ES325F	HS325F	MS325F	HT325F
12.99" (330mm)	CL350F	ST350F	ES350F	HS350F	MS350F	HT350F
13.98" (355mm)	CL375F	ST375F	ES375F	HS375F	MS375F	HT375F
14.96" (380mm)	CL400F	ST400F	ES400F	HS400F	MS400F	HT400F
Uses 100 points	CL-TCF	ST-TCF	ES-TCF	HS-TCF	MS-TCF	HT-TCF
Usable Width	18" (457mm)	24" (610mm)	30" (763mm)	36 1/16" (916mm)	42 3/4" (1086mm)	52 1/8" (1324mm)
Usable Depth	24" (610mm)	24" (610mm)	24" (610mm)	24" (610mm)	24" (610mm)	24" (610mm)

4 Heavy Duty Trays - Capacity = 770 lbs. (350kg)

USES 225 POINTS	HDTCF/CL	HDTCF/ST	HDTCF/ES	HDTCF/HS	HDTCF/MS	HDTCF/HT
Usable Width	17" (433mm)	23 1/16" (586mm)	29 1/8" (739mm)	35 1/8" (892mm)	41 1/8" (1045mm)	57 1/4" (1452mm)

Accessories

ITEM	PART NO.	HEIGHT	SPACING
Shelf End Panels	X612/03	6" (150mm)	8" (200mm)
	X612/05	8" (200mm)	10" (250mm)
	X612/07	10" (250mm)	12" (300mm)
Shelf Dividers	SWSD100/27	4" (100mm)	
	SWSD150/27	6" (150mm)	
	SWSD200/27	8" (200mm)	
Self-Adhesive Label Holder	18.926	4 1/8" (105mm)	
	18.927	8 1/4" (201mm)	
	18.929	39 3/8" (1000mm)	
Frame Top Fill-In Strip	X611		
Intermediate Fill-In Strip	X600		



Shelf Ends



Shelf Dividers



Frame Top Fill-In Strip



Intermediate Fill-In Strip

STORAGE WALL® SYSTEM DOORS

Storage Wall doors come in three different styles. They are Vertical Tambour Door, Sliding Door Sets and Hinged Door Sets. Vertical Tambour and Hinged Doors cover a single Storage Wall section. Sliding Doors cover two sections which must be of equal width (a triple section can be ordered for odd number of bays by contacting your Lista representative). All doors are available in 27U (CL&MP) width (except tambour door), 36U (SC&ST) width, 45U (ES&EW) width, 54U (HS&HW) width, 64U (MS&MW) width and 78U (HT&DW) width. Doors can be added to existing sections to accommodate your changing needs.

Ordering

Hinged and Sliding Door Sets are sold as on as starter and adder concept for running in a series. Vertical Tambour Doors are sold for single section and can be run in a series as well. For additional information please contact your Lista representative.



Vertical Tambour Doors

OVERALL HEIGHT PART NO.

36U WIDE DOOR SET ST&SC WIDTH

69 3/32" (1755mm)	VD1450/36-AL
90 3/4" (2305mm)	VD2000/36-AL
98 5/8" (2505mm)	VD2200/36-AL
110 7/16" (2805mm)	VD2500/36-AL

45U WIDE DOOR SET ES&EW WIDTH

69 3/32" (1755mm)	VD1450/45-AL
90 3/4" (2305mm)	VD2000/45-AL
98 5/8" (2505mm)	VD2200/45-AL
110 7/16" (2805mm)	VD2500/45-AL

54U WIDE DOOR SET HS&HW WIDTH

69 3/32" (1755mm)	VD1450/54-AL
90 3/4" (2305mm)	VD2000/54-AL
98 5/8" (2505mm)	VD2200/54-AL
110 7/16" (2805mm)	VD2500/54-AL

64U WIDE DOOR SET MS&MW WIDTH

69 3/32" (1755mm)	VD1450/64-AL
90 3/4" (2305mm)	VD2000/64-AL
98 5/8" (2505mm)	VD2200/64-AL
110 7/16" (2805mm)	VD2500/64-AL

78U WIDE DOOR SET HT&DW WIDTH

69 3/32" (1755mm)	VD1450/78-AL
90 3/4" (2305mm)	VD2000/78-AL
98 5/8" (2505mm)	VD2200/78-AL
110 7/16" (2805mm)	VD2500/78-AL



Vertical Tambour Door Full Height End Panels

OVERALL HEIGHT	FULL DEPTH 36U	SHALLOW DEPTH 27U
69 3/32" (1755mm)	EP1450/VD-AL	EP1450/VD-AL/B255
90 3/4" (2305mm)	EP2000/VD-AL	EP2000/VD-AL/B255
98 5/8" (2505mm)	EP2200/VD-AL	EP2200/VD-AL/B255
110 7/16" (2805mm)	EP2500/VD-AL	EP2500/VD-AL/B255

For use on left and/or right side of Storage Wall and can only be used at row ends.





Sliding Door Starter and Adder Sets

OVERALL HEIGHT	STARTER SET PART NO.	ADDER SET PART NO.
27U WIDE DOOR SET STANDARD WIDTH (SC) DOOR SET CL&MP WIDTH		
79 1/8" (2010mm)	SD2000/27-S	SD2000/27-A
87" (2210mm)	SD2200/27-S	SD2200/27-A
98 13/16" (2510mm)	SD2500/27-S	SD2500/27-A
118 1/2" (3010mm)	SD3000/27-S	SD3000/27-A
36U WIDE DOOR SET ST&SC WIDTH		
79 1/8" (2010mm)	SD2000/36-S	SD2000/36-A
87" (2210mm)	SD2200/36-S	SD2200/36-A
98 13/16" (2510mm)	SD2500/36-S	SD2500/36-A
118 1/2" (3010mm)	SD3000/36-S	SD3000/36-A
45U WIDE DOOR SET STANDARD WIDTH (SC) DOOR SET ES&EW WIDTH		
79 1/8" (2010mm)	SD2000/45-S	SD2000/45-A
87" (2210mm)	SD2200/45-S	SD2200/45-A
98 13/16" (2510mm)	SD2500/45-S	SD2500/45-A
118 1/2" (3010mm)	SD3000/45-S	SD3000/45-A
54U WIDE DOOR SET HS&HW WIDTH		
79 1/8" (2010mm)	SD2000/54-S	SD2000/54-A
87" (2210mm)	SD2200/54-S	SD2200/54-A
98 13/16" (2510mm)	SD2500/54-S	SD2500/54-A
118 1/2" (3010mm)	SD3000/54-S	SD3000/54-A
64U WIDE DOOR SET MS&MW WIDTH		
79 1/8" (2010mm)	SD2000/64-S	SD2000/64-A
87" (2210mm)	SD2200/64-S	SD2200/64-A
98 13/16" (2510mm)	SD2500/64-S	SD2500/64-A
118 1/2" (3010mm)	SD3000/64-S	SD3000/64-A
78U WIDE DOOR SET HT&DW WIDTH		
79 1/8" (2010mm)	SD2000/78-S	SD2000/78-A
87" (2210mm)	SD2200/78-S	SD2200/78-A
98 13/16" (2510mm)	SD2500/78-S	SD2500/78-A
118 1/2" (3010mm)	SD3000/78-S	SD3000/78-A



Hinged Door Starter and Adder Sets

OVERALL HEIGHT	STARTER SET PART NO.	ADDER SET PART NO.
27U WIDE DOOR SET MP-WIDTH (MP)		
78 3/4" (2000mm)	DHD2000/27SW-S	DHD2000/27SW-A
86 5/8" (2200mm)	DHD2200/27SW-S	DHD2200/27SW-A
36U WIDE DOOR SET STANDARD WIDTH (SC)		
78 3/4" (2000mm)	DHD2000/36SW-S	DHD2000/36SW-A
86 5/8" (2200mm)	DHD2200/36SW-S	DHD2200/36SW-A
45U WIDE DOOR SET WIDTH (SC)		
78 3/4" (2000mm)	DHD2000/45SW-S	DHD2000/45SW-A
86 5/8" (2200mm)	DHD2200/45SW-S	DHD2200/45SW-A
54U WIDE DOOR SET HS-WIDTH WIDTH (HS)		
78 3/4" (2000mm)	DHD2000/54SW-S	DHD2000/54SW-A
86 5/8" (2200mm)	DHD2200/54SW-S	DHD2200/54SW-A27U
64U WIDE DOOR SET MID-WIDTH (MW)		
78 3/4" (2000mm)	DHD2000/64SW-S	DHD2000/64SW-A
86 5/8" (2200mm)	DHD2200/64SW-S	DHD2200/64SW-A
78U WIDE DOOR SET DOUBLE WIDTH (DW)		
78 3/4" (2000mm)	DHD2000/78SW-S	DHD2000/78SW-A
86 5/8" (2200mm)	DHD2200/78SW-S	DHD2200/78SW-A

STORAGE WALL® DRAWER LOCKING SYSTEMS

For a variety of security needs, Lista offers individual, keyed-alike or master key locking systems for drawer sections. If you wish to lock and secure sections made up of a combination of drawers, roll-out trays and/or shelves, choose from the doors shown on pages 146-147.



Lock Systems

For locking a partial height section of drawers. Locks all drawers located below the lock.

PART NO.	DRAWER SECTION HEIGHT
SWLK300-■	11 ¾" (300mm)
SWLK600-■	23 ⅞" (600mm)
SWLK750-■	29 ⅞" (750mm)
SWLK900-■	35 ⅞" (900mm)
SWLK1050-■	41 ⅞" (1050mm)
SWLK1225-■	48 ¼" (1225mm)
SWLK1350-■	53 ⅞" (1350mm)
SWLK1525-■	60" (1525mm)

How to order a lock system

1. Select the appropriate size and type of panels needed to match the Storage Wall section you are building. See the illustrations to the right to find the panels needed for the configuration you have chosen (partial or full height section).

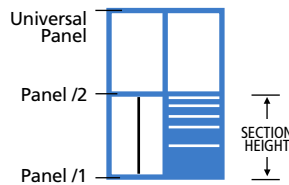

2. Select the appropriate lock system based on the configuration you have chosen (partial or full height section).

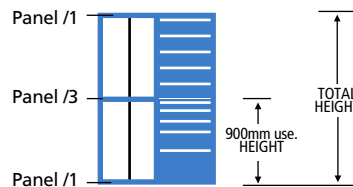

3. ■ Select lock type.

- RG = individual
- KA = keyed-alike
- MA = master

EXAMPLE: to lock a 2200 height Standard Width (36 unit wide) Storage Wall section containing a 900 height group of drawers below the lock and a 1300 height group of drawers above the lock with an individual lock, you would need to order (1) **SWLP3636/1** panel at the bottom, (1) **SWLP3636/2** panel at the top and (1) **SWLP3636/3** panel at the center, and an **SWLK2200-RG** lock system.

Lock Systems for Full Height Drawer Section

For Storage Wall section that contains only drawers top-to-bottom. Locks all drawers located above and below the lock. **Lower section must be 900 height.**

PART NO.	STORAGE WALL TOTAL HT.
SWLK2000-■	74 ¾" (1900mm)
SWLK2200-■	80 ¾" (2050mm)
SWLK2500-■	92 ½" (2350mm)
SWLK3000-■	112 ¼" (2850mm)

FULL DEPTH

SECTION WIDTH	TOP/BOTTOM PANEL PART NO.	TOP (W/HOLE) PART NO.	INTERMEDIATE (W/HOLE) PANEL PART NO.	USABLE WIDTH		LOAD CAPACITY
				INCHES	MM'S	
27U	SWLP2736/1	SWLP2736/2	SWLP2736/3	20.0	508	440 lbs.
36U	SWLP3636/1	SWLP3636/2	SWLP3636/3	26.0	661	440 lbs.
45U	SWLP4536/1	SWLP4536/2	SWLP4536/3	32.0	814	440 lbs.
54U	SWLP5436/1	SWLP5436/2	SWLP5436/3	38.1	967	440 lbs.
64U	SWLP6436/1	SWLP6436/2	SWLP6436/3	44.8	1137	440 lbs.
78U	SWLP7836/1	SWLP7836/2	SWLP7836/3	54.1	1375	440 lbs.

SHALLOW DEPTH

SECTION WIDTH	TOP/BOTTOM PANEL PART NO.	TOP (W/HOLE) PART NO.	INTERMEDIATE (W/HOLE) PANEL PART NO.	USABLE WIDTH		LOAD CAPACITY
				INCHES	MM'S	
27U	SWLP2727/1	SWLP2727/2	SWLP2727/3	20.0	508	440 lbs.
36U	SWLP3627/1	SWLP3627/2	SWLP3627/3	26.0	661	440 lbs.
45U	SWLP4527/1	SWLP4527/2	SWLP4527/3	32.0	814	440 lbs.
54U	SWLP5427/1	SWLP5427/2	SWLP5427/3	38.1	967	440 lbs.
64U	SWLP6427/1	SWLP6427/2	SWLP6427/3	44.8	1137	440 lbs.
78U	SWLP7827/1	SWLP7827/2	SWLP7827/3	54.1	1375	440 lbs.

STORAGE WALL® BOOKCASES & COUNTER TOPS

These offerings make your Storage Wall System even more versatile. The bookcase and counter top are available for both full depth and shallow depth Storage Wall Systems.

Bookcases

Overhead bookcase offers quick access to reference materials and manuals. Bookcase is 12 5/8" deep, with a useable depth of 11 7/8". Color: to match unit.

Butcher Block Counter Tops

Counter style worktop is 1 3/4" thick butcher block hardwood. Mounts on top of universal panel with mounting holes.



Bookcases

PART NO.	FOR USE WITH	USE. WIDTH
BC27U	full and shallow depth	19 1/2"
BC36U	full and shallow depth	25 5/16"
BC45U	full and shallow depth	31 5/16"
BC54U	full and shallow depth	37 5/16"
BC64U	full and shallow depth	44 3/8"
BC78U*	full and shallow depth	54"

*for (1) 78U or (2) 36U

Butcher Block Counter Tops

PART NO.	FOR USE WITH
BCT/2736U	20.0"W x 27.8"D
BCT/2727U	20.0"W x 21.7"D
BCT/3636U	26.0"W x 27.8"D
BCT/3627U	26.0"W x 21.7"D
BCT/4536U	32.0"W x 27.8"D
BCT/4527U	32.0"W x 21.7"D
BCT/5436U	38.0"W x 27.8"D
BCT/5427U	38.0"W x 21.7"D
BCT/6436U	44.75"W x 27.8"D
BCT/6427U	44.75"W x 21.7"D
BCT/7836U	54.1"W x 27.8"D
BCT/7827U	54.1"W x 21.7"D



SPECIALTY STORAGE

p.152-159



ROW 24

ROW 24

ROW 35

ROW 22

TRANSFORM SHELVING INTO A HIGH-DENSITY STORAGE SOLUTION



Stop storing air!

- Replace inefficient shelving as your only storage solution
- Increase storage capacity by as much as **50% or more**
- Improve retrieval time of key parts
- Upgrade to a high-density storage solution for a fraction of the cost of replacing your existing shelving

Increase storage capacity by **as much as 50% or more** by storing smaller items in Shelf Converter® System drawers. Or use your space savings to reclaim needed floor space.

Please contact your Lista representative for more information about the new shelf converter storage solution.

Unique frame system mounts easily to shelving uprights and guarantees smooth drawer functioning

Shelf Converter drawers extend fully for easy access to the furthest corners

Drawers are recessed to prevent clothing from snagging

Small items stored in drawers are easier to locate, easier to pick, and easier to inventory



Store bulky items on your existing shelves

Drawers can be labeled with our unique hinged handle covers and Lista Script software

Drawers have a weight capacity of 200 lbs or 400 lbs. each (3" drawer as only 200lb capacity)

Roll-out tray allows easy access to large, bulky items

SHELF CONVERTER® SYSTEM FEATURES

Key features

- **High density:** With Lista® drawers, you use the full cubic capacity of your storage space.
- **Drawer subdividing system:** Lista® extensive selection of drawer partitioning accessories allows you to create compartments that exactly fit what you're storing.
- **400lb or 200lb full extension drawers:** Lista® drawers stand up to the challenge of even the heaviest storage needs,* holding up to 440 lbs (3" drawer as only 200lb capacity) per drawer, even when fully extended.
- **The perfect solution for retrofitting into existing industrial shelving:** Fits a number of standard shelving brands, including Metalware, Penco Clipper, Rousseau Spider, Tennsco Q-Line and Western Pacific Deluxe.
- **Right-sized storage:** Store small-to-medium sized items in drawers, large bulky items on shelves.
- **Easy installation:** Just attach our unique frame system to your shelving uprights, insert drawer tracks and pop in the drawers.
- **Expandability:** As your storage needs change, the Shelf Converter® System can be removed and re-installed, or added to.
- **Drawer labeling system:** Using our unique hinged drawer handles and free Lista® Script software, you always know where everything is.
- **Ideal for a number of industries and uses:** The perfect solution in a wide range of manufacturing settings, maintenance and repair operations and parts cribs, as well as a lower-cost retrofit for automotive parts departments.

*Do not exceed the maximum storage capacity of your shelving. If total drawer loads for a Shelf Converter® unit will exceed.

Shelf Converter® Sizes

WIDTHS	DEPTHS	DRAWER HEIGHTS
30"	18"	3"
36"	24"	4"
42"		5"
48"		6"
		7"
		8"

Drawer Capacity

200LB	200LB OR 400LB
3"	4"
	5"
	6"
	7"
	8"
	Trays



With traditional shelf storage (left side), you end up storing a lot of air. Smaller items make poor use of cubic space when stored on shelves, and are difficult to locate and keep track of. With the Shelf Converter® System (right side), you can store small-to-medium sized items in high-density drawers and larger items on shelves, where they belong.



Compare the disorganized, inefficient storage in this auto dealership parts department (left) with organized storage using the Shelf Converter® System of shelving drawer inserts (right).

NOTE: Lista does not recommend installing a Shelf Converter unit in a stand-alone shelving section.

COMPUTER CABINET FEATURES AND OPTIONS

Lista's computer cabinet is packed with powerful features

- Air intake fan with guard and fine filter (replaceable from the outside) creates positive pressure, eliminates dust and possible damage to electrical components
- Large keyboard tray with hinged front gate allows space for mouse
- Monitor door has clear plexiglas window for visibility and protection
- Retractable door option for convenient access to touch screen monitors
- Monitor and lower door locks are keyed alike
- Lower sections provide secure storage for CPU and printer—printer tray extends for ease of access
- Surge suppressor protects equipment and hardware using advanced circuitry, eliminates dangers caused by surges, spikes and EMI/RFI noise
- 6 1/2" wide rear access panel for ease of connection and routing of cables
- Several base options available
- Optional fan for lower section of cabinet
- Optional exterior folding shelf for additional storage



A technician accesses a Lista computer cabinet which houses a diagnostic computer. The computer cabinet's mobility allows it to be relocated within the department as needed.



FRONT

Model CWS1350 shown with optional mobile base



BACK

COMPUTER CABINET EASY-ORDER COMBINATION AND ACCESSORIES

Easy-Order Computer Cabinet Combination

Easy-Order computer cabinet comes with:

- Hinged upper section door with plexiglas window (opening for monitor is 24" wide x 19 1/2" high x 24" deep)
- Double hinged lower section doors
- Keyboard tray with hinged front gate
- Printer tray
- Bottom shelf
- Back access panel
- Cord channel/outlet strip
- Upper fan

Other options and accessories to augment cabinets must be ordered from the charts to the right.

28 1/4" WIDE X 57 1/8" HIGH X 29 1/2" DEEP
PART NO.

CWS1350-■■■□



A mobile computer cabinet is paired with a mobile industrial workbench in Toyota Racing Development's machine shop.

How to order an Easy-Order Computer Cabinet

1. Select Easy-Order Computer Cabinet combination.

2. ■ Select base type.

- NB = none
- FT = fork truck
- 2FB = 2" frame base
- 4FB = 4" frame base
- 6FB = 6" frame base
- 4B = 4" mobile base
- 6B = 6" mobile base
- 2LB = 2" leveling base
- 4LB = 4" leveling base
- 6LB = 6" leveling base

For base descriptions, see SC cabinet bases on page 42-65.

3. ■ Select lock type.

- RG = individual
- KA = keyed-alike
- MA = master

For additional lock options, see page 82-83.

4. □ Select paint color. For color chart, see inside back cover.

EXAMPLE: to order a CWS1350 cabinet with a fork truck base, an individual lock and Bright Blue paint, the part number would be **CWS1350-FTRGBB**.



Retractable Door

Door slides out and back for access to monitor. Provides convenient access to touch screens. Reduces opening height by 2 1/2".

PART NO.
RD525/SC-P

Electrical and Fan Options

PART NO.	DESCRIPTION
FAN-CWS	second fan for lower section
CWS-OUT/36U	second outlet strip and bracket



Folding Shelves

Shelf can be mounted on either the left or right side of cabinet. 50 lb. maximum capacity. Shelf is 15" wide x 28 1/2" deep.

PART NO.	MOUNTS TO
FS-36DX15-L	left side
FS-36DX15-R	right side

Mobile Handles

Handles are mounted to either the side or front of cabinet. Cabinets are pre-drilled and handles are mounted in the field. Hardware included. For descriptions, see page 108.

PART NO.	DESCRIPTION
HSG-HNDL/36	side push metal handle
MHAN	front push plastic handles (pair)

CONTROL STATIONS

The secure, durable and flexible Lista Control Station is ideal for meeting the needs of a wide array of manufacturing floor applications:

- Quality station or foreman’s workstation on the manufacturing floor
- Gauging station on an automotive assembly line
- Line supervisor’s station in an assembly plant
- Shipping dock

This unique combination of a workbench, bookshelf and cabinet offers a private, protected, lockable workspace with organized storage and ready access to manuals and tools. The work area features a pegboard and one or two bookshelves. The Control Station is available in two heights – 91 ½” or 99 ¾” tall.

The Control Station is available in all Lista paint colors (see inside back cover); the tambour door is available in dove gray only.



The Control Station features a slide-down tambour door that can be locked at the desktop or at the base of the station.



Model CS2200/5

EASY-ORDER CONTROL STATION COMBINATIONS

The Control Station is available in 3 Easy-Order configurations. These 3 models are designed to accommodate the broadest range of Control Station sizes and features.

Basic Control Station

60 1/4" wide x 29 3/4" deep

Equipped as shown with lockable tambour door, bookshelf, pegboard, fluorescent light and 1 3/4" thick butcher block counter top. A variety of optional stationary and mobile cabinets can be placed under the counter top; see the cabinet section of this catalog to select the cabinet size that best fits your needs.

Control Station – Configurable

60 1/4" wide x 29 3/4" deep

Equipped as shown with lockable tambour door, bookshelf, pegboard, fluorescent light, 1 3/4" thick butcher block counter top and a 750 height framework for SC Standard Width drawers. To select drawers for the framework, see page 69-71.

Control Station – Pre-configured

60 1/4" wide x 29 3/4" deep

Equipped as shown with lockable tambour door, bookshelf, pegboard, fluorescent light, 1 3/4" thick butcher block counter top and a 750 height Standard Width framework, containing 1 each of the following height drawers:

- 75F (2")
- 100F (3")
- 125F (4")
- 150F (5")
- 300F-FFH (11") drawer with a letter-size file folder hanger (see photo to right).

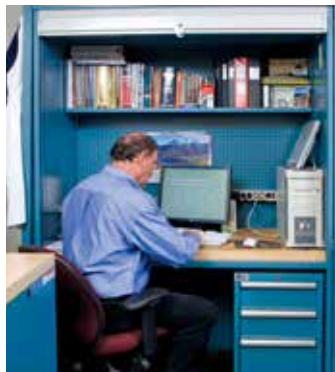
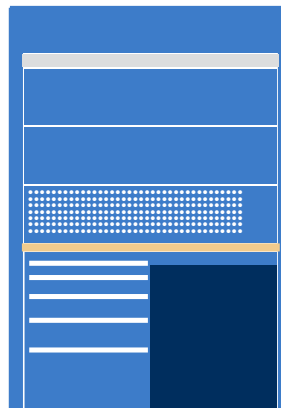
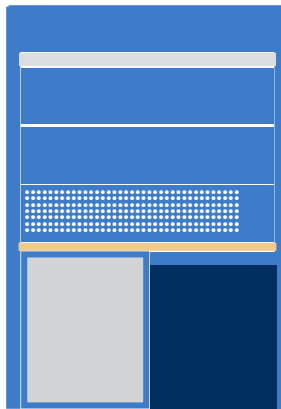
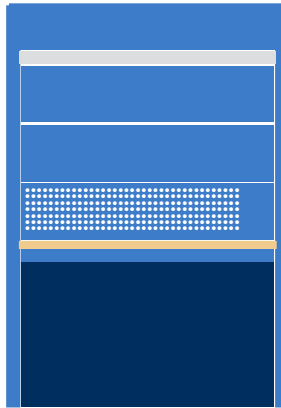

Basic Control Station

PART NO.	HEIGHT	NO. OF BKSHV.	PEGBOARD HEIGHT
CS2000-AL	91 1/2"	1	18"
CS2200-AL	99 3/8"	2	15"

WITHOUT TAMBOUR DOOR

CS2000-ND	78 3/4"	1	18"
CS2200-ND	86 5/8"	2	15"

Control Station – Configurable

PART NO.	HEIGHT	NO. OF BKSHV.	PEGBOARD HEIGHT
CS2000/1-AL	91 1/2"	1	18"
CS2200/1-AL	99 3/8"	2	15"

WITHOUT TAMBOUR DOOR

CS2000/1-ND	78 3/4"	1	18"
CS2200/1-ND	86 5/8"	2	15"

Control Station – Pre-configured

PART NO.	HEIGHT	NO. OF BKSHV.	PEGBOARD HEIGHT
CS2000/5-AL	91 1/2"	1	18"
CS2200/5-AL	99 3/8"	2	15"

WITHOUT TAMBOUR DOOR

CS2000/5-ND	78 3/4"	1	18"
CS2200/5-ND	86 5/8"	2	15"



The Control Station's work area offers protection from dust and dirt for your expensive computer equipment, instruments and gauges. The Station's pegboard and bookshelves let you keep manuals and tools close at hand. The worksurface height at the butcher block top is 35 1/4".



The Control Station's storage cabinets can be outfitted with modular drawers in a variety of sizes. Drawers can be configured for compartmentalized storage of tools and parts, or to hold hanging files.

SINK CABINETS

Sink cabinet includes a cabinet housing, flush door or double flush doors, a bottom shelf, and cut-outs for sink and plumbing. Does not include counter top or sink basin.

How to order an Easy-Order Sink Cabinet

1. Select a cabinet from the charts to the right.
2. ■ Select base type.
 - FT = fork truck
 - PT = pallet truck
 - 2FB = 2" frame
 - 2LB = 2" leveling base
 - 4LB = 4" leveling base
 - 6LB = 6" leveling base
3. ■ Select lock type.
 - RG = individual
 - KA = keyed-alike
 - MA = master

For additional lock options, see pages 82-83.
4. □ Select paint color. For color chart, see inside back cover.

EXAMPLE: to order an MW750SINK sink cabinet with a fork truck base, an individual lock and Bright Blue paint, the part number would be **MW750SINK-FTRGBB**.



Sink Cabinets – Flush Door

PART NO.	HOUSING	HEIGHT*
28 1/4" WIDE X 28 1/2" DEEP		
SC750SINK-■□□	SC	33 1/2"
SC900SINK-■□□	SC	39 3/8"

28 1/4" WIDE X 22 1/2" DEEP		
ST750SINK-■□□	ST	33 1/2"
ST900SINK-■□□	ST	39 3/8"

*does not include height of counter top or base

Sink Cabinets – Double Flush Door

PART NO.	HOUSING	HEIGHT*
47" WIDE X 28 1/2" DEEP		
MW750SINK-■□□	MW	33 1/2"
MW900SINK-■□□	MW	39 3/8"

56 1/2" WIDE X 28 1/2" DEEP		
DW750SINK-■□□	DW	33 1/2"
DW900SINK-■□□	DW	39 3/8"

40 1/4" WIDE X 22 1/2" DEEP		
HS750SINK-■□□	HS	33 1/2"
HS900SINK-■□□	HS	39 3/8"

*does not include height of counter top or base

FILE DRAWER CABINET

File drawer cabinet housing is 16 7/8" (428mm) wide x 28 1/2" (725mm) deep. Drawers are full extension with 165 lb. (75kg) maximum load capacity. For letter-sized files only.

How to order an Easy-Order File Drawer Cabinet

1. Select file drawer cabinet combination.
2. ■ Select base type.
 - NB = none
 - 2FB = 2" frame base
 - 4FB = 4" frame base
 - 2LB = 2" leveling base
 - 4LB = 4" leveling base
3. ■ Select lock type.
 - NL = none
 - RG = individual
 - KA = keyed-alike
 - MA = master
 - KP = keypad

For additional lock options, see pages 82-83.
4. □ Select paint color. For color chart, see inside back cover.

EXAMPLE: to order an NW0900-0301N file cabinet with a 2" frame base, an individual lock and Bright Blue paint, the part number would be **NW0900-0301N-2FBRGBB**.

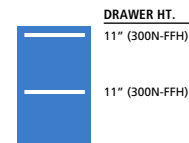

PART NO.	DRWS.	HT.
NW0600-0201N-■□□	2	27 1/2"

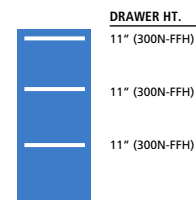

PART NO.	DRWS.	HT.
NW0900-0301N-■□□	3	39 3/8"

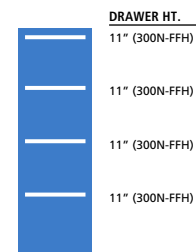

PART NO.	DRWS.	HT.
NW1200-0401N-■□□	4	52 3/16"

MEZZANINES AND STACKED CABINETS

Lista Storage Wall® Systems (see pages 138-149) and stacked cabinets serve as ideal mezzanine supports. Our technical support and design team can help you determine the option that best suits your space and needs.

Stacked cabinets

With their all-steel construction, Lista cabinets can be stacked to help you maximize your floor space. You can rapidly re-arrange storage layouts to suit your changing needs.



When Osram Sylvania needed to relocate a 3,300 square foot stockroom into a 1,500 square foot space, a mezzanine was the answer. The company combined new Lista cabinet housings and drawers with existing Lista cabinets to create this space- and money-saving solution.



To add a second level of storage space without adding an additional floor to their maintenance area, Gulf States Paper Corp. utilizes a mezzanine system. The system is home to 49 sets of stacked cabinets.



Storage Walls Systems and stacked cabinets lend themselves to a variety of mezzanine configurations that take advantage of all available height. Examples pictured here are (clockwise from top) installations at a utility maintenance department, an aircraft repair facility and an automotive manufacturing plant.

WORKBENCHES

p.162-259



INDUSTRIAL WORKBENCH FEATURES

Rugged. Durable. Built to handle the harshest work environments. Lista's industrial workbenches feature flexible standard components and can be cost-effectively custom configured to meet the specific needs of your application.

Feature: Wide choice of above-worksurface accessories

Create task-specific configurations

Benefit: Greater productivity and efficiency

Feature: Variety of worksurfaces

Durable tops come in a variety of sizes

Benefit: Worksurface always appropriate to application

Feature: Removable lock core

Locks can be replaced in the field

Benefit: Greater security, easy replacement

Feature: Ergonomic handles

When drawers are closed, handles are flush with housing so nothing protrudes. Drawer handles are located at top of drawer.

Benefit: Improves safety, appearance and ergonomics

Feature: Customizable drawer compartments

A wide variety of drawer accessories for maximum partitioning flexibility

Benefit: Better organization, faster retrieval

Feature: Choice of pedestal sizes and styles

Wide variety of workbench support options

Benefit: Customized to your needs

Feature: Heavy-duty welded leg

One-piece leg with bottom hole for leveling glides

Benefit: Provides support for heavy-duty applications

Feature: Mobility

Cabinets and legs are available with casters

Benefit: Work areas can easily be reconfigured, components can be simply moved out & back for easier, more efficient and effective cleaning of the area





PRECONFIGURED INDUSTRIAL WORKBENCHES

Preconfigured workbenches include MP Width (22 3/16" wide) cabinet pedestals (see pages 42–51 for description).

How to order an Preconfigured Industrial Workbench

1. Select Preconfigured workbench.
2. Select worksurface style. See pages 171–172 for descriptions.

LTS = Lista Top
GLS = Galvanized steel
PLS = Plastic laminate
BTS = Butcher block

All worksurfaces have a standard square edge and are 30" deep.

3. Select worksurface size.

4830 = 48" long x 30" deep
6030 = 60" long x 30" deep
7230 = 72" long x 30" deep

4. Select paint color. For color chart, see inside back cover.

EXAMPLE: to order a WB1201 workbench with a 72" long plastic laminate worksurface and Bright Blue paint, the part number would be **WB1201-PLS7230BB**.

5. Select cabinet pedestals (for WB03xx and WB06xx configurations). For Preconfigured cabinet pedestals, see pages 42–51 for Narrow Width cabinets and MP Width Cabinets.

EXAMPLE (CUSTOMER-SPECIFIED CABINETS): to order a WB0300 workbench with a 72" long plastic laminate worksurface, and an MP0750-0601FA cabinet pedestal with Bright Blue paint, the workbench part number would be **WB0300-PLS7230BB**, and the cabinet part number would be **MP0750-0601FA-NBRGGB**.

Workbenches with 2 Lista Legs

Overall bench height including worksurface is 35 1/4". Includes:

- 2 Lista Legs (legs are 33 1/2" high)
- 1 stringer



PART NO.
WB1000-



PART NO. INCLUDES
WB1001- back stop and end stops



PART NO. INCLUDES
WB1002- stationary riser shelf with back stop + full rear panel workbench end stops



PART NO. INCLUDES
WB1003- 12" adjustable riser shelf with back stop workbench back stop and end stops

Workbenches with 2 Lista Legs and 1 Drawer

Overall bench height including worksurface is 35 1/4". Includes:

- 2 Lista Legs (legs are 33 1/2" high)
- 1 stringer
- 1 WBHC150-1 hanging cabinet



PART NO.
WB1100-



PART NO. INCLUDES
WB1101- back stop and end stops



PART NO. INCLUDES
WB1102- stationary riser shelf with back stop + full rear panel workbench end stops



PART NO. INCLUDES
WB1103- 12" adjustable riser shelf with back stop workbench back stop and end stops

Workbenches with 1 Lista Leg and 1 Cabinet

Overall bench height including worksurface is 35 1/4". Includes:

- 1 Lista Leg (leg is 33 1/2" high)
- 1 stringer
- 1 MP0600-0402FA-F6RG cabinet



PART NO.
WB1200-



PART NO. INCLUDES
WB1201- back stop and end stops



PART NO. INCLUDES
WB1202- stationary riser shelf with
back stop + full rear panel
workbench end stops



PART NO. INCLUDES
WB1203- 12" adjustable riser shelf
with back stop
workbench back stop and
end stops

Workbenches with 1 Leg and 1 Customer-Specified Cabinet

Overall bench height including worksurface is 35 1/4". Includes:

- 1 Lista Leg (leg is 33 1/2" high)
 - 1 stringer
 - cabinet pedestal chosen by customer
- * See page 42-51 for MP & NW cabinets

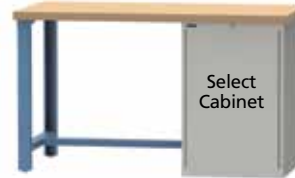

PART NO.
WB0300-



PART NO. INCLUDES
WB0301- back stop and end stops



PART NO. INCLUDES
WB0302- stationary riser shelf with
back stop + full rear panel
workbench end stops



PART NO. INCLUDES
WB0303- 12" adjustable riser shelf
with back stop
workbench back stop and
end stops

Workbenches with 2 Cabinets

Overall bench height including worksurface is 35 1/4". Includes:

- 1 MP0600-0402FA-F6KA cabinet*
 - 1 MP0600-0202FA-F6KA cabinet*
- *includes keyed-alike locks



PART NO.
WB1400-■■■

Overall bench height including worksurface is 35 1/4". Includes:

- 1 MP0600-0501FA-F6KA cabinet*
 - 1 MP0600-0204D-F6KA cabinet*
- *includes keyed-alike locks



PART NO.
WB1500-■■■

Workbenches with 2 Customer-Specified Cabinets

Overall bench height including worksurface is 35 1/4". Includes:

- 2 cabinet pedestals chosen by customer



PART NO.
WB0600-■■■



PART NO. **INCLUDES**
WB1401-■■■ back stop and end stops



PART NO. **INCLUDES**
WB1501-■■■ back stop and end stops



PART NO. **INCLUDES**
WB0601-■■■ back stop and end stops



PART NO. **INCLUDES**
WB1402-■■■ stationary riser shelf with
back stop + full rear panel
workbench end stops



PART NO. **INCLUDES**
WB1502-■■■ stationary riser shelf with
back stop + full rear panel
workbench end stops



PART NO. **INCLUDES**
WB0602-■■■ stationary riser shelf with
back stop + full rear panel
workbench end stops



PART NO. **INCLUDES**
WB1403-■■■ 12" adjustable riser shelf
with back stop
workbench back stop and
end stops



PART NO. **INCLUDES**
WB1503-■■■ 12" adjustable riser shelf
with back stop
workbench back stop and
end stops



PART NO. **INCLUDES**
WB0603-■■■ 12" adjustable riser shelf
w/back stop
workbench back stop and
end stops

PRECONFIGURED INDUSTRIAL MOBILE WORKBENCHES

Preconfigured mobile workbenches include MP Width (22 3/16" wide) cabinet pedestal (see pages 42–51 for description). They include 2 fixed and 2 swivel 6" x 2" casters with wheel locks.

How to order an Preconfigured Industrial Mobile Workbench

1. Select Preconfigured workbench.

2. ■ Select worksurface style.

See pages 171–172 for descriptions.

- LTS** = Lista Top
- GLS** = Galvanized steel
- PLS** = Plastic laminate
- BTS** = Butcher block

All worksurfaces have a standard square edge and are 30" deep.

3. ■ Select worksurface size.

- 4830** = 48" long x 30" deep
- 6030** = 60" long x 30" deep
- 7230** = 72" long x 30" deep

4. □ Select paint color. For color chart, see inside back cover.

EXAMPLE: to order a WB2201 workbench with a 72" long plastic laminate worksurface and Bright Blue paint, the part number would be **WB2201-PLS7230BB**.

Mobile Workbenches with 2 Lista Mobile Legs

Overall bench height including worksurface is 35 1/4". Includes:

- 2 Lista Mobile Legs (legs are 33 1/2" high)
- 1 stringer



PART NO.
WB2000- ■ □ □



PART NO. INCLUDES
WB2001- ■ □ □ back stop and end stops



PART NO. INCLUDES
WB2002- ■ □ □ stationary riser shelf with
back stop + full rear panel
workbench end stops



PART NO. INCLUDES
WB2003- ■ □ □ 12" adjustable riser shelf
with back stop
workbench back stop and
end stops

Mobile Workbenches with 2 Mobile Legs and 1 Drawer

Overall bench height including worksurface is 35 1/4". Includes:

- 2 Lista Mobile Legs (legs are 33 1/2" high)
- 1 stringer
- 1 WBHC150-1 hanging cabinet



PART NO.
WB2100- ■ □ □



PART NO. INCLUDES
WB2101- ■ □ □ back stop and end stops



PART NO. INCLUDES
WB2102- ■ □ □ stationary riser shelf with
back stop + full rear panel
workbench end stops



PART NO. INCLUDES
WB2103- ■ □ □ 12" adjustable riser shelf
with back stop
workbench back stop and
end stops

Mobile Workbenches with 1 Mobile Leg and 1 Cabinet

Overall bench height including worksurface is 37 1/4". Includes:

- 1 Lista Mobile Leg (leg is 35 1/2" high)
- 1 stringer
- 1 MP0600-0402FA cabinet



PART NO.
WB2200-



This corporate aircraft operator wanted to upgrade its maintenance facility to match the quality of its aircraft. Several mobile benches, including this mobile inspection station, are used in the company's hangar and support shop.



PART NO. **INCLUDES**
WB2201- back stop and end stops



PART NO. **INCLUDES**
WB2202- stationary riser shelf with
back stop + full rear panel
workbench end stops



The mobile workbench used at this electronic repair facility brings repair tools and parts right to the point of use, without sacrificing durability and drawer storage space. The companion mobile storage cabinet (designed to be stored between the workbench cabinet pedestals) adds to the flexibility of this arrangement. For information on ordering mobile workbenches with two cabinet pedestals, contact your Lista distributor.



PART NO. **INCLUDES**
WB2203- 12" adjustable riser shelf
with back stop
workbench back stop and
end stops

Mobile Workbenches with 1 Mobile Leg and 1 Cabinet

Overall bench height including worksurface is 37 1/4". Includes:

- 1 Lista Mobile Leg (leg is 35 1/2" high)
- 1 stringer
- 1 MP0600-0202FA cabinet



PART NO.
WB2300-

Overall bench height including worksurface is 37 1/4". Includes:

- 1 Lista Mobile Leg (leg is 35 1/2" high)
- 1 stringer
- 1 MP0600-0501FA cabinet

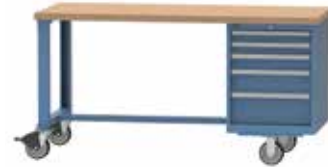

PART NO.
WB2400-



PART NO. INCLUDES
WB2301- back stop and end stops



PART NO. INCLUDES
WB2401- back stop and end stops



PART NO. INCLUDES
WB2302- stationary riser shelf with
back stop + full rear panel
workbench end stops



PART NO. INCLUDES
WB2402- stationary riser shelf with
back stop + full rear panel
workbench end stops



PART NO. INCLUDES
WB2303- 12" adjustable riser shelf
with back stop
workbench back stop and
end stops



PART NO. INCLUDES
WB2403- 12" adjustable riser shelf
with back stop
workbench back stop and
end stops

HOW TO ORDER INDUSTRIAL WORKBENCH CUSTOM CONFIGURATIONS

These are the basic steps required for ordering custom workbenches from Lista.

TO ORDER AN PRECONFIGURED COMBINATION (workbench with preconfigured accessories):

- pages 164-166 for industrial workbenches
- pages 167-169 industrial mobile workbenches

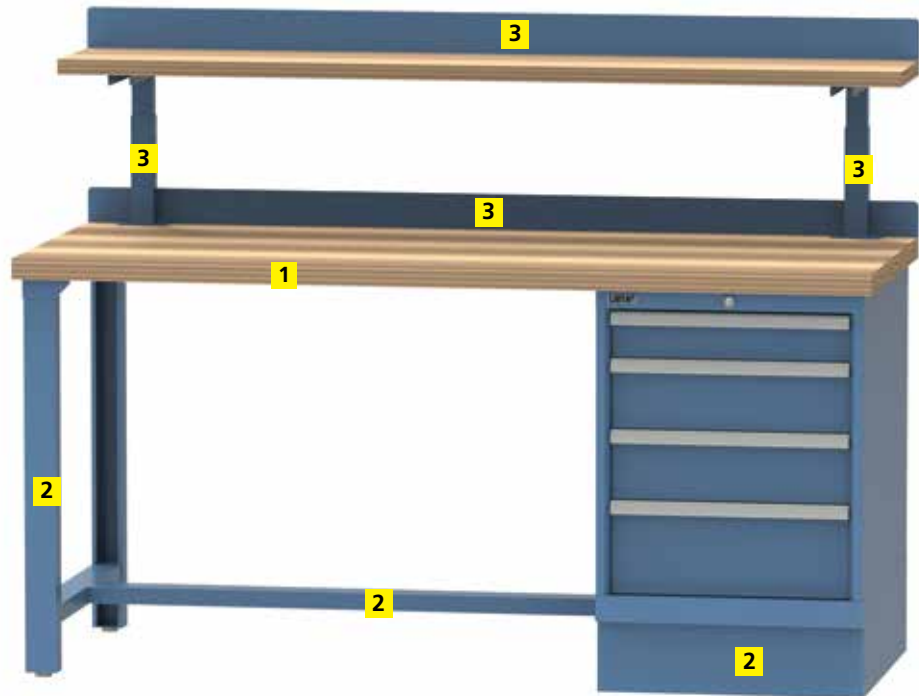

1 Select worksurface
Select the worksurface that best suits your needs from the choices on pages 171-172. Choose the worksurface length, depth and style that you prefer.

2 Select below-worksurface accessories or bases
Select either 2-leg, 1-leg-with-cabinet or 2-cabinet configuration. Legs, stringers, bottom shelves and privacy panels are shown on page 173-174. Hanging cabinets are shown on page 227. To select a cabinet pedestal(s), please see pages 42-51.

3 Select above-worksurface accessories
Select the back stop and end stops (page 175), shelves (stationary or adjustable—see page 176) and/or Nexus System components (pages 236-241) that suit your needs.

4 Select colors
Select a color from the chart on the inside back cover. Cabinet housing and drawer fronts can be different colors, but drawer interiors are always gray.

Sample Workbench Order

QTY.	PART NO.	DESCRIPTION	
1	BTOP-60	butcher block worksurface	1
1	WBLL33.5X28.5	Lista Leg	2
1	WBLST60LLMP	stringer	2
1	MP0600-0402-F6RGG	Easy-Order cabinet pedestals	2
1	WBTBS-60	back stop	3
1	ARS60B	butcher block adjustable riser shelf	3
1	WBTBS-60	shelf back stop	3
	BB	bright blue paint	4

1 INDUSTRIAL WORKBENCH WORKSURFACES

Lista worksurfaces are all easy to maintain, rugged, and durable.

Worksurfaces come in 48", 60", 72", 84", 90" and 96" lengths, and are 24", 30" or 36" deep, depending on worksurface. Other sizes are available, and certain worksurfaces are available with a bullnose front edge.

Butcher Block Worksurface-Sq Edge (BB), Bullnose (BN)

- Satin finish 1 3/4" thick hardwood
- Available in standard square edge or bullnose front edge



Lista Top (LT)

- 1 3/4" thick worksurface with wood core and 3/8" sanded, oil resistant pressed wood, top and bottom



Butcher Block

PART NO. LENGTH

24" deep

BTOP-4824	48"
BTOP-6024	60"
BTOP-7224	72"
BTOP-8424	84"
BTOP-9024	90"
BTOP-9624	96"

30" deep

BTOP-48	48"
BTOP-60	60"
BTOP-72	72"
BTOP-84	84"
BTOP-90	90"
BTOP-96	96"

36" deep

BTOP-4836	48"
BTOP-6036	60"
BTOP-7236	72"
BTOP-8436	84"
BTOP-9036	90"
BTOP-9636	96"

Lista Top (LT)

PART NO. LENGTH

30" deep

LTOP-48	48"
LTOP-60	60"
LTOP-72	72"
LTOP-84*	84"
LTOP-90*	90"
LTOP-96*	96"

36" deep

LTOP-4836	48"
LTOP-6036	60"
LTOP-7236	72"
LTOP-8436*	84"
LTOP-9036*	90"
LTOP-9636*	96"

*requires additional support (third leg or hat section stiffener)

1 INDUSTRIAL WORKBENCH WORKSURFACES

Galvanized Steel Over Wood

Lista Top with additional heavy-gauge galvanized steel cover that is fitted over top and sides of Lista Top, 1 1/16" thick. Gage of steel is 14 gage.



Galvanized Steel Over Wood

PART NO.	LENGTH
----------	--------

30" deep	
LSTOP-48	48"
LSTOP-60	60"
LSTOP-72	72"
LSTOP-84	84"
LSTOP-90	90"
LSTOP-96	96"

36" deep	
LSTOP-4836	48"
LSTOP-6036	60"
LSTOP-7236	72"
LSTOP-8436	84"
LSTOP-9036	90"
LSTOP-9636	96"

Stainless Steel Over Wood

Worksurface is constructed of durable, heavy gauge stainless steel, fitted over top and sides of particle board, 1 1/16" thick. Gage of steel is 18 gage.



Stainless Steel Over Wood

PART NO.	LENGTH
----------	--------

30" deep	
LSSTOP-48	48"
LSSTOP-60	60"
LSSTOP-72	72"
LSSTOP-84	84"
LSSTOP-90	90"
LSSTOP-96	96"

36" deep	
LSSTOP-48X36	48"
LSSTOP-60X36	60"
LSSTOP-72X36	72"
LSSTOP-84X36	84"
LSSTOP-90X36	90"
LSSTOP-96X36	96"

Plastic Laminate

Particle board core with plastic laminated top and sides. 1 1/16" thick. Dove gray is standard but other colors are available on request. Available in standard square edge or bullnose front edge. To order a bullnose edge, add "BN" to the end of the part number.



Plastic Laminate

PART NO.	LENGTH
----------	--------

24" deep	
PTOP-4824	48"
PTOP-6024	60"
PTOP-7224	72"
PTOP-8424*	84"
PTOP-9024*	90"
PTOP-9624*	96"

30" deep	
PTOP-48	48"
PTOP-60	60"
PTOP-72	72"
PTOP-84*	84"
PTOP-90*	90"
PTOP-96*	96"

36" deep	
PTOP-4836	48"
PTOP-6036	60"
PTOP-7236	72"
PTOP-8436*	84"
PTOP-9036*	90"
PTOP-9636*	96"

*requires additional support (third leg or hat section stiffener)

2 BELOW WORKSURFACE LEG HEIGHTS

Use the leg heights shown below to match a cabinet pedestal in a leg-plus-cabinet below-worksurface configuration. For a selection of drawer cabinets to serve as pedestals for workbenches, see pages 42-65.

LEG HEIGHT	MATCHES CAB. PEDESTAL
27 1/2"	600 height without base
29 1/2"	600 height with 2" base
31 1/2"	600 height with 4" base
33 1/2"	600 height with 6" base
	750 height without base
35 1/2" (mobile)	600 height w/mobile base
39 1/2"	900 height without base
	750 height with 6" base



Lista Legs

Each welded one-piece leg assembly is 2 1/2" wide heavy gauge steel. Each foot has a bottom hole for leveling glide (included) or anchoring. Height shown includes leveling glide.

PART NO.	WORKSURFACE DPTH.
27 1/2" (700mm) high	
WBLL27.5X22.5	24" (610mm)
WBLL27.5X28.5	30" (762mm)
WBLL27.5X34.5	36" (915mm)
29 1/2" (750mm) high	
WBLL29.5X22.5	24" (610mm)
WBLL29.5X28.5	30" (762mm)
WBLL29.5X34.5	36" (915mm)
31 1/2" (800mm) high	
WBLL31.5X22.5	24" (610mm)
WBLL31.5X28.5	30" (762mm)
WBLL31.5X34.5	36" (915mm)
33 1/2" (850mm) high	
WBLL33.5X22.5	24" (610mm)
WBLL33.5X28.5	30" (762mm)
WBLL33.5X34.5	36" (915mm)
35 1/2" (900mm) high	
WBLL35.5X22.5	24" (610mm)
WBLL35.5X28.5	30" (762mm)
WBLL35.5X34.5	36" (915mm)
39 1/2" (1000mm) high	
WBLL39.5X22.5	24" (610mm)
WBLL39.5X28.5	30" (762mm)
WBLL39.5X34.5	36" (915mm)

Panel Legs

Same basic construction as the Lista Leg with a formed panel welded in place. Includes leveling glides.

PART NO.	WORKSURFACE DPTH.
27 1/2" (700mm) high	
WBLL/P27.5X22.5	24" (610mm)
WBLL/P27.5X28.5	30" (762mm)
WBLL/P27.5X34.5	36" (915mm)
29 1/2" (750mm) high	
WBLL/P29.5X22.5	24" (610mm)
WBLL/P29.5X28.5	30" (762mm)
WBLL/P29.5X34.5	36" (915mm)
31 1/2" (800mm) high	
WBLL/P31.5X22.5	24" (610mm)
WBLL/P31.5X28.5	30" (762mm)
WBLL/P31.5X34.5	36" (915mm)
33 1/2" (850mm) high	
WBLL/P33.5X22.5	24" (610mm)
WBLL/P33.5X28.5	30" (762mm)
WBLL/P33.5X34.5	36" (915mm)
39 1/2" (1000mm) high	
WBLL/P39.5X22.5	24" (610mm)
WBLL/P39.5X28.5	30" (762mm)
WBLL/P39.5X34.5	36" (915mm)



Lista Mobile Legs

Same basic construction as the Lista Leg but with 2 factory mounted 6" heavy duty casters. Leg is available with either fixed casters or swivel casters with wheel locks. Requires stringer.

Leg with Fixed Casters

PART NO.	WORKSUR. DPTH.
33 1/2" (850mm) overall height	
WBLL/M33.5X22.5R6B	24" (610mm)
WBLL/M33.5X28.5R6B	30" (762mm)
WBLL/M33.5X34.5R6B	36" (915mm)
35 1/2" (900mm) overall height	
WBLL/M35.5X22.5R6B	24" (610mm)
WBLL/M35.5X28.5R6B	30" (762mm)
WBLL/M35.5X34.5R6B	36" (915mm)

Leg with Swivel Casters

PART NO.	WORKSUR. DPTH.
33 1/2" (850mm) overall height	
WBLL/M33.5X22.5S6B	24" (610mm)
WBLL/M33.5X28.5S6B	30" (762mm)
WBLL/M33.5X34.5S6B	36" (915mm)
35 1/2" (900mm) overall height	
WBLL/M35.5X22.5S6B	24" (610mm)
WBLL/M35.5X28.5S6B	30" (762mm)
WBLL/M35.5X34.5S6B	36" (915mm)

Mobile Panel Legs

Same basic construction as the Panel Leg but with 2 factory mounted 6" heavy duty casters. Available with either fixed casters or swivel casters with wheel locks.

Leg with Fixed Casters

PART NO.	WORKSUR. DPTH.
33 1/2" (850mm) overall height	
WBLL/MP33.5X22.5R6B	24" (610mm)
WBLL/MP33.5X28.5R6B	30" (762mm)
WBLL/MP33.5X34.5R6B	36" (915mm)
35 1/2" (900mm) overall height	
WBLL/MP35.5X22.5R6B	24" (610mm)
WBLL/MP35.5X28.5R6B	30" (762mm)
WBLL/MP35.5X34.5R6B	36" (915mm)

Leg with Swivel Casters

PART NO.	WORKSUR. DPTH.
33 1/2" (850mm) overall height	
WBLL/MP33.5X22.5S6B	24" (610mm)
WBLL/MP33.5X28.5S6B	30" (762mm)
WBLL/MP33.5X34.5S6B	36" (915mm)
35 1/2" (900mm) overall height	
WBLL/MP35.5X22.5S6B	24" (610mm)
WBLL/MP35.5X28.5S6B	30" (762mm)
WBLL/MP35.5X34.5S6B	36" (915mm)







2 INDUSTRIAL WORKBENCH BELOW-WORKSURFACE ACCESSORIES

Stringers/Foot Rests



Telescoping heavy gauge U channel with 2 mounting holes on each end plate.



Stringers/Foot Rests

PART NO.	WORKSURF. LENGTH
WBLST48/ 	48"
WBLST60/ 	60"
WBLST72/ 	72"
WBLST84/ 	84"
WBLST90/ 	90"
WBLST96/ 	96"

How to order stringers and bottom shelves

1. Select **part number** based on workbench length.
2.  Specify **left-hand** (facing the workbench) bench support.
 - LL** = Lista Leg or Panel Leg
 - NW** = NW cabinet
 - MP** = MP cabinet
3.  Specify **right-hand** (facing the workbench) bench support.
 - LL** = Lista Leg or Panel Leg
 - NW** = NW cabinet
 - MP** = MP cabinet

4. Choose color





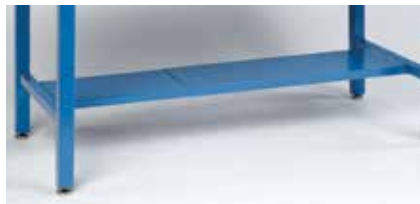

EXAMPLE: to order a bottom shelf for a workbench with a 72" worksurface, an MP Width cabinet as the left-hand pedestal and a Lista Leg as the right-hand support, the part number would be **WBLBS72/MPLL**.

Bottom Shelves

Telescoping heavy gauge steel shelf, 12" deep, for use as storage or foot rest. 150 lb. weight capacity for evenly distributed loads, except as noted.



Bottom Shelves

PART NO.	WORKSURF. LENGTH
WBLBS48/ 	48"
WBLBS60/ 	60"
WBLBS72/ 	72"
WBLBS84/ 	84"
WBLBS90/ 	90"
WBLBS96/ 	96"

*100 lb. weight capacity

Privacy Panels

Steel panel attaches to leg or cabinet and runs full length of worksurface. 22 3/4" high. Panels are mounted behind the legs and add 3/4" to the leg depth.



Privacy Panels

PART NO.	WORKSURF. LENGTH
WBLPP22.8X48	48"
WBLPP22.8X60	60"
WBLPP22.8X72	72"
WBLPP22.8X84	84"
WBLPP22.8X90	90"
WBLPP22.8X96	96"

3 INDUSTRIAL WORKBENCH ABOVE-WORKSURFACE ACCESSORIES

The bench components on this page allow you to customize above the worksurface for your particular needs.

All parts must be ordered separately to match the length of the worksurface you have chosen.

Back Stops and End Stops

Steel back stops and end stops have rounded corners. End stops are 2" shorter than work surface depth. For use with worksurfaces or shelves.

Adjustable Riser Shelf Assemblies

Shelves measure 1 1/4" thick x 12" deep. Shelf height can be adjusted in 1 1/2" increments from 12"-18". A steel back stop is available for the shelf assembly (ordered separately – see above). Includes the number of adjustable support brackets shown in the charts.

Adjustable Support Bracket

Bracket supports riser shelf. May be required to supplement the supports included with shelf assemblies (see charts above) for support of long shelves or shelves carrying heavy loads.

PART NO.
ARS-BR

How to order workbench above-worksurface accessories

1. Select worksurface length and depth.
2. Select back stop, end stop, shelf or panel part numbers to correspond to both length and depth of worksurface.
3. Specify paint color from the chart on the inside back cover.



Back Stops

PART NO.	WORKSURFACE LENGTH
WBTBS-48	48"
WBTBS-60	60"
WBTBS-72	72"
WBTBS-84	84"
WBTBS-90	90"
WBTBS-96	96"

End Stops (pair)

PART NO.	WORKSURFACE DEPTH
WBTES-22	24"
WBTES-28	30"
WBTES-34	36"

Assemblies with Plastic Laminate Shelf

PART NO.	WKSURF. LGTH.	# SUPPORTS
ARS48P	48"	2
ARS60P	60"	2
ARS72P	72"	2
ARS84P	84"	3
ARS90P	90"	3
ARS96P	96"	3

Assemblies w/Butcher Block Shelf

PART NO.	WKSURF. LGTH.	# SUPPORTS
ARS48B	48"	2
ARS60B	60"	2
ARS72B	72"	2
ARS84B	84"	2
ARS90B	90"	3
ARS96B	96"	3

3 INDUSTRIAL WORKBENCH ABOVE-WORKSURFACE ACCESSORIES

Stationary Riser Shelves – 10 ½" deep

Made of steel to support heavy loads. Shelf is 13 ½" overall height (12" clearance). Optional louvered closed back rear panel is shown above.

Stationary Riser Shelves – 15" deep

Provides additional storage depth. Particularly suited for supporting overhead cabinets. Shelf is 13 ½" overall height (12" clearance). Optional pegboard closed back rear panel is shown. Shelf is 13 ½" high overall (12" clearance). Other heights available. Specify paint color(s) from chart on inside back cover.



Stationary Riser Shelves – 10 ½" deep

Open Riser Shelves

Open shelf (open back, no shelf back stop)

PART NO.	WORKSURFACE LENGTH
SRS48	48"
SRS60	60"
SRS72	72"
SRS84	84"
SRS90	90"
SRS96	96"

Open Riser Shelves with Shelf Back Stop

Shelf with back stop (open back)

PART NO.	WORKSURFACE LENGTH
SRS48-1	48"
SRS60-1	60"
SRS72-1	72"
SRS84-1	84"
SRS90-1	90"
SRS96-1	96"

Riser Shelves with Full Panel

Solid closed back, with shelf back stop

PART NO.	WORKSURFACE LENGTH
SRS48-2	48"
SRS60-2	60"
SRS72-2	72"
SRS84-2	84"
SRS90-2	90"
SRS96-2	96"

Riser Shelves with Perforated Full Panel

Pegboard closed back, with shelf back stop

PART NO.	WORKSURFACE LENGTH
SRS48-2P	48"
SRS60-2P	60"
SRS72-2P	72"
SRS84-2P	84"
SRS90-2P	90"
SRS96-2P	96"

Riser Shelves with Louvered Full Panel

Louvered closed back, with shelf back stop (shown above)

PART NO.	WORKSURFACE LENGTH
SRS48-2L	48"
SRS60-2L	60"
SRS72-2L	72"
SRS84-2L	84"
SRS90-2L	90"
SRS96-2L	96"



Stationary Riser Shelves – 15" deep

Open Riser Shelves

Open back, no shelf backstop

PART NO.	TOP LENGTH
SRS48-15D	48"
SRS60-15D	60"
SRS72-15D	72"
SRS84-15D	84"
SRS96-15D	96"

Open Riser Shelves with Shelf Back Stop

Open back, with shelf backstop

PART NO.	TOP LENGTH
SRS48-1-15D	48"
SRS60-1-15D	60"
SRS72-1-15D	72"
SRS84-1-15D	84"
SRS96-1-15D	96"

Riser Shelves with Full Panel

Solid closed back, with shelf backstop

PART NO.	TOP LENGTH
SRS48-2-15D	48"
SRS60-2-15D	60"
SRS72-2-15D	72"
SRS84-2-15D	84"
SRS96-2-15D	96"

Riser Shelves with Perforated Full Panel

Pegboard closed back, with shelf backstop

PART NO.	TOP LENGTH
SRS48-2P-15D	48"
SRS60-2P-15D	60"
SRS72-2P-15D	72"
SRS84-2P-15D	84"
SRS96-2P-15D	96"

Riser Shelves with Louvered Full Panel

Louvered closed back, with shelf backstop

PART NO.	TOP LENGTH
SRS48-2L-15D	48"
SRS60-2L-15D	60"
SRS72-2L-15D	72"
SRS84-2L-15D	84"
SRS96-2L-15D	96"

TECHNICAL ELECTRONIC WORKSTATIONS

Featuring a sleek, aesthetically pleasing design, the real beauty of Lista's technical electronic workstations is their ability to perfectly suit the widest variety of applications.

Our modular approach is the key to our technical electronic workstation's versatility, with flexible standard components and accessory options both above and below the worksurface, leading to greater productivity and efficiency.

Many configurations feature a built-in electrical power supply, conveniently located on either an instrument riser or as a part of the Nexus accessory system (for more on the Nexus system, see pages 236-241).

Choose from a wide array of static-safe components, including ESD paint, worksurfaces and shelves, conductive plastic boxes and grounding accessories.

Technical electronic workstations have a 1,000 lb. (454kg) weight capacity, and can be configured with a variety of leg and cabinet pedestal choices, including mobile bases for increased flexibility and ease of reconfiguration. Mobile workstations can be quickly moved to and from a work site.



- Wide choice of above-worksurface accessories
- Access to electrical power available on instrument risers and Nexus Accessory System
- Durable worksurfaces come in multiple lengths and depths, in a choice of materials, including ESD
- Front and rear top support rails protect integrity of worksurface
- Choice of pedestal and leg supports, including Tech Leg, Tech Panel Leg and a large selection of cabinet pedestals
- Choice of leveling glides or mobile casters (for 4-leg configurations)

TECHNICAL ELECTRONIC WORKSTATIONS

Easy-Order technical electronic workstations include Narrow Width (16 7/8" wide) cabinet pedestals (see pages 42–51 for descriptions).

How to order an Preconfigured Technical Electronic Workstation

1. Select Preconfigured workstation.

2. Select worksurface style. See pages 171–172 for descriptions.

- PLB** = Plastic laminate
- BTB** = Butcher block
- SDB** = Static dissipative (includes ground cord and hardware)

All worksurfaces have a bullnose front edge and are 30" deep.

3. Select worksurface size.

- 4830** = 48" long x 30" deep
- 6030** = 60" long x 30" deep
- 7230** = 72" long x 30" deep

4. Select paint color. For color chart, see inside back cover.

EXAMPLE: to order a TB3201 workstation with a 72" long plastic laminate worksurface and shelf and Bright Blue paint, the part number would be **TB3201-PLB7230BB**.

5. Select cabinet pedestals (for TB03xx and TB06xx configurations). For Preconfigured cabinet pedestals, see pages 42–51 for Narrow Width cabinets and MP Width Cabinets.

EXAMPLE (CUSTOMER-SPECIFIED CABINETS): to order a TB0300 workstation with a 72" long plastic laminate worksurface, and an NW0750-0601NA cabinet pedestal with Bright Blue paint, the workstation part number would be **TB0300-PLB7230BB**, and the cabinet part number would be **NW0750-0601NA-NBRGGB**.

Workstations with 2 Tech Legs

Overall bench height including work surface is 35 1/4". Includes:

- 2 tech panel legs (legs 33 1/2" high)
- 1 pair of top support rails
- 1 stringer



PART NO.
TB3000-



PART NO. INCLUDES
TB3001- 12" adj. riser shelf w/back stop workstation back stop



PART NO. INCLUDES
TB3002- (2) 16" instrument riser supports (1 with power) 12" deep instru. riser shelf worksta. + shelf back stops



PART NO. INCLUDES
TB3003- 15" deep station. riser shelf with louvered back panel (2) 16" high overhead cabs with retractable doors*

*48" long benches include (1) overhead cabinet

Workstations with 2 Tech Legs and 1 Drawer

Overall bench height including work surface is 35 1/4". Includes:

- 2 tech panel legs (legs 33 1/2" high)
- 1 pair of top support rails
- 1 stringer
- 1 WBHC150-1 hanging cabinet



PART NO.
TB3100-



PART NO. INCLUDES
TB3101- 12" adj. riser shelf w/back stop workstation back stop



PART NO. INCLUDES
TB3102- (2) 16" instrument riser supports (1 with power) 12" deep instru. riser shelf worksta. + shelf back stops



PART NO. INCLUDES
TB3103- 15" deep station. riser shelf with louvered back panel (2) 16" high overhead cabs with retractable doors*

*48" long benches include (1) overhead cabinet

Workstations with 1 Tech Leg and 1 Cabinet

Overall bench height including work surface is 35 1/4". Includes:

- 1 tech panel leg (leg 33 1/2" high)
- 1 pair of top support rails
- 1 stringer
- 1 NW0600-0402NA-F6RG cabinet



PART NO.
TB3200-■■□



PART NO. **INCLUDES**
TB3201-■■□ 12" adj. riser shelf w/back stop
workstation back stop



PART NO. **INCLUDES**
TB3202-■■□ (2) 16" instrument riser
supports (1 with power)
12" deep instru. riser shelf
worksta. + shelf back stops



PART NO. **INCLUDES**
TB3203-■■□ 15" deep station. riser shelf
with louvered back panel
(2) 16" high overhead cabs
with retractable doors*

*48" long benches include (1) overhead cabinet

Workstations with 1 Leg, 1 Customer-Specified Cab.

Overall bench height including work surface is 35 1/4". Includes:

- 1 tech panel leg (leg 33 1/2" high)
- 1 pair of top support rails
- 1 stringer
- cabinet pedestal chosen by customer



PART NO.
TB0300-■■□



PART NO. **INCLUDES**
TB0301-■■□ 12" adj. riser shelf w/back stop
workstation back stop



PART NO. **INCLUDES**
TB0302-■■□ (2) 16" instrument riser
supports (1 with power)
12" deep instru. riser shelf
worksta. + shelf back stops



PART NO. **INCLUDES**
TB0303-■■□ 15" deep station. riser shelf
with louvered back panel
(2) 16" high overhead cabs
with retractable doors*

*48" long benches include (1) overhead cabinet

Workstations with 2 Cabinets

Overall bench height including work surface is 35 1/4". Includes:

- 1 NW0600-0402NA-F6KA cabinet*
- 1 NW0600-0202NA-F6KA cabinet*

*includes keyed-alike locks



PART NO.
TB3400- ■ ■

Overall bench height including work surface is 35 1/4". Includes:

- 1 NW0600-0501NA-F6KA cabinet*
- 1 NW0600-0201N-F6KA cabinet*

*includes keyed-alike locks



PART NO.
TB3500- ■ ■

Workstations with 2 Customer-Specified Cabinets

Overall bench height including work surface is 35 1/4". Includes:

- 2 cabinet pedestals chosen by customer



PART NO.
TB0600- ■ ■



PART NO. **INCLUDES**
TB3401- ■ ■ 12" adj. riser shelf w/back stop
workstation back stop



PART NO. **INCLUDES**
TB3501- ■ ■ 12" adj. riser shelf w/back stop
workstation back stop



PART NO. **INCLUDES**
TB0601- ■ ■ 12" adj. riser shelf w/back stop
workstation back stop



PART NO. **INCLUDES**
TB3402- ■ ■ (2) 16" instrument riser
supports (1 with power)
12" deep instru. riser shelf
worksta. + shelf back stops



PART NO. **INCLUDES**
TB3502- ■ ■ (2) 16" instrument riser
supports (1 with power)
12" deep instru. riser shelf
worksta. + shelf back stops



PART NO. **INCLUDES**
TB0602- ■ ■ (2) 16" instrument riser
supports (1 with power)
12" deep instru. riser shelf
worksta. + shelf back stops



PART NO. **INCLUDES**
TB3403- ■ ■ 15" deep station. riser shelf
with louvered back panel
(2) 16" high overhead cabs
with retractable doors*

*48" long benches include (1) overhead cabinet



PART NO. **INCLUDES**
TB3503- ■ ■ 15" deep station. riser shelf
with louvered back panel
(2) 16" high overhead cabs
with retractable doors*

*48" long benches include (1) overhead cabinet



PART NO. **INCLUDES**
TB0603- ■ ■ 15" deep station. riser shelf
with louvered back panel
(2) 16" high overhead cabs
with retractable doors*

*48" long benches include (1) overhead cabinet

HOW TO ORDER TECHNICAL ELECTRONIC WORKSTATION CUSTOM CONFIGURATIONS

These are the basic steps required for ordering custom technical electronic workstations.

TO ORDER AN PRECONFIGURED COMBINATION (workstation with preconfigured accessories), see pages 40–41.

- 1 Select workspace**
Select the workspace that best suits your needs from the choices on pages 171–172. Choose the workspace length, depth and style that you prefer.
- 2 Select below-worksurface accessories or bases**
Select either 2-leg, 1-leg-with-cabinet or 2-cabinet configuration. Legs, stringers, bottom shelves and privacy panels are shown on page 173-174. Hanging cabinets are shown on page 227. To select a cabinet pedestal(s), please see pages 42–51.
- 3 Select above-worksurface accessories**
Select the back stop and end stops (page 175), shelves (instrument riser or adjustable – see page 176) and/or Nexus System components (pages 234–241) that suit your needs.
- 4 Select colors**
Select a color from the chart on the inside back cover. Cabinet housing and drawer fronts can be different colors, but drawer interiors are always gray.

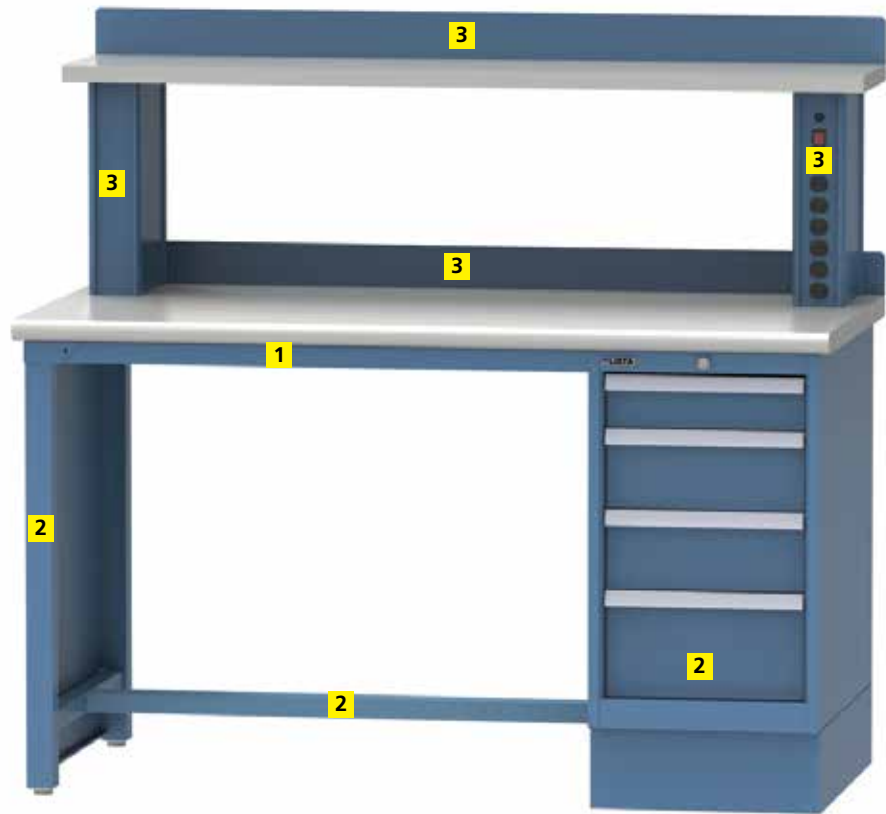

Sample Workstation Order

QTY.	PART NO.	DESCRIPTION
1	PTOP-60BN	plastic laminate worksurface with bullnose edge 60" x 30" 1
1	WBTL33.5X28.5	Tech Leg 2
1	WBLST60TLNW	stringer 2
1	WBTSC60TLNW	top support rails (pair) 2
1	NW0600-0402N-F6RGGBB	Easy-Order cabinet pedestal 2
1	WBTBS-60	workstation back stop 3
1	IRSS20	instrument riser support 3
1	IRSS20/15	instrument riser support 3
1	PS6012	plastic laminate riser shelf 3
1	WBTBS-60	shelf back stop 3
	BB	bright blue paint 4

1 TECHNICAL ELECTRONIC WORKSURFACES

Lista worksurfaces are all easy to maintain, rugged, and durable.

Worksurfaces come in 48", 60", 72", 84", 90" and 96" lengths, and are 24", 30" or 36" deep, depending on worksurface. Other sizes are available, and certain worksurfaces are available with a bullnose front edge.

Plastic Laminate

Particle board core with plastic laminated top and sides. 1 9/16" thick. Dove gray is standard but other colors are available on request. Available in standard square edge or bullnose front edge (shown above). To order a bullnose edge, add "BN" to the end of the part number.

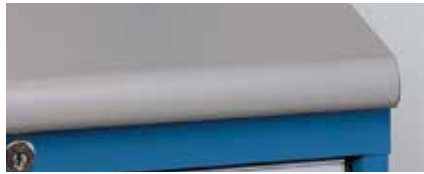

Static Dissipative Plastic Laminate

Particle board core with plastic laminated top and sides, 1 9/16" thick. Grounding bolt and 10' grounding cord with a 1 megohm resistor included (installation required). Standard color is dove gray but other colors available on request. Available in standard square edge or bullnose front edge (shown above). To order a bullnose edge, add "BN" to end of part number.

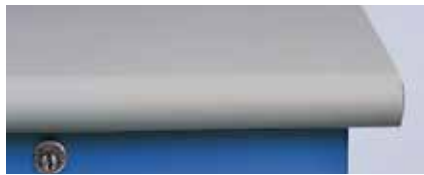

Worksurfaces display electrical properties within static dissipative boundaries of 10⁶-10⁹ ohms over a wide range of relative humidities (ranging from 60% RH to as low as 10% RH) to meet ESD specifications. Meets EOS/ESD S4.1 specifications. For detailed specifications, please contact Lista.

Static Dissipative Worksurface

Accessories ESD Isolation Kits

Required to prevent a redundant ground (ground loop) with cabinet/ worksurface grounding system. Necessary when powered items are used with either non-ESD painted Nexus accessories, ESD painted Nexus accessories with static dissipative worksurfaces, or powered instrument riser shelves on static dissipative worksurfaces.

PART NO.	DESCRIPTION
ESDISO-KIT/RSS	instrument riser shelf isolation kit

Grounding Kits

Kit is supplied with all static dissipative worksurfaces and shelves. See page 187 for shelves. If additional kits are needed use corresponding part numbers below.

PART NO.	DESCRIPTION
GCT	worksurface kit 8' cord w/1 megohm resistor
GCS	shelf kit, 6' cord w/out 1 megohm resistor

Plastic Laminate

PART NO.	LENGTH
24" deep	
PTOP-4824	48"
PTOP-6024	60"
PTOP-7224	72"
PTOP-8424*	84"
PTOP-9024*	90"
PTOP-9624*	96"

30" deep

PTOP-48	48"
PTOP-60	60"
PTOP-72	72"
PTOP-84*	84"
PTOP-90*	90"
PTOP-96*	96"

36" deep

PTOP-4836	48"
PTOP-6036	60"
PTOP-7236	72"
PTOP-8436*	84"
PTOP-9036*	90"
PTOP-9636*	96"

*requires additional support (third leg or hat section stiffener)

Static Dissipative

Plastic Laminate

PART NO.	LENGTH
24" deep	
SDTOP-4824	48"
SDTOP-6024	60"
SDTOP-7224	72"
SDTOP-8424*	84"
SDTOP-9024*	90"
SDTOP-9624*	96"

30" deep

SDTOP-48	48"
SDTOP-60	60"
SDTOP-72	72"
SDTOP-84*	84"
SDTOP-90*	90"
SDTOP-96*	96"

36" deep

SDTOP-4836	48"
SDTOP-6036	60"
SDTOP-7236	72"
SDTOP-8436*	84"
SDTOP-9036*	90"
SDTOP-9636*	96"

*requires additional support (third leg or hat section stiffener)

1 TECHNICAL ELECTRONIC WORKSURFACES (CONT)

Phenolic Resin

A high-pressure laminate designed for laboratory worksurfaces. Resistant to chemicals, stains or discoloration. Worksurface is 1" thick phenolic resin, available in black.



Phenolic Resin

PART NO.	SIZE
RTOP-48	48" long x 30" deep
RTOP-60	60" long x 30" deep
RTOP-72*	72" long x 30" deep
RTOP-84*	84" long x 30" deep
RTOP-90*	90" long x 30" deep
RTOP-96*	96" long x 30" deep

*requires additional support (third leg or hat section stiffener)

Butcher Block

Satin finish 1 3/4" thick hardwood. Available in standard square edge or bullnose front edge (shown above). To order a bullnose edge, add "BN" to the end of the part number.



PART NO.	LENGTH	PART NO.	LENGTH	PART NO.	LENGTH
24" deep		30" deep		36" deep	
BTOP-4824	48"	BTOP-48	48"	BTOP-4836	48"
BTOP-6024	60"	BTOP-60	60"	BTOP-6036	60"
BTOP-7224	72"	BTOP-72	72"	BTOP-7236	72"
BTOP-8424	84"	BTOP-84	84"	BTOP-8436	84"
BTOP-9024	90"	BTOP-90	90"	BTOP-9036	90"
BTOP-9624	96"	BTOP-96	96"	BTOP-9636	96"

Ball Transfer Worksurfaces

Ball transfer worksurfaces offer a cost effective, efficient means of workflow management for products or pallets in an assembly, repair or rework environment. Please contact your Lista representative for help in configuring a system and providing the solution best suited to your requirements.



2 TECHNICAL ELECTRONIC WORKSTATION BELOW-WORKSURFACE COMPONENTS

Tech Legs

2" x 2" tube leg pair with cross piece. Legs include glides for leveling on uneven surfaces. Top support rails are required for all workstation configurations which include Tech Leg(s) (not included).

Tech Panel Legs

Same basic construction as the Tech Leg with a formed panel welded in place. Includes leveling glides. Top support rails are required for all workstation configurations which include Tech Panel Leg(s) (not included).



Tech Leg



Tech Panel Leg

Tech Leg Mobile Casters (Swivel)

Pair of swivel stem casters used to add mobility to Tech Legs and Tech Panel Legs. Wheels are 5" x 1 1/4" and replace glides which come with stationary legs. Tech Legs with mobile casters can not be paired with a cabinet pedestal. Caster height is 6".



Tech Leg Mobile Casters

Tech Leg Extenders

Pair of extenders is used to add additional height adjustment for stationary Tech Legs and Tech Panel Legs. Adds up to 6" in height in 1" increments. Extender accepts glides for leveling and/or additional height adjustment.



Tech Leg Extenders

Top Support Rails

Pair of rails support front and back of work-surface to protect integrity of top. Required for all technical electronic workstations with at least one leg. Not for use with workstations with 2 cabinet pedestals. Comes as pair.



Top Support Rails

Tech Legs

PART NO.	WORKSURFACE DEPTH
27 1/2" (700mm) high	
WBTL27.5X22.5	24" (610mm)
WBTL27.5X28.5	30" (762mm)
WBTL27.5X34.5	36" (915mm)

33 1/2" (850mm) high

WBTL33.5X22.5	24" (610mm)
WBTL33.5X28.5	30" (762mm)
WBTL33.5X34.5	36" (915mm)

Tech Panel Legs

PART NO.	WORKSURFACE DEPTH
27 1/2" (700mm) high	
WBTL/P27.5X22.5	24" (610mm)
WBTL/P27.5X28.5	30" (762mm)
WBTL/P27.5X34.5	36" (915mm)

33 1/2" (850mm) high

WBTL/P33.5X22.5	24" (610mm)
WBTL/P33.5X28.5	30" (762mm)
WBTL/P33.5X34.5	36" (915mm)

Tech Leg Mobile Casters

PART NO.	DESCRIPTION
WBTL/C.AST5WB	pair, with wheel brake
WBTL/C.AST5NB	pair, w/o wheel brake

Tech Leg Extenders

PART NO.	DESCRIPTION
WBTL/EXT6	pair

Top Support Rails

PART NO.	WORKSURF. LENGTH
WBTSC48/	48"
WBTSC60/	60"
WBTSC72/	72"
WBTSC84/	84"

How to order top support rails

- Select part number based on worksurface length.
- Specify left-hand (facing the workstation) bench support.
 - TL = Tech Leg or Panel Leg
 - NW* = NW cabinet
 - MP* = MP cabinet
- Specify right-hand (facing the workstation) bench support.
 - TL = Tech Leg or Panel Leg
 - NW* = NW cabinet
 - MP* = MP cabinet

EXAMPLE: to order a pair of top support rails for a workstation with a 72" worksurface, an MP Width cabinet as the left-hand pedestal and a Tech Leg as the right-hand support, the part number would be **WBTSC72/MP TL**.

**top support rail not used to support worksurface of workstations with 2 cabinet pedestals*

2 TECHNICAL ELECTRONIC WORKSTATION BELOW-WORKSURFACE COMPONENTS (CONT)

Stringers/Foot Rests

Telescoping heavy gauge U channel with 2 mounting holes on each end plate.

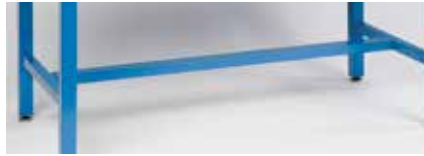

Bottom Shelves

Telescoping heavy gauge steel shelf, 12" deep, for use as storage or foot rest. 150 lb. weight capacity for evenly distributed loads, except as noted.

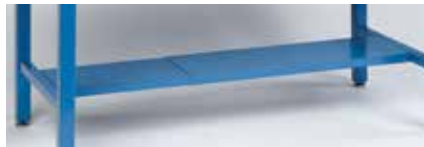

How to order stringers and bottom shelves

1. **Select part number** based on worksurface length.
2. **Specify left-hand** (facing the workstation) **bench support.**
TL = Tech Leg or Panel Leg
NW = NW cabinet
MP = MP cabinet
3. **Specify right-hand** (facing the workstation) **bench support.**
TL = Tech Leg or Panel Leg
NW = NW cabinet
MP = MP cabinet

EXAMPLE: to order a bottom shelf for a workstation with a 72" worksurface, an MP Width cabinet as the left-hand pedestal and a Tech Leg as the right-hand support, the part number would be **WBLBS72/MPTL**.

Cabinet Pedestals

For a selection of drawer cabinets to serve as pedestals for technical electronic workstations, see pages 42–65.



Privacy Panels

Steel panel attaches to leg or cabinet and runs full length of worksurface. 22 3/4" high.

Wrist Strap and Ground Block

Mounts to underside of worksurface. Dual receptacles for 2 wrist straps.



Ground Kits

Kit is supplied with all static dissipative worksurfaces or shelves. Includes attaching hardware.

Stringers/Foot Rests

PART NO.	WORKSURF. LENGTH
WBLST48/	48"
WBLST60/	60"
WBLST72/	72"
WBLST84/	84"
WBLST90/	90"
WBLST96/	96"

Bottom Shelves

PART NO.	WORKSURF. LENGTH
WBLBS48/	48"
WBLBS60/	60"
WBLBS72/	72"
WBLBS84/	84"
WBLBS90/	90"
WBLBS96/	96"

*100 lb. weight capacity

Privacy Panels

PART NO.	WORKSURF. LENGTH
WBLPP22.8X48	48"
WBLPP22.8X60	60"
WBLPP22.8X72	72"
WBLPP22.8X84	84"
WBLPP22.8X90	90"
WBLPP22.8X96	96"

Wrist Strap and Ground Block

PART NO.	DESCRIPTION
GB	ground block
WS	wrist strap with 6' coil cord*

* with 1 megohm resistor

Ground Kits

PART NO.	DESCRIPTION
GCT	worksurface kit with 8' cord*
GCS	shelf kit with 6' cord**

* with 1 megohm resistor

** without 1 megohm resistor

3 TECHNICAL WORKBENCH ABOVE-WORKSURFACE ACCESSORIES

The bench components on this page allow you to customize above the worksurface for your particular needs.

All parts must be ordered separately to match the length of the worksurface you have chosen.

Back Stops and End Stops

Steel back stops and end stops have rounded corners. End stops are 2" shorter than work surface depth. For use with worksurfaces or shelves.



Back Stops

PART NO.	WORKSURFACE LENGTH
WBTBS-48	48"
WBTBS-60	60"
WBTBS-72	72"
WBTBS-84	84"
WBTBS-90	90"
WBTBS-96	96"

End Stops (pair)

PART NO.	WORKSURFACE DEPTH
WBTES-22	24"
WBTES-28	30"
WBTES-34	36"

Adjustable Riser Shelf Assemblies

Shelves measure 1 1/4" thick x 12" deep. Shelf height can be adjusted in 1 1/2" increments from 12"-18". A steel back stop is available for the shelf assembly (ordered separately – see above). Includes the number of adjustable support brackets shown in the charts.



Adjustable Support Bracket

Bracket supports riser shelf. May be required to supplement the supports included with shelf assemblies (see charts to the right) for support of long shelves or shelves carrying heavy loads.

PART NO.
ARS-BR

Adjustable Riser Shelf Assemblies

WKSURFACE LENGTH	PLASTIC LAMINATE PART NO.	PLASTIC LAM. # SUPPORTS	BUTCHER BLOCK PART NO.	BUTER BL. # SUPPORTS
48"	ARS48P	2	ARS48B	2
60"	ARS60P	2	ARS60B	2
72"	ARS72P	2	ARS72B	2
84"	ARS84P	3	ARS84B	2
90"	ARS90P	3	ARS90B	3
96"	ARS96P	3	ARS96B	3

For additional support individual brackets can be purchased separately by ordering part no. ARS-BR

How to order workbench above-worksurface accessories

1. Select worksurface length and depth.
2. Select back stop, end stop, shelf or panel part numbers to correspond to both length and depth of worksurface.
3. Specify paint color from the chart on the inside back cover.

3 TECHNICAL WORKBENCH ABOVE-WORKSURFACE ACCESSORIES (CONT)

Riser Shelves

All shelves measure 1 1/4" thick x 12" or 15" deep and mount to shelf supports. Add "12" or "15" in place of the green box (■) in the part number to specify a shelf depth of 12" or 15". Back stops for shelves can be ordered from the chart on the previous page.



Static Dissipative Plastic Laminate Shelves

Comes with grounding bolt and grounding cord. See chart on the right for static dissipative specifications.



Instrument Riser Shelf Rear Panels

Full rear panel extends from worksurface to form back panel between the worksurface and riser shelf. Available flush with the shelf or with a 2" back stop for the riser shelf.

Instrument Riser Shelf Rear Panels

PART NO.	DESCRIPTION
Flush with shelf	
IRS-FRP ■ ■	solid rear panel
IRS-FRP ■ ■ -P	pegboard rear panel
IRS-FRP ■ ■ -L	louvered rear panel
With 2" back stop	
IRS-FRP ■ ■ -2	solid rear panel
IRS-FRP ■ ■ -2P	pegboard rear panel
IRS-FRP ■ ■ -2L	louvered rear panel

Instrument Riser Shelf Supports

Either 16", 20" or 24" high, with removable side panels. 20" and 24" models provide extra space to run air lines or meet additional power requirements. Ordered individually. Shelves ordered separately (see right). See page 185 for isolation kits when used with static dissipative worksurfaces.'



How to order a rear panel

1. Select part number.

2. ■ Specify shelf length.

- 48 = 48" long
- 60 = 60" long
- 72 = 72" long
- 84 = 84" long
- 90 = 90" long
- 96 = 96" long

3. ■ Specify shelf support height.

- 16 = 16" high
- 20 = 20" high
- 24 = 24" high

EXAMPLE: to order a pegboard rear panel for a 60" long shelf with 16" shelf supports, the part number is **IRS-FRP6016-P**.

Riser Shelves

Plastic Laminate Shelves

PART NO.	LENGTH
PS48 ■ ■	48"
PS60 ■ ■	60"
PS72 ■ ■ *	72"
PS84 ■ ■ **	84"
PS90 ■ ■ **	90"
PS96 ■ ■ **	96"

*Lista recommends using a back stop or third center support with 72" shelves

**Lista recommends using a third center support with 84", 90" and 96" shelves

Static Dissipative Plastic Laminate Shelves

PART NO.	LENGTH
SD48 ■ ■	48"
SD60 ■ ■	60"
SD72 ■ ■ *	72"
SD84 ■ ■ **	84"
SD90 ■ ■ **	90"
SD96 ■ ■ **	96"

*Lista recommends using a back stop or third center support with 72" shelves

**Lista recommends using a third center support with 84", 90" and 96" shelves

Butcher Block Shelves

PART NO.	LENGTH
BS48 ■ ■	48"
BS60 ■ ■	60"
BS72 ■ ■	72"
BS84 ■ ■ *	84"
BS90 ■ ■ *	90"
BS96 ■ ■ *	96"

*Lista recommends using a third center support with 84", 90" and 96" shelves

Instrument Riser Shelf Supports

16" High Supports

PART NO.	DESCRIPTION
IRSS16	No power
IRSS16/15	with 15 amp
IRSS16/20	with 20 amp
IRSS16/GF-15	with 15 amp GFCI
IRSS16/GF-20	with 20 amp GFCI

20" High Supports

PART NO.	DESCRIPTION
IRSS20	No power
IRSS20/15	with 15 amp
IRSS20/20	with 20 amp
IRSS20/GF-15	with 15 amp GFCI
IRSS20/GF-20	with 20 amp GFCI

24" High Supports

PART NO.	DESCRIPTION
IRSS24	No power
IRSS24/15	with 15 amp
IRSS24/20	with 20 amp
IRSS24/GF-15	with 15 amp GFCI
IRSS24/GF-20	with 20 amp GFCI

ARLINK 7000® WORKBENCHES

All-Purpose Arlink® 7000 workbenches are available in twelve standard sizes and two heights. Simply choose the base size, height and worksurface that best suits your needs, and add appropriate accessories. For other options and dimensions, please contact your Lista representative.

All-Purpose Arlink® 7000 Workbench

- Workbench height is 30" (76 cm) or 36" (91 cm)
- Heavy-duty 2" x 2" tubular legs include leveling glides
- Load capacity for bench is 1,000 lbs. (454 kg) evenly distributed



Paint Colors

Paint and trim colors for the Arlink 8000 Modular Workstation, Arlink VSI-8 upright system and the Arlink 7000 All Purpose Workbench have been expanded to include new and additional options.

Standard paint colors for both lines will continue to be Light Gray and Sand. Bright Blue and Black are being added as no upcharge options and will be available with standard lead times based on production volume at the time of order.



Light Gray (LG)



Sand (SN)



Bright Blue (BB)



Black (BL)

Worksurface Material Legend

- SL = Standard Laminate
- SD = Static Dissipative Laminate
- BB = Butcher Block-Sq Edge
- BN = Butcher Block - Bullnose Edge
- SS = Stainless Steel Over Wood Core
- RT = Phenolic Resin
- LT = Lista Top
- ST = Galvanized Steel Over Wood Core

ARLINK 7000 WORKBENCH COMBINATIONS

Stationary Workbench without Optional Leg Extenders

Bench Depth 30", Bench Height 30"

	SL	SD	BB	BN	SS	RT	LT	ST
36X30X30H	363030SL	363030SD	363030BB	363030BN	363030SS	363030RT	363030LT	363030ST
48X30X30H	483030SL	483030SD	483030BB	483030BN	483030SS	483030RT	483030LT	483030ST
60X30X30H	603030SL	603030SD	603030BB	603030BN	603030SS	603030RT	603030LT	603030ST
72X30X30H	723030SL	723030SD	723030BB	723030BN	723030SS	723030RT	723030LT	723030ST
84X30X30H	843030SL	843030SD	843030BB	843030BN	843030SS	843030RT	843030LT	843030ST
96X30X30H	963030SL	963030SD	963030BB	963030BN	963030SS	963030RT	963030LT	963030ST

Bench Depth 30", Bench Height 36"

	SL	SD	BB	BN	SS	RT	LT	ST
36X30X36H	363036SL	363036SD	363036BB	363036BN	363036SS	363036RT	363036LT	363036ST
48X30X36H	483036SL	483036SD	483036BB	483036BN	483036SS	483036RT	483036LT	483036ST
60X30X36H	603036SL	603036SD	603036BB	603036BN	603036SS	603036RT	603036LT	603036ST
72X30X36H	723036SL	723036SD	723036BB	723036BN	723036SS	723036RT	723036LT	723036ST
84X30X36H	843036SL	843036SD	843036BB	843036BN	843036SS	843036RT	843036LT	843036ST
96X30X36H	963036SL	963036SD	963036BB	963036BN	963036SS	963036RT	963036LT	963036ST

Bench Depth 36", Bench Height 30"

	SL	SD	BB	BN	SS	RT	LT	ST
36X36X30H	363630SL	363630SD	363630BB	363630BN	363630SS	363630RT	363630LT	363630ST
48X36X30H	483630SL	483630SD	483630BB	483630BN	483630SS	483630RT	483630LT	483630ST
60X36X30H	603630SL	603630SD	603630BB	603630BN	603630SS	603630RT	603630LT	603630ST
72X36X30H	723630SL	723630SD	723630BB	723630BN	723630SS	723630RT	723630LT	723630ST
84X36X30H	843630SL	843630SD	843630BB	843630BN	843630SS	843630RT	843630LT	843630ST
96X36X30H	963630SL	963630SD	963630BB	963630BN	963630SS	963630RT	963630LT	963630ST

Bench Depth 36", Bench Height 36"

	SL	SD	BB	BN	SS	RT	LT	ST
36X36X36H	363636SL	363636SD	363636BB	363636BN	363636SS	363636RT	363636LT	363636ST
48X36X36H	483636SL	483636SD	483636BB	483636BN	483636SS	483636RT	483636LT	483636ST
60X36X36H	603636SL	603636SD	603636BB	603636BN	603636SS	603636RT	603636LT	603636ST
72X36X36H	723636SL	723636SD	723636BB	723636BN	723636SS	723636RT	723636LT	723636ST
84X36X36H	843636SL	843636SD	843636BB	843636BN	843636SS	843636RT	843636LT	843636ST
96X36X36H	963636SL	963636SD	963636BB	963636BN	963636SS	963636RT	963636LT	963636ST

Actual depth of 36"D laminate worksurface is 35.25"

ARLINK 7000 WORKBENCH WORKSURFACE OPTIONS

Standard Laminate Worksurface (SL)

- Particle board core with plastic laminate top and sides and phenolic backing sheet 1 3/8" with waterfall front edge
- Standard colors are dove gray and antique white



Static Dissipative Worksurface (SD)

- Particle board core with dissipative laminate top and sides and phenolic backing sheet 1 3/8" with waterfall front edge
- Grounding bolt and 10' grounding cord with 1 megohm resistor included
- Standard colors are dove gray and almond



Butcher Block Worksurface-Sq Edge (BB), Bullnose (BN)

- Satin finish 1 3/4" thick hardwood
- Available in standard square edge or bullnose front edge



Stainless Steel over wood core (SS)

- Worksurface is constructed of durable heavy gauge, 304 stainless steel cover, fitted over top and sides of wood core, 1 13/16" thick



Galvanized Steel over wood core (ST)

- Worksurface is constructed of durable heavy gauge galvanized steel cover, fitted over top and sides of wood core, 1 13/16" thick



Lista Top (LT)

- 1 3/4" thick worksurface with MDF core and 3/8" sanded, oil resistant pressed wood, top and bottom



Phenolic Resin (RT)

- Phenolic resin worksurfaces are designed for laboratory applications, are non-porous, resistant to a large number of aggressive chemicals
- Easy to clean, disinfect and maintain
- Standard phenolic tops are black (contact your representative for other colors)
- 1" thick



ARLINK 7000 ALL PURPOSE WORKBENCH

"L" Configuration

Available in multiple sizes and with 2 piece top or with 3 piece top with diagonal corner piece. Two piece tops are all square edge. Three piece tops in laminate and butcher block have front radius edge. Both may be assembled with left hand or right hand orientation.

This configuration eliminates the knee space interference of the bench leg that occurs when two independent benches are aligned in the "L" configuration.



"L" CONFIGURATION WITH 2 PIECE TOP

TOP MATERIAL	SL	SD	BB	SS	RT	LT
60X66X30X30H	60663030-2SL	60663030-2SD	60663030-2BB	60663030-2SS	60663030-2RT	60663030-2LT
60X72X30X30H	60723030-2SL	60723030-2SD	60723030-2BB	60723030-2SS	60723030-2RT	60723030-2LT
60X78X30X30H	60783030-2SL	60783030-2SD	60783030-2BB	60783030-2SS	60783030-2RT	60783030-2LT
72X66X30X30H	72663030-2SL	72663030-2SD	72663030-2BB	72663030-2SS	72663030-2RT	72663030-2LT
72X72X30X30H	72723030-2SL	72723030-2SD	72723030-2BB	72723030-2SS	72723030-2RT	72723030-2LT
72X78X30X30H	72783030-2SL	72783030-2SD	72783030-2BB	72783030-2SS	72783030-2RT	72783030-2LT
72X90X30X30H	72903030-2SL	72903030-2SD	72903030-2BB	72903030-2SS	72903030-2RT	72903030-2LT
84X66X30X30H	84663030-2SL	84663030-2SD	84663030-2BB	84663030-2SS	84663030-2RT	84663030-2LT
84X72X30X30H	84723030-2SL	84723030-2SD	84723030-2BB	84723030-2SS	84723030-2RT	84723030-2LT
84X78X30X30H	84783030-2SL	84783030-2SD	84783030-2BB	84783030-2SS	84783030-2RT	84783030-2LT
84X90X30X30H	84903030-2SL	84903030-2SD	84903030-2BB	84903030-2SS	84903030-2RT	84903030-2LT



"L" CONFIGURATION WITH 3 PIECE TOP

TOP MATERIAL	SL	SD	BB	BN	RT
60X66X30X30H	60663030-3SL	60663030-3SD	60663030-3BB	60663030-3BN	60663030-3RT
60X72X30X30H	60723030-3SL	60723030-3SD	60723030-3BB	60723030-3BN	60723030-3RT
60X78X30X30H	60783030-3SL	60783030-3SD	60783030-3BB	60783030-3BN	60783030-3RT
72X66X30X30H	72663030-3SL	72663030-3SD	72663030-3BB	72663030-3BN	72663030-3RT
72X72X30X30H	72723030-3SL	72723030-3SD	72723030-3BB	72723030-3BN	72723030-3RT
72X78X30X30H	72783030-3SL	72783030-3SD	72783030-3BB	72783030-3BN	72783030-3RT
72X90X30X30H	72903030-3SL	72903030-3SD	72903030-3BB	72903030-3BN	72903030-3RT
84X66X30X30H	84663030-3SL	84663030-3SD	84663030-3BB	84663030-3BN	84663030-3RT
84X72X30X30H	84723030-3SL	84723030-3SD	84723030-3BB	84723030-3BN	84723030-3RT
84X78X30X30H	84783030-3SL	84783030-3SD	84783030-3BB	84783030-3BN	84783030-3RT
84X90X30X30H	84903030-3SL	84903030-3SD	84903030-3BB	84903030-3BN	84903030-3RT

"L" Configuration with 3 Piece Top

ARLINK 7000 WORKBENCH CASTERS & LEG EXTENDERS

LEG EXTENDERS

Leg Extenders

- Allow nominal height adjustment of 6" on 2" increments
- Extender for 30" high workbench allows extended heights of 32", 34" or 36" overall height
- Extender for 36" high workbench allows extended heights of 38", 40" or 42" overall height
- Can not be used with caster kits



LEG EXTENDERS

LEG EXTENDERS (SET OF 4)	7Z30LE	6" ht adjustment in 2" increments
LEG EXTENDERS (SET OF 6)	7Z60LE	6" ht adjustment in 2" increments

CASTERS

Standard Casters

- Set of casters used to add mobility
- Swivel stem casters are 5" x 1 1/4" and replace glides which come with stationary legs
- Increases overall nominal height by 6"
- Includes 2 swivel and 2 locking swivel casters



STANDARD CASTERS

CASTERS	7M1000	adds 6" to bench height
---------	--------	-------------------------

Leveling Casters

- Easy moving, low vibration, leveling caster
- Once in position the foot pad is lowered using the manual knob or optional ratcheting mechanism
- Lifts the wheel off the floor making the bench completely stationary



LEVELING CASTERS

LEVELING CASTERS KNOB ADJ	7M5000	3-1/4" 81.8mm
LEVELING CASTERS RATCHET ADJ	7M6000	3-1/4" 81.8mm

Lab Style Casters

- Includes 2 swivel and 2 locking swivel casters
- Soft and quiet rolling with good chemical, wear and impact resistance
- Made of natural nylon, with 30% fiberglass and double ball raceway



LAB STYLE CASTERS

LAB STYLE CASTER	7M7000	adds 6" to bench height
------------------	--------	-------------------------

Castors with Leg Extenders

- Standard and lab style casters can be used with leg extenders
- Allows 6" of height adjustment in 2" increments



CASTERS WITH LEG EXTENDERS

CASTERS WITH LEG EXTENDERS	7M2000	adds 6" to bench height plus addition 6" of ht adjustment in 2" increments
----------------------------	--------	--

ARLINK 7000 WORKBENCH ACCESSORIES

Under Shelf

- For extra storage space under your benches
- 12" and 18" undershelves mount to leg braces



	36	48	60	72	84	96
12"	7Z3612US	7Z4812US	7Z6012US	7Z7212US	7Z8412US	7Z9612US
18"	7Z3618US	7Z4818US	7Z6018US	7Z7218US	7Z8418US	7Z9618US

Fixed Heavy Gauge Footrest

- Channel steel footrest fastens to leg braces



	36	48	60	72	84	96
	7E36FR	7E48FR	7E60FR	7E72FR	7E84FR	7E96FR

Back And End Stops

- Steel stops fasten to worksurface to provide back and end stops
- Stops extend approx. 4" above workbench top
- End stops are 30" deep and have rounded front corners
- Back stop can also be attached to riser shelf



	36	48	60	72	84	96
BACK AND END STOPS	36ES	48BES	60BES	72BES	84BES	96BES
BACK STOP ONLY	7J36BS	7J48BS	7J60BS	7J72BS	7J84BS	7J96BS

Outlet Strip

- Surface mounts to top or bottom of worksurface
- Lighted on/off switch
- Includes 6' power cord and circuit breaker
- Painted silver finish



PART NO.	DESCRIPTION
7H48EOP	48", 8 outlets, 15 Amp

ARLINK 7000 AND 8000 WORKBENCH ABOVE-WORKSURFACE ACCESSORIES

Riser Shelf With Box Supports

- 14" (36 cm) deep shelves are finished in either standard laminate, static dissipative laminate or butcher block to match specified worksurface
- Steel box supports are 19" (48 cm) high and 11" (28 cm) deep



	36	48	60	72	84	96
STANDARD LAMINATE	361419SL	481419SL	601419SL	721419SL	841419SL	961419SL
STATIC DISSIPATIVE LAMINATE	361419SD	481419SD	601419SD	721419SD	841419SD	961419SD
BUTCHER BLOCK	361419BB	481419BB	601419BB	721419BB	841419BB	961419BB
STAINLESS STEEL	361419SS	481419SS	601419SS	721419SS	841419SS	961419SS
GALVANIZED STEEL	361419ST	481419ST	601419ST	721419ST	841419ST	961419ST
PHENOLIC RESIN	361419RT	481419RT	601419RT	721419RT	841419RT	961419RT

Electrical Panel Insert For Box Support

- The panel insert includes illuminated 15 Amp circuit breaker, 4 duplex receptacles and 7.5' power cord
- Electrical panels can be used on one or both shelf supports and can be purchased with riser shelf or added later
- CSA listed
- 20 Amp and GFCI available on request



PART NO. _____
7Z19EP-□

LED Undershelf Light

- Anodized aluminum housing
- Polycarbonate lens & end caps
- 3 Position switch (high/low/off)
- Magnetic and swivel mounting
- CRI 85
- Color Temp 5000K
- Lumens:
23" = 1200 lm
34" = 1800 lm
45" = 2500 lm



LED UNDERSHELF LIGHT	23"	34"	45"
	7Z23LED	7Z34LED	7Z45LED
MAGNETIC MOUNTING BRACKETS	7ZLED-M		
SWIVEL MOUNTING BRACKETS	7ZLED-S		
CORD CLIPS	7ZLED-C		

HANGING DRAWERS

Hanging Drawer

- Steel drawer mounts under worksurface, and can slide to any horizontal position
- Includes steel ball bearing slides and recessed handles
- 100% full extension
- Each unit comes with a lock and 2 keys
- Keyed-alike and master locks are available. 16 3/4" wide

Shallow Lap Drawer

- 21 3/8" wide x 18 3/4" deep
- Lock not available
- Steel ball bearing slides and full length integrated handle



WORKSURFACE DEPTH	30" D	36"
HANGING CABINET, SINGLE 5 3/4"H DRAWER	7L1000	7L1001
HANGING CABINET, TWO 2 3/4"H DRAWERS	7L1200	7L1201
HANGING CABINET, TWO 5 3/4"D DRAWERS	7L5000	7L5001
HANGING CABINET, FOUR 2 3/4" H DRAWERS	7L1600	7L1601
HANGING CABINET, TWO 2 3/4"D, ONE 5 3/4"H DRAWERS	7L1400	7L1401
HANGING CABINET, ONE 5 3/4"H, ONE 13 15/15"D FILE DRAWERS	7L2000	7L2001
HANGING CABINET, THREE 5 3/4"H DRAWERS	7L3000	7L3001
HANGING CABINET, TWO 2 3/4"H, ONE 13 15/15"D FILE DRAWERS	7L1800	7L1801
HANGING CABINET, TWO 2 3/4"H DRAWERS, TWO 5 3/4"D DRAWERS	7L2100	7L2101
HANGING CABINET, SINGLE 13 15/15"H FILE DRAWER,	7L1100	7L1101
SHALLOW LAP DRAWER	7L8000	7L8001

DRAWER PULL OPTIONS

Hanging Cabinet Tech Drawer Pull (Chrome Color)	4875-CHRM
Hanging Cabinet Tech Drawer Pull (Brushed Silver)	4875-BRSH
Hanging Cabinet Tech Drawer Pull (Gloss Black)	4875-GBLK

Pelican® Drawer

- Secure storage for legal hanging files or personal effects, plus segmented tray for pencils, pens, paper clips, etc.
- Designed to allow easy clearance for worker's knees
- Thermo-formed polystyrene body with polyurethane drawer face
- Mounts under worksurface to worksurface support beams
- Includes concealed ball bearing slides and fully integrated locking system



WORKSURFACE DEPTH	30" D	36"
PELICAN DRAWER	7L6000	7L6001

THE VSI-8 SYSTEM

The VSI-8 System is designed to expand the efficiency of:

- Align® adjustable height workstations
- Lista technical electronic workstations
- Lista industrial workbenches
- Retrofit to existing workbenches

You can create highly productive and efficient work centers by adding above-worksurface work aids such as task lighting, storage shelves, power beams, parts bin rails, etc.

With the VSI-8 System, you're able to utilize the Arlink 8000 system's wide range of shelving and accessory options that easily attach to the vertical column without the need for tools, using the micro and macro slots on both sides of the upright columns (see page 298 for detailed descriptions).

The VSI-8 System is easily installed by in-house personnel and can be utilized as a single unit on a stand-alone bench, or linked together using our starter/adder system. VSI columns are double-sided, and one VSI may service two benches when benches are positioned back-to-back.



VSI-8 uprights and accessories mount onto any workbench worksurface to provide a complete accessory system. VSI-8 uprights' double-sided columns allow uprights and accessories to be shared between two benches (see below).

THE VSI-1 SYSTEM

The VSI-1 System is designed to expand the efficiency of any workbench, regardless of manufacturer. Frames are sturdy, heavy gauge steel, and are slotted front and back at 1" increments for mounting accessories. Starter frames consist of 2 upright posts and a horizontal rail. Adder sets consist of an additional upright and horizontal rail. Foot plate is 2 3/4" x 4".



NEW TRIM FEATURES & IMPROVEMENTS:

Trim profile has been changed to:

- Give the column a larger, more robust, appearance
- Increase the capacity for cord management
- Accommodate future addition of column mounted utility modules such as gas, air, power and data

Compatibility:

The new trim profile is backward compatible with all previous Arlink 8000 columns. There will be a spacing conflict with some older systems between column accessories such as privacy panels, louvered panels and pegboard panels and the variable angle shelf. New iterations of these accessories will be compatible with both old and new style trim.

Column Cap

The column cap has been redesigned to provide a more positive and secure attachment to the column. Material thickness has been increased and color will be matched to the steel paint color. The column cap is included on all columns 54" h or shorter and is optional on all other heights.

VSI-8 Column Trim Color Options

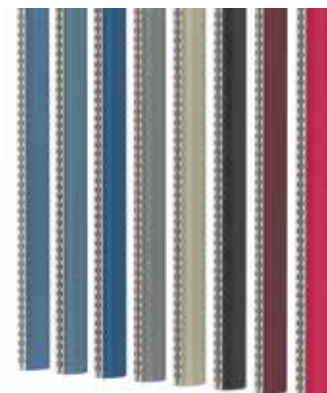

- Bright Blue (BB)
- Classic Blue (CB)
- Royal Blue (RB)
- Dark Gray (GR)
- Sand (SN)
- Black (BL)
- Burgundy (BUR)
- Red (NR)

VSI-8

Features sturdy 45" high, 1 1/4" wide, 4" deep, roll-formed steel columns that fasten to the bench top and are stabilized by a modesty panel.

Starter assembly includes:

- 2 columns, 4 trim strips
- 1 modesty panel and mounting hardware

Adder assembly includes:

- 1 mounting column, 2 trim strips,
- 1 modesty panel and mounting hardware
- Trim strip color can be chosen from the chart on page 196
- Foot plate for surface mount uprights is 5" x 3"
- Surface mount VSI-8 System width must be a minimum of 6" shorter than worksurface width



SURFACE MOUNT	24"	30"	36"	42"	48"	60"	72"
VSI-8 STARTER ASSEMBLY (45"H)	9412-24S	9412-30S	9412-36S	9412-42S	9412-48S	9412-60S	9412-72S
ADDER ASSEMBLY (45"H)	9412-24A	9412-30A	9412-36A	9412-42A	9412-48A	9412-60A	N/A
LOW PROFILE VSI-8 UPRIGHT SYSTEM (24"H)	PAIR-4086	SINGLE-4087					

Rear Mount VSI-8 for Align Bench

Features sturdy 45" high, 1 1/4" wide, 4" deep, roll-formed steel columns that mounts to rear frame of the Align bench and is stabilized by a modesty panel.

Starter assembly includes:

- 2 columns, 4 trim strips
- 1 modesty panel and mounting hardware

Adder assembly includes:

- 1 mounting column, 2 trim strips,
- 1 modesty panel and mounting hardware
- Trim strip color can be chosen from the chart on page 196
- Includes mounting brackets for Align bench
- Rear Mount VSI-8 Systems can be full width of the Align workstation base



REAR MOUNT FOR ALIGN SECTION WIDTH*	24"	30"	36"	42"	48"	60"	72"
STARTER ASSEMBLY	9ADJ-VSI-824S	9ADJ-VSI-830S	9ADJ-VSI-836S	9ADJ-VSI-842S	9ADJ-VSI-848S	9ADJ-VSI-860S	9ADJ-VSI-872S
ADDER ASSEMBLY	9ADJ-VSI-824A	9ADJ-VSI-830A	9ADJ-VSI-836A	9ADJ-VSI-842A	9ADJ-VSI-848A	N/A	N/A

*section width must be equal to or less than Align worksurface base width

VSI-1

Frames are sturdy, heavy gauge steel, and are slotted front and back at 1" increments for mounting accessories. Uprights are available in heights of 30" and 48". Footplate is 2 3/4" x 4".

Starter assembly includes:

- 2 uprights
- 1 horizontal rail and mounting hardware

Adder assembly includes:

- 1 uprights
- 1 horizontal rail and mounting hardware



VSI-1	24"	30"	36"	42"	48"	60"
STARTER ASSEMBLY (48"H)	7Z3011	7Z3001	7Z3002	7Z3013	7Z3003	7Z3004
ADDER ASSEMBLY (48"H)	7Z3012	7Z3006	7Z3007	7Z3014	7Z3008	7Z3009
STARTER ASSEMBLY (30"H)	7Z3011C30	7Z3001C30	7Z3002C30	7Z3013C30	7Z3003C30	7Z3004C30
ADDER ASSEMBLY (30"H)	7Z3012C30	7Z3006C30	7Z3007C30	7Z3014C30	7Z3008C30	7Z3009C30

ARLINK 8000® WORKSTATION SYSTEM

Arlink 8000® workstations give the user the greatest flexibility possible. Our unique Definite Positioning System®, numerous footprint configurations, and easy-to-assemble starter and adder sections, mean you can easily adapt and reconfigure your workstations as your needs evolve.

Definite Positioning System®

An innovative assembly concept which features one macro and two micro slots on each side of a high strength column, this approach greatly reduces the time and effort needed to attach components to the system, while making highly efficient use of space. Since columns are double-sided, a single column may be used by two back-to-back workstations, as well as adjacent sections.

Macro slots provide support for heavy-duty components, such as worksurfaces and shelving. In the case of adjacent workstation sections, the macro slot is utilized by both to save space and reduce system cost. Components that attach to the macro slots are vertically adjustable in 3" increments.

Micro slots provide support for lighter-duty components, such as power beams and parts bin rails. Micro slots are located to the left and right of the macro slot, and provide maximum component placement options. Components that attach to the micro slots are vertically adjustable in 1" increments.

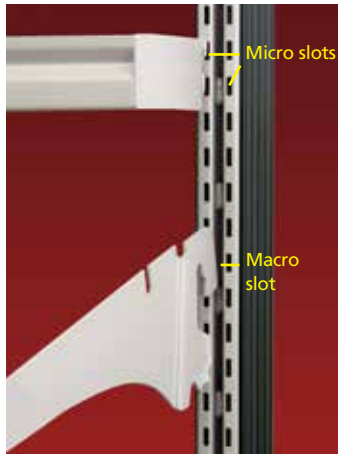

Brackets fit into either micro slots or macro slots.

Paint Colors

Paint colors for the Arlink® 8000 Modular Workstations are Light Gray and Sand. Bright Blue and Black are available with standard lead times based on production volume at time of order.



NEW TRIM FEATURES & IMPROVEMENTS:

Trim profile has been changed to:

- Give the column a larger, more robust, appearance
- To increase the capacity for cord management
- To accommodate future addition of column mounted utility modules such as gas, air, power and data

Compatibility:

- Larger trim is available in 8 trim colors and provides increased internal capacity for cord and utility management
- Backward compatible with all existing and previous Arlink® 8000 columns

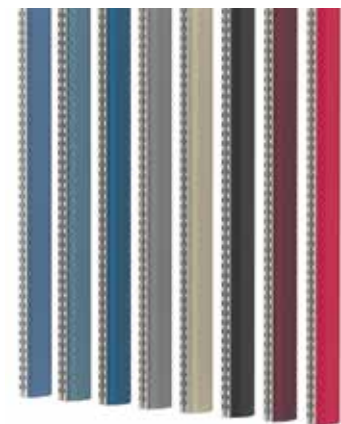

- Bright Blue (BB)
- Classic Blue (CB)
- Royal Blue (RB)
- Dark Gray (GR)
- Sand (SN)
- Black (BL)
- Burgundy (BUR)
- Red (NR)

ARLINK 8000 WORKSTATION CONFIGURATION OPTIONS

Floor space utilization

Arlink® 8000 workstations enable you to achieve maximum productivity per square foot. Our workstations can be designed in numerous configurations to meet any application. You can configure your workstations to suit your needs today, and as future needs evolve.

Many workstation configurations may also be ordered with mobile capabilities, enabling you to quickly and easily relocate entire workstation groupings.

Please contact your Lista representative for additional configuration options.

Conveyor workstations

The Arlink® 8000 family of conveyor workstation systems provides cost-effective, high-efficiency workflow management throughout your entire production stream, between automatic machines and in operations including:

- Manual assembly areas
- Inspection
- Testing
- Rework
- Packaging

Systems are available with single- or multi-level conveyor or easily integrated with the conveyor of your choice.

In-line Configuration



In-line Back-to-Back Configuration

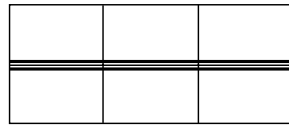

L Configuration

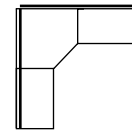

T Configuration

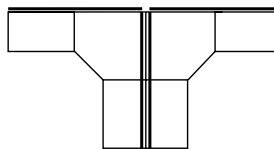

U Configuration

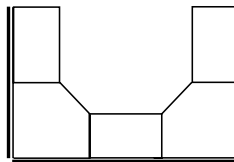

X Configuration

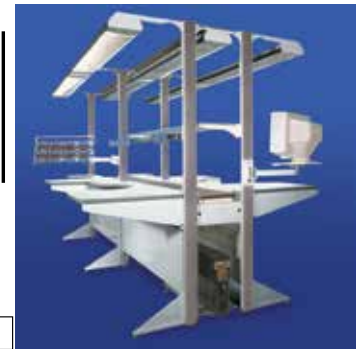
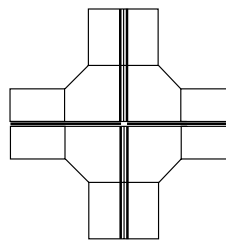

Select from Arlink® 8000 workstation options to best optimize workflow management, including workspaces and accessories (task lighting, power, air and data beams, shelving, parts bin racks, etc.).

Single-Sided – operator faces conveyor with standard worksurface

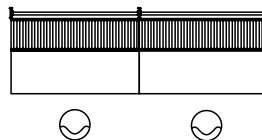

Double-Sided – operator faces conveyor with standard worksurface

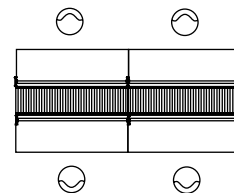

Double-Sided – operator faces conveyor with scalloped worksurface

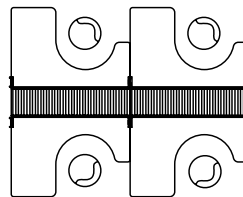

Double-Sided – operator at 90° to conveyor with standard worksurface

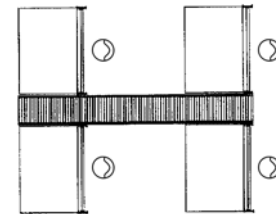

ARLINK 8000 EASY-ORDER COMBINATIONS

The workstation components shown on this page are preconfigured to include our most popular and versatile Arlink® 8000 workstation styles.

Arlink® 8000 workstations consist of a starter section, and as many adder sections as you need for your application.

Select from single- or double-sided starters, adders, or corners in all standard section widths and heights. Easy-Order sections include all accessories shown in the charts to the right. To order additional accessories, please see pages 174–176.

Single-Sided Starter

Assembly Includes:

- 1 Starter Assembly
- 2 Outriggers
- 1 Worksurface Assembly
- 1 Single-Sided Power Beam (15 Amp)
- 1 Open Wire Shelf Assembly, 12" Depth
- 2 Bulb Light Bulb Fixture Assembly



SINGLE-SIDED STARTERS - STANDARD LAMINATE, 30" DEPTH

COLUMN HEIGHT	30"	36"	48"	60"	72"
54"	9A-SS305430SL	9A-SS365430SL	9A-SS485430SL	9A-SS605430SL	9A-SS725430SL
72"	9A-SS307230SL	9A-SS367230SL	9A-SS487230SL	9A-SS607230SL	9A-SS727230SL
84"	9A-SS308430SL	9A-SS368430SL	9A-SS488430SL	9A-SS608430SL	9A-SS728430SL

SINGLE-SIDED STARTERS—DISSIPATIVE LAMINATE, 30" DEPTH

COLUMN HEIGHT	30"	36"	48"	60"	72"
54"	9A-SS305430SD	9A-SS365430SD	9A-SS485430SD	9A-SS605430SD	9A-SS725430SD
72"	9A-SS307230SD	9A-SS367230SD	9A-SS487230SD	9A-SS607230SD	9A-SS727230SD
84"	9A-SS308430SD	9A-SS368430SD	9A-SS488430SD	9A-SS608430SD	9A-SS728430SD

Single-Sided Adder

Assembly Includes:

- 1 Adder Assembly
- 1 Outrigger
- 1 Worksurface Assembly
- 1 Single-Sided Power Beam (15 Amp)
- 1 Open Wire Shelf Assembly, 12" Depth
- 2 Bulb Light Bulb Fixture Assembly



SINGLE-SIDED ADDERS - STANDARD LAMINATE, 30" DEPTH

COLUMN HEIGHT	30"	36"	48"	60"	72"
54"	9A-SA305430SL	9A-SA365430SL	9A-SA485430SL	9A-SA605430SL	9A-SA725430SL
72"	9A-SA307230SL	9A-SA367230SL	9A-SA487230SL	9A-SA607230SL	9A-SA727230SL
84"	9A-SA308430SL	9A-SA368430SL	9A-SA488430SL	9A-SA608430SL	9A-SA728430SL

SINGLE-SIDED ADDERS — DISSIPATIVE LAMINATE, 30" DEPTH

COLUMN HEIGHT	30"	36"	48"	60"	72"
54"	9A-SA305430SD	9A-SA365430SD	9A-SA485430SD	9A-SA605430SD	9A-SA725430SD
72"	9A-SA307230SD	9A-SA367230SD	9A-SA487230SD	9A-SA607230SD	9A-SA727230SD
84"	9A-SA308430SD	9A-SA368430SD	9A-SA488430SD	9A-SA608430SD	9A-SA728430SD

Single-Sided Corner Adder

Assembly Includes:

- 1 Adder Assembly
- 1 Outrigger
- 1 Worksurface Assembly
- 1 Single-Sided Power Beam (15 Amp)
- 1 Open Wire Shelf Assembly, 12" Depth
- 2 Bulb Light Bulb Fixture Assembly



SINGLE-SIDED CORNER ADDERS - STANDARD LAMINATE, 30" DEPTH

COLUMN HEIGHT	36"
54"	9A-SC365430SL
72"	9A-SC367230SL
84"	9A-SC385430SL

SINGLE-SIDED CORNER ADDERS —DISSIPATIVE LAMINATE, 30" DEPTH

COLUMN HEIGHT	36"
54"	9A-SC365430SD
72"	9A-SC367230SD
84"	9A-SC368430SD

ARLINK 8000 EASY-ORDER COMBINATIONS (CONT)

Double-Sided Starter

Assembly Includes:

- 1 Starter Assembly
- 4 Outriggers
- 2 Worksurface Assemblies
- Double-Sided Power Beam (15 Amp)
- 2 Open Wire Shelf Assemblies, 12" Depth
- 2 Bulb Light Bulb Fixture Assembly



DOUBLE-SIDED STARTERS - STANDARD LAMINATE, 30" DEPTH

COLUMN HEIGHT	30"	36"	48"	60"	72"
54"	9A-DS305430SL	9A-DS365430SL	9A-DS485430SL	9A-DS605430SL	9A-DS725430SL
72"	9A-DS307230SL	9A-DS367230SL	9A-DS487230SL	9A-DS607230SL	9A-DS727230SL
84"	9A-DS308430SL	9A-DS368430SL	9A-DS488430SL	9A-DS608430SL	9A-DS728430SL

SINGLE-SIDED STARTERS—DISSIPATIVE LAMINATE, 30" DEPTH

COLUMN HEIGHT	30"	36"	48"	60"	72"
54"	9A-DS305430SD	9A-DS365430SD	9A-DS485430SD	9A-DS605430SD	9A-DS725430SD
72"	9A-DS307230SD	9A-DS367230SD	9A-DS487230SD	9A-DS607230SD	9A-DS727230SD
84"	9A-DS308430SD	9A-DS368430SD	9A-DS488430SD	9A-DS608430SD	9A-DS728430SD

Double-Sided Adder

Assembly Includes:

- 1 Adder Assembly
- 2 Outriggers
- 2 Worksurface Assemblies
- 1 Double-Sided Power Beam (15 Amp)
- 2 Open Wire Shelf Assemblies, 12" Depth
- 2 Bulb Light Bulb Fixture Assembly



DOUBLE-SIDED ADDERS - STANDARD LAMINATE, 30" DEPTH

COLUMN HEIGHT	30"	36"	48"	60"	72"
54"	9A-DA305430SL	9A-DA365430SL	9A-DA485430SL	9A-DA605430SL	9A-DA725430SL
72"	9A-DA307230SL	9A-DA367230SL	9A-DA487230SL	9A-DA607230SL	9A-DA727230SL
84"	9A-DA308430SL	9A-DA368430SL	9A-DA488430SL	9A-DA608430SL	9A-DA728430SL

SINGLE-SIDED ADDERS—DISSIPATIVE LAMINATE, 30" DEPTH

COLUMN HEIGHT	30"	36"	48"	60"	72"
54"	9A-DA305430SD	9A-DA365430SD	9A-DA485430SD	9A-DA605430SD	9A-DA725430SD
72"	9A-DA307230SD	9A-DA367230SD	9A-DA487230SD	9A-DA607230SD	9A-DA727230SD
84"	9A-DA308430SD	9A-DA368430SD	9A-DA488430SD	9A-DA608430SD	9A-DA728430SD

Double Sided Corner Adder

Assembly includes:

- 1 Starter Assembly
- 2 Outriggers
- 2 Worksurface Assemblies
- 1 Double-Sided Power Beam (15 Amp)
- 2 Open Wire Shelf Assemblies, 12" Depth
- 2 Bulb Light Bulb Fixture Assembly



DOUBLE-SIDED ADDERS - STANDARD LAMINATE, 30" DEPTH

COLUMN HEIGHT	36"
54"	9A-DC365430SL
72"	9A-DC367230SL
84"	9A-DC368430SL

SINGLE-SIDED ADDERS—DISSIPATIVE LAMINATE, 30" DEPTH

COLUMN HEIGHT	36"
54"	9A-DC365430SD
72"	9A-DC367230SD
84"	9A-DC368430SD

BUILD YOUR OWN WORKSTATION

Designing a custom Arlink 8000® workstation is a simple and straight forward process.

Start by selecting the structural elements (starter and adder assemblies), add outriggers, choose worksurface(s), and add the accessories that fulfill your needs.

In addition to the column heights shown, columns can be custom cut to any size you request.

1. Select starter assembly (length and height)
2. Select adder assemblies (length and height)
3. Select outriggers or Select mobile starter base
4. Select appropriate worksurface assemblies
5. Select accessories



STARTER ASSEMBLY COLUMN HEIGHT	24"	30"	36"	48"	60"	72"
54"	9829	9692	9897	9896	9601	9702
72"	9831	9694	9901	9900	9600	9700
84"	9833	9696	9903	9902	9603	9704

ADDER ASSEMBLY COLUMN HEIGHT	24"	30"	36"	48"	60"	72"
54"	9830	9693	9899	9898	9606	9703
72"	9832	9695	9906	9905	9605	9701
84"	9834	9697	9908	9904	9608	9705

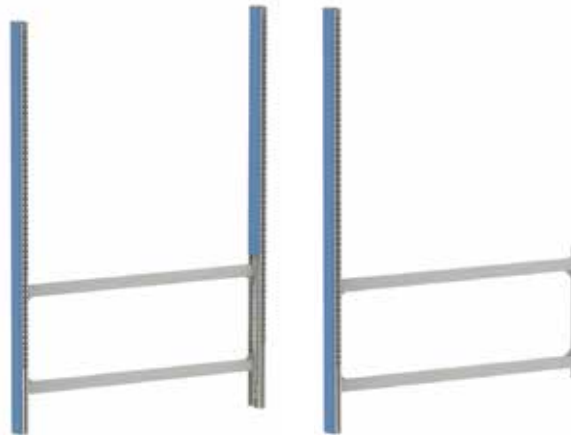

STARTER ASSEMBLY - OPEN STABILIZER COLUMN HEIGHT	24"	30"	36"	48"	60"	72"
54"	09829	09692	09897	09896	09601	09702
72"	09831	09694	09901	09900	09600	09700
84"	09833	09696	09903	09902	09603	09704

ADDER ASSEMBLY - OPEN STABILIZER COLUMN HEIGHT	24"	30"	36"	48"	60"	72"
54"	09830	09693	09899	09898	09606	09703
72"	09832	09695	09906	09905	09605	09701
84"	09834	09697	09908	09904	09608	09705

BUILD YOUR OWN WORKSTATION



Outriggers

OUTRIGGERS

22" (24"-30" W/SFC)	8066
30" (36" W/SFC)	8073
15" (SHELVING & CORNERS)	8078



Mobile Base Starter

MOBILE BASE-SINGLE SIDED

	24"	30"	36"	48"	60"	72"
STARTER	9997SS	9313SS	9969SS	9968SS	9668SS	9768SS
ADDER	9997SA	9313SA	9969SA	9968SA	9668SA	9768SA



Mobile Base Adder

Column Cap

- Redesigned to provide a more positive and secure attachment to the column
- Material thickness has been increased and color will be matched to the steel paint color
- Included on all columns 54"h or shorter and is optional on all other heights



Column Cap

PART NO.
8006

Back Stops

- Steel back stop prevents items from rolling off worksurface.
- 3" high.
- Mounts in micro slots, adjusts vertically in 1" increments.



BACK STOPS LENGTH

BACK STOPS LENGTH	PART NO.
24"	8962
30"	8449
36"	8461
48"	8463
60"	8466
72"	8468

ARLINK 8000 WORKSTATION WORKSURFACES

Plastic Laminate Worksurface Assemblies

Worksurface is constructed of 1" thick medium density particle board covered on top and all sides with non-glare matte finish plastic laminate. Assembly includes 2 worksurface support brackets and 2 worksurface support beams.

Color:

- Dove gray
- Antique white

Static Dissipative Laminate Worksurface Assemblies

Worksurface is the same as the plastic laminate worksurface, but with plastic laminate that provides a controlled path to ground for the dissipation of static electricity. The worksurface is provided with a grounding kit that must be used to provide proper protection for components and personnel. Static dissipative value for the material is 10⁶-10⁹. Assembly includes 2 worksurface support brackets and 2 worksurface support beams.

Color:

- Dove gray
- Almond

Also available:

- Butcher block (1 1/4" thick)
- Phenolic resin (1" thick)
- Stainless steel (1 1/8" thick)



WORKSURFACE ASSEMBLY-STANDARD LAMINATE

	24"	30"	36"	48"	60"	72"
24"	9251	9551	9351	9451	9651	9751
28"	9815	9729	9924	9923	9620	9715
30"	9818	9730	95A101	95A105	95A109	95A113
36"	9813	9733	95A104	95A108	95A112	95A116

CORNER WORKSURFACE ASSEMBLY-ADJACENT WORKSURFACE-SQ. BACK, STANDARD LAMINATE

	24"	28"	30"	36"
30" MODULE	9950	9722	9748	N/A
36" MODULE	9951	9812	95A200	95A203
48" MODULE	9956	9864	95A224	95A227
ROUND BACK CORNER	9966	9806	95A216	95A219
REAR SUPPORT POST	9094			

WORKSURFACE ASSEMBLY

-ESD LAMINATE

	24"	30"	36"	48"	60"	72"
24"	9251SD	9551SD	9351SD	9451SD	9651SD	9751SD
28"	9816	9754	9994	9992	9622	9716
30"	9819	9755	95A155	95A159	95A163	95A167
36"	9827	9758	95A158	95A162	95A166	95A170

CORNER WORKSURFACE ASSEMBLY-ADJACENT WORKSURFACE-ESD LAMINATE

	24"	28"	30"	36"
30" MODULE	9950SD	9722SD	9748SD	N/A
36" MODULE	9951SD	9814	95A204	95A207
48" MODULE	9956SD	9865	95A228	95A231
ROUND BACK CORNER	9966SD	9808	95A220	95A223
REAR SUPPORT POST	9094			



WORKSURFACE ASSEMBLY-BUTCHER BLOCK

	24"	30"	36"	48"	60"	72"
24"	9251BB	9551BB	9351BB	9451BB	9651BB	9751BB
28"	9815BB	9729BB	9924BB	9923BB	9620BB	9715BB
30"	9818BB	9730BB	95A101BB	95A105BB	95A109BB	95A113BB
36"	9813BB	9733BB	95A104BB	95A108BB	95A112BB	95A116BB

CORNER WORKSURFACE ASSEMBLY-ADJACENT WORKSURFACE DEPTH-BUTCHER BLOCK

	24"	28"	30"	36"
30" X 30"	9950BB	9722BB	9748BB	N/A
36" X 36"	9951BB	9812BB	95A200BB	95A203BB
48" X 48"	9956BB	9864BB	95A224BB	95A227BB
ROUND BACK CORNER	9966BB	9806BB	95A216BB	95A219BB
REAR SUPPORT POST FOR SQ. BACK CORNER	9094			

HANGING DRAWERS AND CPU HOLDERS

Hanging Drawer

- Steel drawer mounts under worksurface, and can slide to any horizontal position
- Includes steel ball bearing slides and recessed handles
- 100% full extension
- Each unit comes with a lock and 2 keys
- Keyed-alike and master locks are available. 16 3/4" wide

Lap Drawer/Pencil Drawer

- 21 3/8" wide x 18 3/4" deep
- Lock not available
- Steel ball bearing slides and full length integrated handle



WORKSURFACE DEPTH

HANGING CABINET, TWO 2 3/4"D, ONE 5 3/4"H DRAWERS	4841
HANGING CABINET, FOUR 2 3/4" H DRAWERS	4842
HANGING CABINET, TWO 2 3/4"H, ONE 13 15/15"D FILE DRAWERS	4855
HANGING CABINET, TWO 2 3/4"H DRAWERS, TWO 5 3/4"D DRAWERS	4856
HANGING CABINET, SINGLE 5 3/4"H DRAWER	8619
HANGING CABINET, TWO 2 3/4"H DRAWERS	8626
HANGING CABINET, SINGLE 13 15/15"H FILE DRAWER,	8634
HANGING CABINET, TWO 5 3/4"H DRAWERS	8639
HANGING CABINET, ONE 5 3/4"H, ONE 13 15/15"D FILE DRAWERS	8658
HANGING CABINET, THREE 5 3/4"H DRAWERS	8664
LAP DRAWER	4850

DRAWER PULL OPTIONS

Hanging Cabinet Tech Drawer Pull (Chrome Color)	4875-CHRM
Hanging Cabinet Tech Drawer Pull (Brushed Silver)	4875-BRSH
Hanging Cabinet Tech Drawer Pull (Gloss Black)	4875-GBLK

Pelican® Drawer

- Secure storage for legal hanging files or personal effects, plus segmented tray for pencils, pens, paper clips, etc.
- Designed to allow easy clearance for worker's knees
- Thermo-formed polystyrene body with polyurethane drawer face
- Mounts under worksurface to worksurface support beams
- Includes concealed ball bearing slides and fully integrated locking system



PART NO.

8845

ARLINK 8000 FLOW RACKS

Flow racks can be used to stage and deliver parts utilizing gravity, reducing material handling time and costs. Bins or totes are loaded on flow rack frames from the rear, and as operators remove one from the front, a new bin glides forward on rollers. Similarly, flow rack frames can be inclined away from an operator to allow removal of completed work.

Flow racks are constructed utilizing the same Starter and Adder system common to all Arlink 8000 workstations. Worksurface assemblies and accessories as shown in this catalog can be added to create a complete parts presentation and integrated workstation system. Ball transfer tables, other material handling worksurfaces (see pages 171–172) or conveyors (see page 198) may also be integrated into the worksurface as needed. Flow racks can be made mobile by the addition of caster sets.

Flow rack sections may be joined side by side, using Starter and Adder assemblies to achieve any overall length and combination of section sizes.

Arlink 8000 Flow Racks

- Arlink 8000 flow racks sections are available in 4 standard widths from 30" to 60"
- Flow racks are height adjustable in 1" increments
- The flow rack angle is adjustable, 1400 lb. weight capacity

Arlink 8000 Flow Rack Starter Assemblies

- Consists of 2 starter assemblies, 2 outriggers, 1 flow rack shelf assembly and 4 connectors

Arlink 8000 Flow Rack Adder Assemblies

- Consists of 1 adder assembly, 1 outrigger, 1 flow rack shelf assembly and 2 connectors

Arlink 8000 Flow Rack Shelf Assemblies

- Shelf assembly includes roller tracks and guides as shown
- 3" high, 48" deep, 600 lb. weight capacity
- For additional roller tracks and guides, see chart to right

Arlink 8000 Flow Rack Shelf Accessories

- Shelves are slotted on 1 1/2" increments to accept roller tracks and guides
- Guides separate sections
- Rollers are 1 1/16" wide; tracks are 1" wide
- Two rollers are recommended for rows up to 15" wide, and 3 or more for wider rows



Arlink 8000 Flow Rack Starter Assemblies

PART NO.	SIZE
72" HIGH	
FRS3072	30" wide x 48" deep
FRS3672	36" wide x 48" deep
FRS4872	48" wide x 48" deep
FRS6072	60" wide x 48" deep

84" HIGH	
FRS3084	30" wide x 48" deep
FRS3684	36" wide x 48" deep
FRS4884	48" wide x 48" deep
FRS6084	60" wide x 48" deep

Arlink 8000 Flow Rack Adder Assemblies

PART NO.	SIZE
72" HIGH	
FRA3072	30" wide x 48" deep
FRA3672	36" wide x 48" deep
FRA4872	48" wide x 48" deep
FRA6072	60" wide x 48" deep

84" HIGH	
FRA3084	30" wide x 48" deep
FRA3684	36" wide x 48" deep
FRA4884	48" wide x 48" deep
FRA6084	60" wide x 48" deep

Arlink 8000 Flow Rack Shelf Assemblies

PART NO.	WIDTH	INCLUDES
FR30	30"	4 roller tracks, 1 guide
FR36	36"	4 roller tracks, 1 guide
FR48	48"	6 roller tracks, 2 guides
FR60	60"	6 roller tracks, 2 guides

Arlink 8000 Flow Rack Shelf Accessories

PART NO.	DESCRIPTION
FRTR	roller track
FRGU	roller guide
FRCP	replacement clip

ARLINK 8000 UTILITY AND PARTS CARTS

Single- or double-sided modular carts can be configured with any combination of shelves, parts bins, utility bins, etc. to meet your exact needs. All are constructed using Lista's standard Arlink 8000 column to allow complete interchangeability of components with workstations.

Utility and Parts Carts

- 54" high carts feature 2 wheel-locking and 2 non-locking casters, 3 1/2" diameter
- Wheels are rubber, non-marking

Accepts:

- Shelves – maximum shelf depth for parts cart is 14"
- Pegboard, louvered, reversible and modesty panels
- Bin rails
- Power, air and data beams
- Pivoting accessories



Utility and Parts Carts

PART NO.	SECTION LENGTH
SINGLE-SIDED	
8326SS	30"
8915SS	36"
8964SS	48"
DOUBLE-SIDED	
8326DS	30"
8915DS	36"
8964DS	48"



ARLINK 7000 AND 8000 SHELVES

Open Wire Shelf

- Welded steel wire shelf has chrome plated finish
- Adjusts from horizontal to 15° and 30° inclination
- Includes front lip (can be oriented up or down)
- Weight capacity 150 lbs.
- Available with micro and macro slot brackets



Open Wire Shelf-Macro Slot

VSI-8 COLUMNS	30"	36"	48"	60"	72"
12" D	8884	8927	8925	8625	8725
9"D LAB	4581	4381	4481	4681	4781

Open Wire Shelf-Micro Slot

VSI-8 AND VSI-1 COLUMNS	30"	36"	48"	60"	72"
12" D	7Z1057	7Z1058	7Z1059	7Z1060	7Z1061
9"D LAB	4282	4382	4482	4682	4782

Light Duty Adjustable Steel Shelf

- Mount flat or at a 15° angle
- Mount with the lip to the front or back
- 100 lb. weight capacity
- Available only with micro slot bracket



Light Duty Shelf

VSI-8 AND VSI-1 COLUMNS	24"	30"	36"	42"	48"	60"
12"D	7Z1166	7Z1167	7Z1168	7Z1177	7Z1169	7Z1170
15"D	7Z1178	7Z1172	7Z1173	7Z1182	7Z1174	7Z1175

Steel Shelf

- Adjusts from horizontal to 15 degree and 30 degree inclination with macro brackets and from horizontal to 15 degree with micro brackets.
- Marco slot shelves have weight capacity of 300 lbs.
- Micro slot shelves have weight capacity of 150 lbs.



Steel Shelf-Macro Slot

VSI-8 COLUMNS	24"	30"	36"	42"	48"	60"	72"
12"D	4260	4560	4360	4160	4460	4660	4760
16"D	4261	4561	4361	4161	4461	4661	4761
20"D	4262	4562	4362	4162	4462	4662	4762

Steel Shelf-Micro Slot

VSI-8 AND VSI-1 COLUMNS	24"	30"	36"	42"	48"	60"	72"
12"D	7Z2021	7Z2022	7Z2023	7Z2024	7Z2025	7Z2026	7Z2027
16"D	7Z2031	7Z2032	7Z2033	7Z2034	7Z2035	7Z2036	7Z2037
20"D	7Z2041	7Z2042	7Z2043	7Z2044	7Z2045	7Z2046	7Z2047

Shelf Lips

	24"	30"	36"	42"	48"	60"	72"
	4265	4565	4365	4165	4465	4665	4765

Steel Shelf Dividers

	12"D	16"D	20"D
8"	4120-12	4120-16	4120-20
12"	4121-12	4121-16	4121-20

Variable Angle Shelf

- Shelf mounts in forward or set back position
- Adjusts variably from totally flat to 25° angle and has a full perimeter lip
- 150 lb. capacity
- Shelf without lip is similar to variable angle shelf but includes pre-punched holes to accept vertical wire dividers
- Mounts in micro slots, adjusts vertically in 1" increments



Variable Angle Shelf

VSI-8 AND VSI-1 COLUMNS	24"	30"	36"	42"	48"	60"
18"D	8232	8312	8328	8342	8327	8497
24"D	8233	8314	8355	8378	8354	N/A

ARLINK 7000 AND 8000 WORKSTATION LIGHTING ACCESSORIES

Dual Lamp Fluorescent Light Assembly

- Economical twin tube fluorescent light fixture
- Uses economical T-8 lamps and electronic ballasts and come with a 9ft power cord
- Color temperature is 4100K
- Output: 80 footcandles (861 lumens)



	30"	36"	42"	48"	60"	72"
2 BULB T8 FLUORESCENT 19" MICRO BRACKET	9511L	9533L	9679L	9534L	9655L	9784L
2 BULB T8 FLUORESCENT 26" MICRO BRACKET	9511XL	9533XL	9679XL	9534XL	9655XL	9784XL

LED Overhead Light Assembly

- Overhead task lighting is available with a choice of 2 micro slot mounting brackets, 19" and 26"
- The 26" bracket is recommended for deeper worksurfaces and when being used over the deeper shelves
- Color Temp 5000K
- CRI 90
- Average Output 1500 Lumens (measured at surface - light 41" above)



	30"	36"	42"	48"	60"	72"
LED FIXTURE 19" MICRO BRACKET	8524L	8527L	8419L	8531L	8621L	8788L
FIXTURE 26" MICRO BRACKET	8524XL	8527XL	8419XL	8531XL	8621XL	8788XL

Switchable 4 Lamp Fluorescent Light Assembly

- Switchable 2 or 4 tube fluorescent light fixture allows user to select light intensity according to the task
- Uses energy saving T5 lamps and electronic ballasts
- Comes complete with (4) 32 watt lamps and acrylic diffuser
- Fixture tilts up or down 10°
- Includes 9' power cord



Arlink 7000

	30"	36"	42"	48"	60"	72"
4 BULB T5 FLUORESCENT 19" MICRO BRACKET	N/A	7Z2015L	N/A	7Z2014L	7Z2016L	7Z2017L
4 BULB T5 FLUORESCENT 26" MICRO BRACKET	N/A	7Z2015XL	N/A	7Z2014XL	7Z2016XL	7Z2017XL

Arlink 8000

	36"	48"	60"	72"
4 BULB T5 FLUORESCENT 19" MACRO BRACKET	4375L	4475L	4675L	4775L
4 BULB T5 FLUORESCENT 26" MACRO BRACKET	4375XL	4475XL	4675XL	4775XL

Task Light Bracket

- Sturdy welded steel bracket mounts in micro slot with 1/2" diameter hole for task light

COLUMN MOUNTING BRACKET 9"	8130
COLUMN MOUNTING BRACKET 15"	8132

ARLINK 7000 AND 800 COMPUTER RELATED ACCESSORIES

CPU Holder

- Allows CPU to be mounted under the worksurface, off the floor
- Mounts to worksurface support beams



CPU Holder Arlink 7000

30" D W/SFC	36" D W/SFC
7L7000	7L7001

Arlink 8000

8440

Adjustable CPU Holder

- Adjustable pullout CPU holder has 360° rotation
- Accommodates CPU width range of 2"-8 1/2" and CPU height range of 11" - 22"
- Mounts to worksurface support beams



Adjustable CPU Holder Arlink 7000

30" D W/SFC	36" D W/SFC
7L7004	7L7005

Arlink 8000

8424

Articulating Keyboard Tray

- Tilttable keyboard holder allows computer keyboard to be stored under worksurface when not in use
- Includes swivel pull-out mouse pad which can be attached to either right or left side



Articulating Keyboard Tray Arlink 7000

30" D W/SFC	36" D W/SFC
7Z1011-30	7Z1011-36

Arlink 8000

8451

Pull Out Keyboard Tray

- Pull out keyboard holder is available in 2 sizes; 20" x 14" and 27" x 14" which will accommodate a mouse in addition to the keyboard
- Mounts to underside of worksurface



Pull Out Keyboard Tray

PART NO.	L X W
8649	20" x 14"
8656	27" x 14"

ARLINK 7000 AND 8000 PIVOTING ACCESSORIES

Equipment Shelves

- Holds a variety of customer-supplied equipment or tools
- 75 lb. capacity



Equipment Shelves

PART NO.	DESCRIPTION
8857	12 3/8" wide x 12 3/8" deep
8839	with double articulating arm

Accessory Shelves

- For easy access to small tools, instruments, parts, etc. 21 1/4" wide x 7 3/8" deep
- 75 lb. capacity
- Ribbed mat optional



Accessory Shelves

PART NO.	DESCRIPTION
8887	accessory shelf
8765	with double articulating arm
8759	ribbed rubber mat

Document Holders

- For displaying papers, plans, etc. Includes lip for pencils, pens, etc.



Document Holders

PART NO.	DESCRIPTION
8666	11 7/8" wide x 13 3/4" high
8776	with double articulating arm

Large Document Holders

- For displaying large documents, and open binders and books
- Includes lip for pencils, pens, etc.



Large Document Holders

PART NO.	DESCRIPTION
8670	23 5/8" wide x 13 3/4" high
8786	with double articulating arm

ARLINK 7000 AND 8000 ELECTRICAL ACCESSORIES

Horizontal Power Beams

- All power beams include lighted on/off switch, breaker and 7 ½' power cord
- 15 amp beams available in single- and double-sided configurations
- Mounts in micro slots, adjusts vertically in 1" increments



	24"	30"	36"	42"	48"	60"	72"
SINGLE-SIDED - 15 AMP	4290	4590	4390	4190	4490	4690	4790
SINGLE-SIDED - 15 AMP-W/USB	4291	4591	4391	4191	4491	4691	4791
SINGLE-SIDED - 15 AMP-W/GFCI	4292	4592	4392	4192	4492	4692	4792
SINGLE-SIDED - 20 AMP	4293	4593	4393	4193	4493	4693	4793
SINGLE-SIDED - 20 AMP-W/USB	4294	4594	4394	4194	4494	4694	4794
SINGLE-SIDED - 20 AMP-W/GFCI	4295	4595	4395	4195	4495	4695	4795
DOUBLE-SIDED - 15 AMP	4296	4596	4396	4196	4496	4696	4796
Outlets per side	4	6	8	8	10	10	10

Vertical Power Strips

- Available in 15 amp or 20 amp, and GFCI
- Lighted on/off switch, 6' cord with grounded plug and circuit breaker included
- Painted black
- Mounts vertically to front and back of micro slots, adjusts vertically in 1" increments
- Bracket and hardware supplied



Vertical Power Strips

	VSI-1	VSI-8
15 AMP WITH 6 OUTLETS	7Z1062	8942
20 AMP WITH 6 OUTLETS	7Z1063	8943
15 AMP GFCI WITH 6 OUTLETS	7Z1064	8947
20 AMP GFCI WITH 6 OUTLETS	7Z1065	8948

ARLINK 7000, 8000, AND VSI PANELS

Solid Privacy Panels

- Steel modesty panel acts as a privacy screen between double-sided assemblies (or single-sided where required)
- Steel panels can be used as fill-in panel or magnet panel to hold instructions or drawings
- Available in 12”H, 18”H, and 30”H



	24"	30"	36"	42"	48"	60"	72"
SOLID PRIVACY PANEL (12”H)	8820	8891	8803	8810	8804	8805	8727
SOLID PRIVACY PANEL (18”H)	8764	8142	8126	8128	8123	8465	8529
SOLID PRIVACY PANEL (30”H)	8777	8364	8356	8375	8357	8358	N/A

Pegboard Panels

- Sturdy painted steel pegboard panel, ideal for hanging tools, etc. 18” high
- Mounts in micro slots, adjusts vertically in 1” increments
- Available in 12”H, 18”H, and 30”H

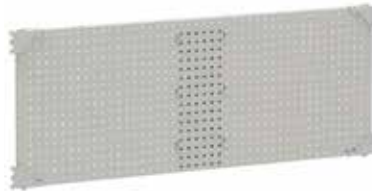

	24"	30"	36"	42"	48"	60"	72"
PEGBOARD PANEL (18”H)	8332	8333	8334	8306	8335	8336	8337
PEGBOARD PANEL (30”H)	8087	8088	8089	8083	8090	8091	N/A

Louvered Panels

- Sturdy painted steel louvered panel, holds hanging plastic bin boxes, tool or supply holders
- Mounts in micro slots, adjusts vertically in 1” increments
- Available in 18”H and 30”H



	24"	30"	36"	42"	48"	60"	72"
LOUVERED PANEL (18”H)	8441	8442	8443	8433	8444	8445	8447
LOUVERED PANEL (30”H)	8811	8598	8599	8616	8999	8654	N/A

Reversible Markerboard/Tackboards

- Two-sided reversible board
- Features white magnetic markerboard on 1 side and gray fabric tackboard on the other
- Also functions as privacy panel and sound dampener
- 30” high
- Mounts in micro slots, adjusts vertically in 1” increments



	24"	30"	36"	42"	48"	60"
MARKER BOARD/TACKBOARD 30”H	8767	8771	8772	8797	8773	8774

Panel Joiner Kit

- Panel joiner kit enables building combo panels without then need for split bay upright
- 12” AND 18” Pegboard, louvered and solid privacy panels can be combined to span 48”, 60” and 72” spaces
- Panel joiner kit cannot be used with markerboard/tackboards



12”H	18”H
8329-12	8329-18

ARLINK 7000, 8000 AND VSI WORKSTATION STORAGE AND TOOL ACCESSORIES

Overhead Cabinets

- Steel cabinet with retractable locking door
- Includes mounting brackets, lock and 2 keys
- Keyed-alike or master lock systems are available
- Mounts in micro slots, adjusts vertically in 1" increments



	24"	30"	36"	42"	48"	60"	72"
OVERHEAD CABINETS	8921	8297	8956	8310	8955	8650	8760

Heavy-Duty Parts Bin Rails

- Heavy duty parts bin rail holds heavier items such as hardware, fittings, etc. and is easily adjustable for ergonomic access
- It can be mounted parallel to the worksurface or at a 15° angle
- Mounts in micro slots, adjusts vertically in 1" increments



	24"	30"	36"	42"	48"	60"	72"
HEAVY DUTY - TILTABLE 2"	8217	8223	8225	8222	8226	8475	8546
HEAVY DUTY - TILTABLE 4"	8258	8259	8261	8264	8260	8499	8717

Utility Bins

- Full length steel bin holds tools, bottles, wipes, reeled solder dispenser, etc.
- Front edge can be used as a parts bin rail
- Mounts in micro slots, adjusts vertically in 1" increments



	24"	30"	36"	42"	48"	60"	72"
UTILITY BINS	8248	8299	8247	8207	8246	8446	8578

ARLINK 7000 AND 8000 WORKSTATION STORAGE AND TOOL ACCESSORIES

Tool and Accessory Holders

- Tool and accessory holders add convenience to the workplace
- They hang on parts bin rail or utility bin and can be positioned for easy reach

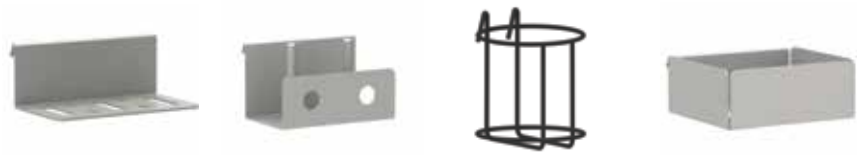

TOOL HOLDER	8277
SOLDER SPOOL HOLDER	8276
BOTTLE HOLDER	8281
KIM WIPE HOLDER	8275

Airgun Holder

- Mounts to work- surface support beam
- 1 1/2" x 1 1/2" with 1" diameter hole



AIRGUN HOLDER	4863
---------------	------

Wire Holder Assemblies

- Assembly includes support brackets (pair) and wire holder – 3/4" tube with threaded inserts
- Mounts in micro slots, adjusts vertically in 1" increments



	24"	30"	36"	48"	60"	72"
WIRE HOLDER ASSEMBLIES	8926	8886	8928	8929	8685	8785
WIRE GUIDE	8954	8301	8274	8273	8471	8583

Wire Guides

- Chrome plated bar with several holes, guides wire on the job without tangling or de-railing
- Mounts in micro slots, adjusts vertically in 1" increments

Label/Roll Holders

- Includes 1" diameter rod and brackets
- Rod is unpainted galvanized steel; brackets are painted to match frame
- 100 lb. weight capacity
- Interior mount available for dispensing labels and other smaller rolls
- Extended mount available for dispensing paper, bubble rolls, etc.



	24"	30"	36"	42"	48"	60"	72"
LABEL/ ROLL HOLDER (INTERIOR MOUNT)	4266	4566	4366	4166	4466	4666	4766
LABEL/ ROLL HOLDER (EXTENDED MOUNT)	4267	4567	4367	4167	4467	4667	4767

Tool Glide Track and Trolley Assemblies

- Smooth-moving glide keeps electric and pneumatic tools properly positioned
- If used in conjunction with fluorescent light assembly, glide track mounts on brackets for fluorescent lights



	24"	30"	36"	42"	48"	60"	72"
TOOL GLIDETRACK AND TOLLEY ASSEMBLIES	N/A	9958	9975	N/A	9976	9633	9728
ADDITIONAL TOOL TROLLEY	8184						

Data Beams

- Modular data beams feature 2 duplex-style outlets with 8 ports that accept modular snap-in/snap-out jacks or connectors for data, video, or audio connectivity
- Beams come with outlets, but jacks/connectors must be purchased separately
- On-site wiring for ports is responsibility of customer
- Mounts in micro slots, adjusts vertically in 1" increments
- Contact Lista for additional specifying assistance



DATA BEAMS	24"	30"	36"	42"	48"	60"	72"
SINGLE-SIDED	4288	4588	4388	4188	4488	4688	4788
DOUBLE-SIDED	4289	4589	4389	4189	4489	4689	4789

Air Beams

Air beam is supplied with:

- (1) 1/4" NPT female inlet on top
- (2) 1/4" NPT female outlets on front (single-sided) and (2) 1/4" NPT female outlets per side (double-sided) for 24" and 30" beams
- (3) 1/4" NPT female outlets on front (single-sided) and (3) 1/4" NPT female outlets per side (double-sided) for 36", 48", 60" and 72" beams
- (2) end mounted jumpers
- Mounts in micro slots, adjusts vertically in 1" increments



AIR BEAMS	24"	30"	36"	42"	48"	60"	72"
SINGLE-SIDED	8913	8879	8949	8846	8950	8951	8750
DOUBLE-SIDED	8914	8853	8977	8852	8978	8660	8751

Cable Trays

- Tray neatly gathers bundles of loose horizontal wires and provides random access for cable routing along its length
- Painted black
- Mounts in micro slots, adjusts vertically in 1" increments



CABLE TRAYS	24"	30"	36"	42"	48"	60"	72"
CABLE TRAYS	N/A	8302	8389	N/A	8390	8498	8597
CABLE CLIP	8391						

Air Supply Bracket

- Supplied with (1) 1/4" NPT female outlet
- Mounts under worksurface to worksurface support beam
- Single outlet



Air Supply Bracket

PART NO.
4866

Wrist Strap and Ground Block

- Mounts under worksurface to worksurface or support beams
- Dual receptacles for 2 wrist straps



Wrist Strap and Ground Block

PART NO.	DESCRIPTION
SC12	ground block
SC15	wrist strap with 6' coil cord*

* with 1 megohm resistor

Ground Kits

- Kit is supplied with all static dissipative worksurfaces or shelves
- Includes attaching hardware

Ground Kits

PART NO.	DESCRIPTION
SC10	worksurface kit with 8' cord*
SC30	shelf kit with 6' cord**

* with 1 megohm resistor

** without 1 megohm resistor

Common Point Ground Block

- Two connection sides – one side connects to a 1 megohm resistor, the other side bypasses the resistor and connects directly to ground
- Includes 8' cord



Common Point Ground Block

PART NO.
SC14

FLAT PANEL MONITOR ARMS (ARLINK & NEXUS)

Basic Flat Panel Monitor Arm: Horizontal Articulation; Column Mount

- Articulates horizontally
- Factory pre-tensioned articulated head
- Factory pre-tensioned joints
- Vesa 75/100 interface plate
- Supports up to 18 lbs. (8kg)
- Maximum reach 16" (407mm)
- Mounts to Arlink 8000 and Nexus uprights



Basic Dual Flat Panel Monitor Arm

ARLINK 8000 PART NO.	NEXUS PART NO.	DESCRIPTION	WEIGHT
4037	NX4037	Basic Flat Panel Monitor Arm, Column Mount	6 lbs.

Basic Dual Flat Panel Monitor Arm: Horizontal Articulation; Column Mount

- Articulates horizontally
- Factory pre-tensioned articulated head
- Factory pre-tensioned joints
- Vesa 75/100 interface plate
- Supports up to 18 lbs. (8kg) per arm
- Maximum reach 16" (407mm)
- Mounts to Arlink 8000 and Nexus uprights



Basic Dual Flat Panel Monitor Arm

ARLINK 8000 PART NO.	NEXUS PART NO.	DESCRIPTION	WEIGHT
4045	NX4045	Basic Dual Flat Panel Monitor Arm, Column Mount	12 lbs.

Basic Flat Panel Monitor Arm: Horizontal Articulation; Post Mount

- Articulates horizontally
- Factory pre-tensioned articulated head
- Factory pre-tensioned joints
- Vesa 75/100 interface plate
- Supports up to 18 lbs. (8kg)
- Maximum reach 16" (407mm)
- Solid 1" diameter 13" high aluminum post
- Mounts through worksurface, hole diameter 1/2"



Basic Flat Panel Monitor Arm

ARLINK 8000 PART NO.	NEXUS PART NO.	DESCRIPTION	WEIGHT
4054	NX4054	Basic Flat Panel Monitor Arm, Post Mount	6 lbs.

FLAT PANEL MONITOR ARMS (ARLINK & NEXUS) (CONT)

Gas Assist Tablet Arms

- Mount in microslots
- Dual cylinders with adjustable brake
- Provides easy fluid movement with fingertip control
- Supports 2–5 lbs.
- 16.7" maximum reach



Gas Assist Tablet Arms

	ARLINK 8000 COLUMN MOUNT	ARLINK 8000 POST MOUNT	NEXUS COLUMN MOUNT	NEXUS POST MOUNT
iPad 2,3,4	4047	4081	NX4047	NX4081
iPad Air	4057	4082	NX4057	NX4082
iPad Mini	4058	4083	NX4058	NX4083

Basic Dual Flat Panel Monitor Arm: Horizontal Articulation; Post Mount

- Articulates horizontally
- Factory pre-tensioned articulated head
- Factory pre-tensioned joints
- Vesa 75/100 interface plate
- Supports up to 18 lbs. (8kg) per arm
- Maximum reach 16" (407mm)
- Solid 1" diameter 13" high aluminum post
- Mounts through worksurface, hole diameter ½"



Basic Dual Flat Panel Monitor Arm

ARLINK 8000 PART NO.	NEXUS PART NO.	DESCRIPTION	WEIGHT
4060	NX4060	Basic Dual Flat Panel Monitor Arm, Post Mount	18 lbs.

Flat Panel Monitor Arms

- For attaching flat panel monitor to upright
- 17 ½ lb. capacity
- Mounts in macro slots, adjusts vertically in 3" increments *Includes mounting bracket
- Swings left and right, and has 2 articulating points
- Option to include a 9" extender which allows positioning of monitor screen away from adjacent accessories



Flat Panel Monitor Arms

ARLINK 8000 PART NO.	NEXUS PART NO.	DESCRIPTION
8415	NX8415	attaches to column
8628	NXA/FPMA	includes 9" bracket extender

FLAT PANEL MONITOR ARMS (ARLINK & NEXUS) (CONT)

Full Function Flat Panel Monitor Arm: Vertical and Horizontal Articulation; Column Mount

- 6 lockable positions for arm and Vesa plate
- Articulates horizontally and vertically
- Factory pre-tensioned articulated head
- Vesa 75/100 interface plate
- Supports up to 26 lbs. (12kg)
- 12" height adjustment
- Maximum reach of 15.9" (404mm)
- Mounts to Arlink 8000 and Nexus uprights



Full Function Flat Panel Monitor Arm

ARLINK 8000 PART NO.	NEXUS PART NO.	DESCRIPTION	WEIGHT
4036	NX4036	Full Function Flat Panel Monitor Arm, Column Mount	8 lbs.

Full Function Dual Flat Panel Monitor Arm: Vertical and Horizontal Articulation; Column Mount

- 6 lockable positions for arm and Vesa plate
- Articulates horizontally and vertically
- Factory pre-tensioned articulated head
- Vesa 75/100 interface plate
- Supports up to 26 lbs. (12kg) per arm
- 12" height adjustment
- Maximum reach of 15.9" (404mm)
- Mounts to Arlink 8000 and Nexus uprights



Full Function Flat Panel Monitor Arm

ARLINK 8000 PART NO.	NEXUS PART NO.	DESCRIPTION	WEIGHT
4044	NX4044	Full Function Dual Flat Panel Monitor Arm, Column Mount	16 lbs.

Full Function Flat Panel Monitor Arm: Vertical and Horizontal Articulation; Post Mount

- 6 lockable positions for arm and Vesa plate
- Articulates horizontally and vertically
- Factory pre-tensioned articulated head
- Vesa 75/100 interface plate
- Supports up to 26 lbs. (12kg)
- 12" height adjustment
- Maximum reach of 15.9" (404mm)
- Solid 1.5" diameter 15.75" high aluminum post
- Mounts through worksurface, hole diameter 1/2"



Full Function Flat Panel Monitor Arm

ARLINK 8000 PART NO.	NEXUS PART NO.	DESCRIPTION	WEIGHT
4053	NX4053	Full Function Flat Panel Monitor Arm, Post Mount	8 lbs.

Keyboard Holder for Flat Panel Monitor Arms

- 22" Monitor mounted keyboard holder
- Mounts between monitor and VESA plate
- Compatible with all Lista monitor arms



Keyboard Holder for Flat Panel Monitor Arm

ARLINK 8000 PART NO.	NEXUS PART NO.	DESCRIPTION
4067	NX4067	Keyboard Holder-Flat Panel Arm

FLAT PANEL MONITOR ARMS (ARLINK & NEXUS) (CONT)

Full Function Dual Flat Panel Monitor Arm: Vertical and Horizontal Articulation; Post Mount

- 6 lockable positions for arm and Vesa plate
- Articulates horizontally and vertically
- Factory pre-tensioned articulated head
- Vesa 75/100 interface plate
- Supports up to 26 lbs. (12kg) per arm
- 12" height adjustment
- Maximum reach of 15.9" (404mm)
- Solid 1.5" diameter 15.75" high aluminum post
- Mounts through worksurface, hole diameter 1/2"

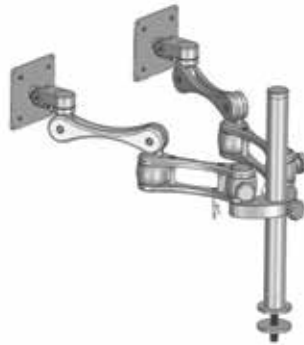

Full Function Dual Flat Panel Monitor Arm

ARLINK 8000 PART NO.	NEXUS PART NO.	DESCRIPTION	WEIGHT
4059	NX4059	Full Function Dual Flat Panel Monitorpr Arm, Post Mount	16 lbs.

FLAT PANEL MONITOR ARM ADDITIONAL OPTIONS

Full Function Extended Flat Panel Monitor Arm: Vertical and Horizontal Articulation; Column Mount, with 9 1/4" Extension

- 6 lockable positions for arm and Vesa plate
- Articulates horizontally and vertically
- Factory pre-tensioned articulated head
- Vesa 75/100 interface plate
- Supports up to 22 lbs. (10kg)
- 12" height adjustment
- Maximum reach of 25" (635mm)
- Mounts to Arlink 8000 and Nexus uprights



Full Function Extended Flat Panel Monitor Arm

ARLINK 8000 PART NO.	NEXUS PART NO.	DESCRIPTION	WEIGHT
4063	NX4063	Full Function Extended Flat Panel Monitor Arm, Col. Mount	10 lbs.

Mounting Rails (1 Knuckle) and Mounting Knuckles for Rails

- Allows multiple monitors on multiple levels
- Clamp mount knuckle can be positioned to any horizontal position.
- 5" knuckles allow tilt and angle adjustment
- Vesa 75/100 interface plate
- Rail locks into Arlink 8000 and Nexus micro slots
- Each rail includes 1 monitor mounting knuckle. Specify additional knuckles as required. Monitor size will dictate number of monitors that can be accommodated per rail.
- Some assembly required
- Mounts to Arlink 8000 and Nexus uprights

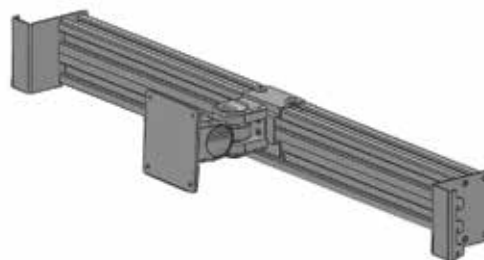

Mounting Rails (1 Knuckle)

ARLINK 8000 PART NO.	NEXUS PART NO.	DESCRIPTION	WEIGHT
4069	NX4069	24" Rail with 1 Knuckle	12 lbs.
4070	NX4070	30" Rail with 1 Knuckle	12 lbs.
4071	NX4071	36" Rail with 1 Knuckle	13 lbs.
4076	NX4076	42" Rail with 1 Knuckle	13 lbs.
4072	NX4072	48" Rail with 1 Knuckle	15 lbs.
4073	NX4073	60" Rail with 1 Knuckle	17 lbs.
4074	NX4074	72" Rail with 1 Knuckle	19 lbs.
4075	NX4075	Monitor Knuckle for Rail	2 lbs.

ALIGN® ADJUSTABLE HEIGHT WORKSTATIONS

Align® Adjustable Height Workstations bring the user an unsurpassed level of ergonomic comfort, flexible functionality and enhanced productivity.

With an adjustable height ranging from 27" to 42" (not including worksurface), this workspace solution is designed with the operator in mind. It reduces fatigue, stress and potential injury. The workstation is ideally suited for repairing, testing, and assembling mechanical and electronic products and components.

Innovative features include:

- Proven, tested technology with thousands of units in use in the field
- Universal platform, which can be adjusted via motor, hand crank or manually adjusted without a lift mechanism (slide leg base)
- Center- and rear-justified options available
- Precision drive system for maintenance-free reliability
- Built-in cable/hose management duct and modesty panel
- Available for 30", 48", 60", 72" and 90" length worksurfaces, and 24", 30", 36" and 48" depth worksurfaces
- Load capacity 1000 lbs. dynamic for motorized base and 500 lbs. dynamic for hand crank base



ALIGN® ADJUSTABLE HEIGHT WORKSTATIONS

Model ALE/R workstations include an Align rear-justified motorized base. Model ALC/R workstations include an Align rear-justified crank base.

See page 227 for hanging cabinet descriptions.

How to order an Easy-Order Align Adjustable Height Workstation

1. Select Easy-Order workstation configuration.

2. Select worksurface style.

See pages 224–225 for worksurface descriptions.

PLB = Plastic laminate

BTB = Butcher block

SDB = Static dissipative

(includes ground cord and hardware)

All worksurfaces have a bullnose front edge and are 30" deep.

3. Select worksurface size.

6030 = 60" long x 30" deep

7230 = 72" long x 30" deep

4. Select paint color.

Add 2-letter paint code shown in color chart on inside back cover.

5. Select lock type for models with hanging cabinet.

RG = individual

KA = keyed-alike

MA = master

EXAMPLE: to order an ALE/R5201 workstation with a 72" long plastic laminate worksurface and shelf and Classic Blue paint, with an individual lock for the hanging cabinet, the part number would be **ALE/R5201-PLB7230CB**, with a **WBHC450-2-RG** hanging cabinet.

Workstations with Worksurface

To add Easy-Order Nexus System configuration to workstations with worksurface shown below, see pages 232-233.

Workstations with Adjustable Riser Shelf

Includes:

- Worksurface back stop
- Adjustable riser shelf with back stop

Workstations with Instrument Riser Shelf

Includes:

- (2) 16" instrument riser supports (1 with power)
- 12" deep instrument riser shelf
- Worksurface and shelf back stops



PART NO.	DESCRIPTION
ALE/R5000- ■ ■ 	motorized
ALC/R5000- ■ ■ 	hand crank



PART NO.	DESCRIPTION
ALE/R5001- ■ ■ 	motorized
ALC/R5001- ■ ■ 	hand crank



PART NO.	DESCRIPTION
ALE/R5002- ■ ■ 	motorized
ALC/R5002- ■ ■ 	hand crank



PART NO.	INCLUDES
ALE/R5100- ■ ■ 	WBHC150-1-hanging cabinet
ALC/R5100- ■ ■ 	WBHC150-1-hanging cabinet



PART NO.	INCLUDES
ALE/R5101- ■ ■ 	WBHC150-1-hanging cabinet
ALC/R5101- ■ ■ 	WBHC150-1-hanging cabinet

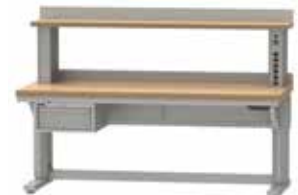

PART NO.	INCLUDES
ALE/R5102- ■ ■ 	WBHC150-1-hanging cabinet
ALC/R5102- ■ ■ 	WBHC150-1-hanging cabinet



PART NO.	INCLUDES
ALE/R5200- ■ ■ 	WBHC450-2-hanging cabinet
ALC/R5200- ■ ■ 	WBHC450-2-hanging cabinet



PART NO.	INCLUDES
ALE/R5201- ■ ■ 	WBHC450-2-hanging cabinet
ALC/R5201- ■ ■ 	WBHC450-2-hanging cabinet



PART NO.	INCLUDES
ALE/R5202- ■ ■ 	WBHC450-2-hanging cabinet
ALC/R5202- ■ ■ 	WBHC450-2-hanging cabinet

ALIGN WORKBENCH WORKSURFACES

Lista worksurfaces are all easy to maintain, rugged, and durable.

Worksurfaces come in 48", 60", 72", 84", 90" and 96" lengths, and are 24", 30" or 36" deep, depending on worksurface. Other sizes are available, and certain worksurfaces are available with a bullnose front edge.

Butcher Block Worksurface-Sq Edge (BB), Bullnose (BN)

- Satin finish 1 3/4" thick hardwood
- Available in standard square edge or bullnose front edge



Butcher Block

PART NO.	LENGTH
24" deep	
BTOP-4824	48"
BTOP-6024	60"
BTOP-7224	72"
BTOP-8424	84"
BTOP-9024	90"
BTOP-9624	96"

30" deep

BTOP-48	48"
BTOP-60	60"
BTOP-72	72"
BTOP-84	84"
BTOP-90	90"
BTOP-96	96"

36" deep

BTOP-4836	48"
BTOP-6036	60"
BTOP-7236	72"
BTOP-8436	84"
BTOP-9036	90"
BTOP-9636	96"

Lista Top (LT)

- 1 3/4" thick worksurface with wood core and 3/8" sanded, oil resistant pressed wood, top and bottom



Lista Top (LT)

PART NO.	LENGTH
30" deep	
LTOP-48	48"
LTOP-60	60"
LTOP-72	72"
LTOP-84*	84"
LTOP-90*	90"
LTOP-96*	96"

36" deep

LTOP-4836	48"
LTOP-6036	60"
LTOP-7236	72"
LTOP-8436*	84"
LTOP-9036*	90"
LTOP-9636*	96"

*requires additional support (third leg or hat section stiffener)

Static Dissipative Plastic Laminate

Particle board core with plastic laminated top and sides, 1 9/16" thick. Grounding bolt and 10' grounding cord with a 1 megohm resistor included (installation required). Standard color is dove gray but other colors available on request. Available in standard square edge or bullnose front edge (shown above). To order a bullnose edge, add "BN" to end of part number.

Worksurfaces display electrical properties within static dissipative boundaries of 10⁶-10⁹ ohms over a wide range of relative humidities (ranging from 60% RH to as low as 10% RH) to meet ESD specifications. Meets EOS/ESD S4.1 specifications. For detailed specifications, please contact Lista.



Static Dissipative Plastic Laminate

PART NO.	LENGTH
24" deep	
SDTOP-4824	48"
SDTOP-6024	60"
SDTOP-7224	72"
SDTOP-8424*	84"
SDTOP-9024*	90"
SDTOP-9624*	96"

30" deep

SDTOP-48	48"
SDTOP-60	60"
SDTOP-72	72"
SDTOP-84*	84"
SDTOP-90*	90"
SDTOP-96*	96"

36" deep

SDTOP-4836	48"
SDTOP-6036	60"
SDTOP-7236	72"
SDTOP-8436*	84"
SDTOP-9036*	90"
SDTOP-9636*	96"

*requires additional support (third leg or hat section stiffener)

ALIGN WORKBENCH WORKSURFACES

Galvanized Steel Over Wood

Lista Top with additional heavy-gauge galvanized steel cover that is fitted over top and sides of Lista Top, 1 13/16" thick.



Galvanized Steel Over Wood

PART NO.	LENGTH
30" deep	
LSTOP-48	48"
LSTOP-60	60"
LSTOP-72	72"
LSTOP-84	84"
LSTOP-90	90"
LSTOP-96	96"

36" deep

LSTOP-4836	48"
LSTOP-6036	60"
LSTOP-7236	72"
LSTOP-8436	84"
LSTOP-9036	90"
LSTOP-9636	96"

Stainless Steel Over Wood

Worksurface is constructed of durable, heavy gauge stainless steel, fitted over top and sides of particle board, 1 13/16" thick.



Stainless Steel Over Wood

PART NO.	LENGTH
30" deep	
LSSTOP-48	48"
LSSTOP-60	60"
LSSTOP-72	72"
LSSTOP-84	84"
LSSTOP-90	90"
LSSTOP-96	96"

36" deep

LSSTOP-48X36	48"
LSSTOP-60X36	60"
LSSTOP-72X36	72"
LSSTOP-84X36	84"
LSSTOP-90X36	90"
LSSTOP-96X36	96"

Plastic Laminate

Particle board core with plastic laminated top and sides. 1 9/16" thick. Dove gray is standard but other colors are available on request. Available in standard square edge or bullnose front edge. To order a bullnose edge, add "BN" to the end of the part number.



Plastic Laminate

PART NO.	LENGTH
24" deep	
PTOP-4824	48"
PTOP-6024	60"
PTOP-7224	72"
PTOP-8424*	84"
PTOP-9024*	90"
PTOP-9624*	96"

30" deep

PTOP-48	48"
PTOP-60	60"
PTOP-72	72"
PTOP-84*	84"
PTOP-90*	90"
PTOP-96*	96"

36" deep

PTOP-4836	48"
PTOP-6036	60"
PTOP-7236	72"
PTOP-8436*	84"
PTOP-9036*	90"
PTOP-9636*	96"

*requires additional support (third leg or hat section stiffener)

ALIGN® ADJUSTABLE HEIGHT WORKSTATION OPERATOR-ADJUSTABLE BASES

Motorized Bases

- Features a low-EMS, low-voltage dual actuator controller for synchronized leg movement and stress-free operation
- Three height positions can be preset with the programmable switch
- Static and dynamic load capacity is 1,000 lbs.
- Height range (floor to top of base, not including worksurface) is 27"-42"
- Worksurface not included – see pages 224–225 for worksurface choices
- Some assembly required



Motorized Base rear-justified with optional casters

Motorized Bases, Rear-Justified

PART NO.	BASE WIDTH	WORKSURFACE LENGTH (MIN.)
24" deep		
ALE/R3024	29"	30"
ALE/R4824	47"	48"
ALE/R6024	59"	60"
ALE/R7224	71"	72"
ALE/R9024	89"	90"
30" deep		
ALE/R3030	29"	30"
ALE/R4830	47"	48"
ALE/R6030	59"	60"
ALE/R7230	71"	72"
ALE/R9030	89"	90"
36" deep		
ALE/R3036	29"	30"
ALE/R4836	47"	48"
ALE/R6036	59"	60"
ALE/R7236	71"	72"
ALE/R9036	89"	90"

Motorized Bases, Center-Justified

PART NO.	BASE WIDTH	WORKSURFACE LENGTH (MIN.)
30" deep		
ALE/C3030	29"	30"
ALE/C4830	47"	48"
ALE/C6030	59"	60"
ALE/C7230	71"	72"
ALE/C9030	89"	90"
36" deep		
ALE/C3036	29"	30"
ALE/C4836	47"	48"
ALE/C6036	59"	60"
ALE/C7236	71"	72"
ALE/C9036	89"	90"
48" deep		
ALE/C6048	59"	60"
ALE/C7248	71"	72"
ALE/C9048	89"	90"

Hand Crank Bases

- Hand crank static load capacity is 1,000 lbs., dynamic load capacity is 500 lbs.
- Height range (floor to top of base, not including worksurface) is 27"-42"
- Worksurface not included – see pages 224–225 for worksurface choices
- Some assembly required



Hand crank Base center-justified

Hand Crank Bases, Rear-Justified

PART NO.	BASE WIDTH	WORKSURFACE LENGTH (MIN.)
24" deep		
ALC/R3024	29"	30"
ALC/R4824	47"	48"
ALC/R6024	59"	60"
ALC/R7224	71"	72"
ALC/R9024	89"	90"
30" deep		
ALC/R3030	29"	30"
ALC/R4830	47"	48"
ALC/R6030	59"	60"
ALC/R7230	71"	72"
ALC/R9030	89"	90"
36" deep		
ALC/R3036	29"	30"
ALC/R4836	47"	48"
ALC/R6036	59"	60"
ALC/R7236	71"	72"
ALC/R9036	89"	90"

Hand Crank Bases, Center-Justified

PART NO.	BASE WIDTH	WORKSURFACE LENGTH (MIN.)
30" deep		
ALC/C3030	29"	30"
ALC/C4830	47"	48"
ALC/C6030	59"	60"
ALC/C7230	71"	72"
ALC/C9030	89"	90"
36" deep		
ALC/C3036	29"	30"
ALC/C4836	47"	48"
ALC/C6036	59"	60"
ALC/C7236	71"	72"
ALC/C9036	89"	90"
48" deep		
ALC/C6048	59"	60"
ALC/C7248	71"	72"
ALC/C9048	89"	90"

ALIGN® ADJUSTABLE HEIGHT WORKSTATION ACCESSORIES

Casters

- Casters can be added to any adjustable height base to allow mobility
- Caster is 5" diameter, increases overall height 6". 325 lb. capacity per caster



Casters

PART NO.	DESCRIPTION
AL/CAST5X1	5" caster set, (2) swivel, (2) swivel-with-wheel-lock
CAST5X1S-NB	(1) swivel 5" caster
CAST5X1S-WB	(1) swivel-with-wheel-lock 5" caster

Offset Caster Assembly

- Offset caster assemblies do not increase the overall height range of the base
- Welded frame replaces standard feet
- Includes pair of offset frames with (2) 5" swivel casters and (2) 5" swivel-with-wheel-lock casters
- Rear casters extend 4" beyond back of worksurface
- Painted to match base
- For motorized and hand crank bases only



Offset Caster Assembly

PART NO.	DESCRIPTION
AL/CAST5X1-OF	pair of frames

Workstation Hanging Cabinets

- 16 3/4" (426mm) wide x 19 1/4" (491mm) deep
- Cabinet is suspended from the worksurface
- 50 lb. (22.5kg) weight capacity per drawer
- Usable inside dimensions: 13 1/4" (338.5mm) wide x 16 15/16" (430mm) deep
- Drawers do not accept Lista partitions and dividers
- Not available for center-justified or 24" deep rear-justified Align workstations. Cabinet can not be positioned at same end of bench as keypad or hand crank.
- Comes with individual lock and 2 keys



Figure 1

Figure 2

Figure 3

Figure 4



Figure 5

Figure 6

Figure 7

Figure 8



Figure 9

Figure 10

Figure 11

Figure 12

How to order a hanging cabinet

1. Select cabinet.
2. Select lock type.*

NL = none

KA = keyed-alike

RG = individual

MA = master

KP = keypad

3. Select paint color.
For color chart, see inside back cover.

*units ordered without lock can not have lock installed at a later date

FOR USE WITH THESE BENCHES

FIGURE	ALIGN	INDUSTRIAL & TECHNICAL	CABINET HEIGHT	DRAWER 1	DRAWER 2	DRAWER 3	DRAWER 4
1	WBHC075-1-AL	WBHC075-1-WB	5.20"	2-3/4"			
2	WBHC150-1-AL	WBHC150-1-WB	8.15"	5-3/4"			
3	WBHC150-2-AL	WBHC150-2-WB	8.15"	2-3/4"	2-3/4"		
4	WBHC300-1-AL	WBHC300-1-WB	14.06"	12" File			
5	WBHC300-2-AL	WBHC300-2-WB	14.06"	5-3/4"	5-3/4"		
6	WBHC300-3-AL	WBHC300-3-WB	14.06"	2-3/4"	2-3/4"	5-3/4"	
7	WBHC300-4-AL	WBHC300-4-WB	14.06"	2-3/4"	2-3/4"	2-3/4"	2-3/4"
8	WBHC450-1FD-AL	WBHC450-1FD-WB	19.96"	5-3/4"	Door		
9	WBHC450-2-AL	WBHC450-2-WB	19.96"	5-3/4"	12" File		
10	WBHC450-3-AL	WBHC450-3-WB	19.96"	5-3/4"	5-3/4"	5-3/4"	
11	WBHC450-31-AL	WBHC450-31-WB	19.96"	2-3/4"	2-3/4"	12" File	
12	WBHC450-4-AL	WBHC450-4-WB	19.96"	2-3/4"	2-3/4"	5-3/4"	5-3/4"

DRAWER PULL OPTIONS DESCRIPTION

Hanging Cabinet Tech Drawer Pull (Chrome Color)
Hanging Cabinet Tech Drawer Pull (Brushed Silver)
Hanging Cabinet Tech Drawer Pull (Gloss Black)

ALIGN & INDUSTRIAL UPGRADE

HNDL-NSNW/CHRM
HNDL-NSNW/BRSH
HNDL-NSNW/GBLK

ALIGN® ADJUSTABLE HEIGHT WORKSTATION ACCESSORIES

Align Bottom Shelves

- Provides open storage beneath worksurface
- 16" deep
- Accepts vertical wire dividers (see below)
- 150 lb. (68kg) capacity
- For motorized and hand crank bases only

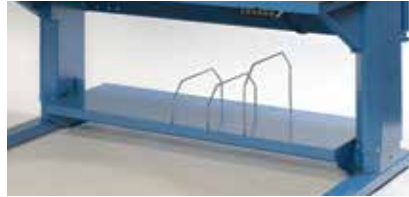

Bottom Shelves

PART NO.	LENGTH
ALBS/F-4816	48"
ALBS/F-6016	60"
ALBS/F-7216	72"
ALBS/F-9016	90"

Vertical Wire Dividers for Bottom Shelves

- 15" deep dividers are 1/4" diameter galvanized wire that fit into pre-punched holes in the 16" deep shelf
- No hardware required



Wire Dividers

PART NO.	HEIGHT
NXS/WD150-15	6"
NXS/WD250-15	10"
NXS/WD450-15	18"

CPU Holder

- Mounts to underside of worksurface
- 9 1/2" wide x 18" deep x 20" high
- Painted to match workstation



CPU Holder

PART NO.
CPU/H

Adjustable CPU Holder

- Adjustable pullout CPU holder has 360° rotation
- Accommodates CPU width range of 2"-8 1/2" and CPU height range of 11"-22"
- Mounts to worksurface support beams

Adjustable CPU

Holder
CPU/H-ADJ/SOR

Keyboard Holder

- Tilttable keyboard holder allows computer keyboard to be stored under worksurface when not in use
- Includes swivel pull-out mouse pad which can be attached to either right or left side



Keyboard Holder

PART NO.	L X W
WB/KBH	21" x 10"

Align Attached Footrest

- Ergonomic footrest attaches over Align base stringer
- Height adjustable from 3"-12 1/4" (plus height of stringer)
- Footrest platform is 15" deep x 21 3/4" wide, and adjusts from totally flat to a 25° angle
- Ribbed mat included
- Not compatible with 30" wide Align workstations



Attached Footrest

PART NO.
AL/AFR

Freestanding Footrest

- Ergonomic footrest provides support for user's feet
- Height adjustable from 3"-12 1/4"
- Footrest platform is 15" deep x 21 3/4" wide, and adjusts from totally flat to a 25° angle
- Ribbed mat included



Freestanding Footrest

WB/FFR

ALIGN® ADJUSTABLE HEIGHT WORKSTATION ACCESSORIES

Nexus Rear-Mount Frames

- For use with Align® rear-justified adjustable height bases only
- Starter frames consist of 2 upright posts, a horizontal rail, brackets and hardware
- Adder sets consist of an additional upright, a horizontal rail and a bracket
- Frames are sturdy, heavy gauge steel, and are notched front and back at 1" increments for mounting accessories
- Uprights are available in heights of 30" and 48" (height = height above top of base), and widths of 24", 30", 36", 42", 48" and 60"
- Specify color from chart on the inside back cover
- Must be inset 3" to center of upright. For wider applications see Nexus Extender Rear mount frames below



30" High* Rear-Mount Frames

PART NO.	SEC. WIDTH CENT.-TO-CENT.
Starter set	
NXF/RM2430	24"
NXF/RM3030	30"
NXF/RM3630	36"
NXF/RM4230	42"
NXF/RM4830	48"
NXF/RM6030	60"
Adder set	
NXF/RM2430A	24"
NXF/RM3030A	30"
NXF/RM3630A	36"
NXF/RM4230A	42"
NXF/RM4830A	48"
NXF/RM6030A	60"

* upright overall height is 48"

48" High* Rear-Mount Frames

PART NO.	SEC. WIDTH CENT.-TO-CENT.
Starter set	
NXF/RM2448	24"
NXF/RM3048	30"
NXF/RM3648	36"
NXF/RM4248	42"
NXF/RM4848	48"
NXF/RM6048	60"
Adder set	
NXF/RM2448A	24"
NXF/RM3048A	30"
NXF/RM3648A	36"
NXF/RM4248A	42"
NXF/RM4848A	48"
NXF/RM6048A	60"

* upright overall height is 60"

Nexus Extended Rear-Mount Frames

- For use with Align® rear-justified adjustable height bases only
- Allows use of the full width of an Align rear-justified adjustable height workstation for support of a Nexus system
- The total width of the extended rear-mount frame must equal the width of the Align workstation
- Extended rear-mount frame is the starter set; use the standard rear-mount adder for adder unit
- Not for use with Align workstations that are placed flush side-to-side
- Specify color from chart on back cover
- Extends approximately ¾" beyond end of work surface at each end



30" High* Extended Rear-Mount Frames

PART NO.	WIDTH
NXF/RM2430-EXT	24"
NXF/RM3030-EXT	30"
NXF/RM3630-EXT	36"
NXF/RM4230-EXT	42"
NXF/RM4830-EXT	48"
NXF/RM6030-EXT	60"

* upright overall height is 48"

48" High* Extended Rear-Mount Frames

PART NO.	WIDTH
NXF/RM2448-EXT	24"
NXF/RM3048-EXT	30"
NXF/RM3648-EXT	36"
NXF/RM4248-EXT	42"
NXF/RM4848-EXT	48"
NXF/RM6048-EXT	60"

* upright overall height is 60"

NEXUS SYSTEM FEATURES

Lista's Nexus System is a highly functional and flexible system of above-worksurface accessories and modular components. It has been designed to cost-effectively meet the needs of a broad variety of jobs.

The system has been ergonomically designed, delivering easy accessibility with no stretch or strain, reducing the risk of injury and increasing productivity.

Like all Lista systems, the Nexus System is modular and allows for easy reconfiguration. It can easily be adapted or expanded to meet changing needs. It can also be retrofitted to any existing workbench, whether it's from Lista or another manufacturer. Many Nexus components can be easily adjusted for specific tasks within a workshift. System width is limited only by your worksurface length.

All components are available in ESD paint for static-sensitive applications.

Nexus System accessories can also be used with our other Nexus System products.

Nexus System benefits include:

Greater productivity and efficiency:

- Extensive selection of heights and widths, allowing you to configure your workspace to fit your needs.

Reduced strain, increased ergonomic ease:

- Accessories can be chosen and positioned to best suit each user for ultimate ergonomic adaptability.
- Many accessories can tilt and pivot in a number of positions, easily adjusting to the most comfortable and useful position.

Workstations equipped to exactly suit your needs:

- The wide choice of accessories means that whatever the task, an appropriate accessory is available.

Properly illuminated work area:

- Light fixtures can be easily positioned at the desired height, depth and angle.

Maximum available worksurface:

- Articulating arms mount to Nexus uprights, leaving full surface available for task.

NOTE: Many or most Nexus System accessories are compatible with Arlink® 8000 or VSI uprights.

Overhead light fixture _____
 Tool rail _____

Reversible markerboard/
 tackboard _____

Louvered panel _____

Adjustable shelf _____

Monitor shelf _____

Horizontal power rail _____

Back stop _____

Accessory shelf _____



Lista's advanced Nexus System enables the user to customize the workspace for the greatest productivity and ergonomic comfort. Accessories can be easily added and moved to provide complete flexibility and ease of use.

PRECONFIGURED NEXUS SYSTEM COMBINATIONS

Each combination includes 1 Nexus starter frame and 1 adder frame at the height shown. Combinations designated with "SM" surface mount to a Lista or other workbench with a worksurface at least 6" longer than the Nexus frames. Combinations designated with "RM" rear mount to a Lista Align® adjustable height base only. Certain combinations are available with optional overhead lights (see charts below illustrations for availability).

How to order a Preconfigured Nexus Accessory Combination

1. Select Preconfigured Nexus Accessory.

2. ■ Select worksurface length.

60 = 60" long (combination consists of 24" wide starter frame and 30" wide adder frame)

72 = 72" long (combination consists of 30" wide starter frame and 36" wide adder frame)

3. □ Select paint color. For color chart, see inside back cover.

4. ■ Select lock type for models with overhead cabinets included.

RG = individual
KA = keyed-alike
MA = master

EXAMPLE: to order an NXC/SM4827 Nexus combination to install on a 72" long worksurface, with Bright Blue paint and keyed-alike locks for the overhead cabinets, the part number would be **NXC/SM4827-72BBKA**.

30" High Nexus Frames



Includes:

- (2) 12" deep shelves
- (1) back stop
- (1) 30" high louvered panel

PART NO. DESCRIPTION
 NXC/SM3001-■□ surface-mount



Includes:

- (2) 12" deep shelves
- (1) plastic box rail
- (1) 30" high markerboard/tackboard
- (1) vertical power strip

PART NO. DESCRIPTION
 NXC/SM3002-■□ surface-mount



Includes:

- (2) 12" deep shelves
- (1) back stop
- (1) 18" high solid privacy panel
- (1) 16" high overhead cabinet with retractable door

PART NO. DESCRIPTION
 NXC/SM3023-■□■ surface-mount



Includes:

- (2) 12" deep shelves
- (2) 15" deep shelves
- (2) back stops

PART NO. DESCRIPTION
 NXC/SM3005-■□ surface-mount



Includes:

- (2) 18" deep variable angle shelves
- (1) 12" deep shelf
- (1) 18" high louvered panel

PART NO. DESCRIPTION
 NXC/SM3006-■□ surface-mount



Includes:

- (1) 12" deep shelf
- (1) 18" high louvered panel
- (1) 16" high overhead cabinet with retractable door
- (1) horizontal power rail
- (1) back stop

PART NO. DESCRIPTION
 NXC/SM3024-■□■ surface-mount

48" High Nexus Frames

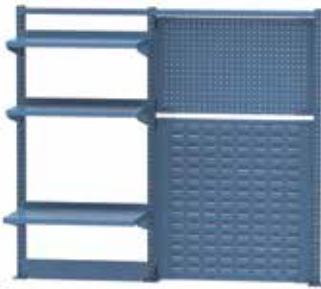

Includes:

- (2) 12" deep shelves
- (1) 15" deep shelf
- (1) back stop
- (1) 18" high pegboard panel
- (1) 30" high louvered panel

PART NO.	DESCRIPTION
NXC/SM4801- <input type="checkbox"/>	surface-mount
NXC/SM4811- <input type="checkbox"/>	surface-mount with 56" 4-bulb overhead light
NXC/RM4801- <input type="checkbox"/>	rear-mount for Align base
NXC/RM4811- <input type="checkbox"/>	rear-mount for Align base with 56" 4-bulb overhead light



Includes:

- (2) 12" deep shelves
- (1) 15" deep shelf
- (1) back stop
- (1) 30" high markerboard/tackboard
- (1) 18" high louvered panel
- (1) vertical power strip

PART NO.	DESCRIPTION
NXC/SM4802- <input type="checkbox"/>	surface-mount
NXC/SM4812- <input type="checkbox"/>	surface-mount with 56" 4-bulb overhead light
NXC/RM4802- <input type="checkbox"/>	rear-mount for Align base
NXC/RM4812- <input type="checkbox"/>	rear-mount for Align base with 56" 4-bulb overhead light



Includes:

- (2) 12" deep shelves
- (1) 18" high louvered panel
- (1) 16" high overhead cabinet with retractable door
- (1) 30" high markerboard/tackboard

PART NO.	DESCRIPTION
NXC/SM4823- <input type="checkbox"/>	surface-mount
NXC/RM4823- <input type="checkbox"/>	rear-mount for Align base



Includes:

- (2) 16" high overhead cabinets with retractable doors
- (1) 12" deep shelf
- (1) back stop
- (1) 30" high markerboard/tackboard

PART NO.	DESCRIPTION
NXC/SM4827- <input type="checkbox"/>	surface-mount
NXC/RM4827- <input type="checkbox"/>	rear-mount for Align base



Includes:

- (4) 12" deep shelves
- (2) 15" deep shelves
- (2) back stops

PART NO.	DESCRIPTION
NXC/SM4804- <input type="checkbox"/>	surface-mount
NXC/SM4814- <input type="checkbox"/>	surface-mount with 56" 4-bulb overhead light
NXC/RM4804- <input type="checkbox"/>	rear-mount for Align base
NXC/RM4814- <input type="checkbox"/>	rear-mount for Align base with 56" 4-bulb overhead light



Includes:

- (2) 12" deep shelves
- (1) 15" deep shelf
- (1) back stop
- (1) 16" high overhead cabinet with retractable door
- (1) 30" high louvered panel

PART NO.	DESCRIPTION
NXC/SM4825- <input type="checkbox"/>	surface-mount
NXC/RM4825- <input type="checkbox"/>	rear-mount for Align base



Includes:

- (2) 12" deep shelves
- (2) 30" high louvered panels

PART NO.	DESCRIPTION
NXC/SM4806- <input type="checkbox"/>	surface-mount
NXC/SM4816- <input type="checkbox"/>	surface-mount with 56" 4-bulb overhead light
NXC/RM4806- <input type="checkbox"/>	rear-mount for Align base
NXC/RM4816- <input type="checkbox"/>	rear-mount for Align base with 56" 4-bulb overhead light



Includes:

- (2) 16" high overhead cabinets with retractable doors
- (1) 30" high markerboard/tackboard
- (1) 30" high louvered panel

PART NO.	DESCRIPTION
NXC/SM4828- <input type="checkbox"/>	surface-mount
NXC/RM4828- <input type="checkbox"/>	rear-mount for Align base

NEXUS SYSTEM FRAMES

Building your ideal Nexus accessory system is an easy process. Simply select the frames (starters and adders) that fit your worksurface width, then pick accessories of corresponding widths to mount on the frames. Accessories are easily moved and repositioned as your needs change.



Nexus Surface-Mount Frames

Frames are sturdy, heavy gauge steel, and are notched front and back at 1" increments for mounting accessories. Starter frames consist of 2 upright posts and a horizontal rail. Adder sets consist of an additional upright and horizontal rail. Uprights are available in heights of 30" and 48", and 6 widths. Foot plate is 2 3/4" x 4". Specify color from chart on inside back cover.

30" High Surface-Mount Frames

PART NO.	SEC. WIDTH CENT.-TO-CENT.
Starter set	
NXF/SM2430	24"
NXF/SM3030	30"
NXF/SM3630	36"
NXF/SM4230	42"
NXF/SM4830	48"
NXF/SM6030	60"
Adder set	
NXF/SM2430A	24"
NXF/SM3030A	30"
NXF/SM3630A	36"
NXF/SM4230A	42"
NXF/SM4830A	48"
NXF/SM6030A	60"

48" High Surface-Mount Frames

PART NO.	SEC. WIDTH CENT.-TO-CENT.
Starter set	
NXF/SM2448	24"
NXF/SM3048	30"
NXF/SM3648	36"
NXF/SM4248	42"
NXF/SM4848	48"
NXF/SM6048	60"
Adder set	
NXF/SM2448A	24"
NXF/SM3048A	30"
NXF/SM3648A	36"
NXF/SM4248A	42"
NXF/SM4848A	48"
NXF/SM6048A	60"

For rear-mount Nexus systems for Align® Adjustable Height Workstations, see page 229.

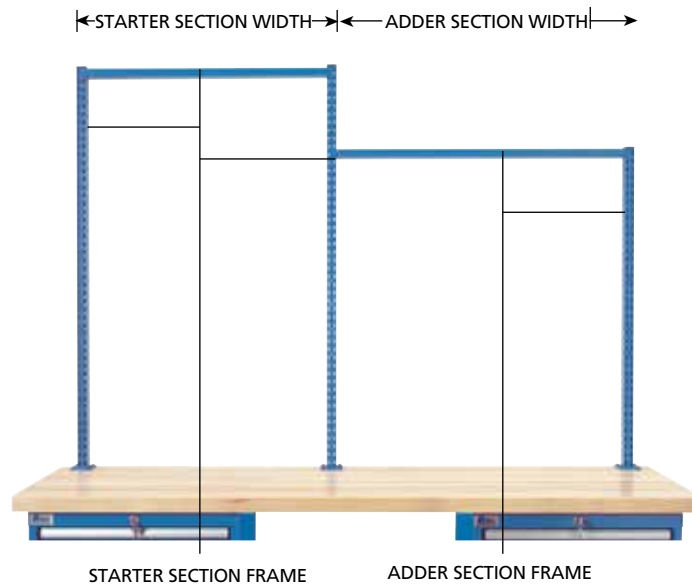

Available Widths of Nexus Systems

The widths below represent measurements from frame center to frame center. Uprights are 1 3/16" wide. Uprights must be mounted a minimum of 3" from edge of worksurface.

Using 1 Section

SECTION WIDTH (CENTER-TO-CENTER)	OVERALL WIDTH (FOOT-TO-FOOT)	MINIMUM WORK-SURFACE LENGTH	INSIDE USEABLE WIDTH
24"	26 3/4"	30"	22 3/4"
30"	32 3/4"	36"	28 3/4"
36"	38 3/4"	42"	34 3/4"
42"	44 3/4"	48"	40 3/4"
48"	50 3/4"	54"	46 3/4"
60"	62 3/4"	66"	58 3/4"

Using 1 Starter and 1 Adder Section

SECTION WIDTH (CENTER-TO-CENTER)	OVERALL WIDTH (FOOT-TO-FOOT)	MINIMUM WORKSURFACE LENGTH
24" + 24"	50 3/4"	54"
24" + 30"	56 3/4"	60"
24" + 36"	62 3/4"	66"
24" + 42"	68 3/4"	72"
24" + 48"	74 3/4"	78"
24" + 60"	86 3/4"	90"
30" + 30"	62 3/4"	66"
30" + 36"	68 3/4"	72"
30" + 42"	74 3/4"	78"
30" + 48"	80 3/4"	84"
30" + 60"	92 3/4"	96"
36" + 36"	74 3/4"	78"
36" + 42"	80 3/4"	84"
36" + 48"	86 3/4"	90"
36" + 60"	98 3/4"	102"
42" + 42"	86 3/4"	90"
42" + 48"	92 3/4"	96"
42" + 60"	104 3/4"	108"
48" + 48"	98 3/4"	102"
48" + 60"	110 3/4"	114"
60" + 60"	122 3/4"	126"

NEXUS SYSTEM SHELVES

Shelves must match the width of your chosen section frame (see previous page).

Specify color from chart on inside back cover.

Adjustable Shelves

Adjustable, heavy gauge steel shelves can be mounted parallel to the worksurface or at a 15° angle for easy, ergonomic access. They have a 100 lb. weight capacity for evenly distributed loads. Shelves are reversible, with the lip either at the front, or at the rear to act as a back stop. Supports are attached through a simple double-notch system into slots on the uprights.



Adjustable Shelves

PART NO.	SHELF WIDTH	SEC. WIDTH
12" deep		
NXS/A2412L	23 1/2"	24"
NXS/A3012L	29 1/2"	30"
NXS/A3612L	35 1/2"	36"
NXS/A4212L	41 1/2"	42"
NXS/A4812L	47 1/2"	48"
NXS/A6012L	59 1/2"	60"

15" deep

NXS/A2415L	23 1/2"	24"
NXS/A3015L	29 1/2"	30"
NXS/A3615L	35 1/2"	36"
NXS/A4215L	41 1/2"	42"
NXS/A4815L	47 1/2"	48"
NXS/A6015L	59 1/2"	60"

Shelf Dividers

Steel dividers fit over the edge of adjustable shelf when shelf is mounted at 0°. Base of divider can be ordered left or right of divider upright. Painted to match shelf.



Shelf Dividers

PART NO.	HEIGHT
For 12" deep adjustable shelves	
NXS/MD100-12/L	4"
NXS/MD100-12/R	4"
NXS/MD150-12/L	6"
NXS/MD150-12/R	6"
NXS/MD200-12/L	8"
NXS/MD200-12/R	8"

For 15" deep adjustable shelves

NXS/MD100-15/L	4"
NXS/MD100-15/R	4"
NXS/MD150-15/L	6"
NXS/MD150-15/R	6"
NXS/MD200-15/L	8"
NXS/MD200-15/R	8"

Variable Angle Shelves

Shelf adjusts into five positive positions from totally flat to a 25° angle and has a capacity of 150 lbs. for evenly distributed loads. Can be mounted in a forward or set-back position between uprights for maximum flexibility.



Variable Angle Shelves

PART NO.	SHELF WIDTH	SEC. WIDTH
18" deep		
NXS/V2418L	22 1/2"	24"
NXS/V3018L	28 1/2"	30"
NXS/V3618L	34 1/2"	36"
NXS/V4218L	40 1/2"	42"
NXS/V4818L	46 1/2"	48"
NXS/V6018L	58 1/2"	60"

24" deep

NXS/V2424L	22 1/2"	24"
NXS/V3024L	28 1/2"	30"
NXS/V3624L	34 1/2"	36"
NXS/V4224L	40 1/2"	42"
NXS/V4824L	46 1/2"	48"

NEXUS SYSTEM LIGHTING ACCESSORIES

Overhead Light Fixtures

- Fluorescent fixture is available in 2-bulb or 4-bulb model in 44" or 56" length.
- Tilts up or down 10°.
- Brackets allow light fixture to be mounted to frame sections 30" to 90" wide.
- Kit includes switch and 8' grounded electrical cord, support track, standard acrylic diffuser and T8 bulbs. **Requires NX/OHL-TR/BRK support brackets (see right).**
- Fixture available in Light Gray only, but brackets can be ordered in any Lista color (see back cover for color chart).
- Bracket with fixture can also simultaneously support tool rail (see next page).



Overhead Light Fixture Kits

PART NO.	FIXTURE WIDTH	SECTION WIDTH
2-bulb		
NX/OHL-R48/2	44"	30"-48"
NX/OHL-R60/2	56"	49"-60"
NX/OHL-R72/2	56"	61"-72"
NX/OHL-R78/2	56"	73"-78"
NX/OHL-R84/2	56"	79"-84"
NX/OHL-R90/2	56"	85"-90"

4-bulb

NX/OHL-R48/4	44"	30"-48"
NX/OHL-R60/4	56"	49"-60"
NX/OHL-R72/4	56"	61"-72"
NX/OHL-R78/4	56"	73"-78"
NX/OHL-R84/4	56"	79"-84"
NX/OHL-R90/4	56"	85"-90"

Overhead Light Fixtures Only

PART NO.	BULBS	WIDTH
NX/OHL44/2	2	44"
NX/OHL44/4	4	44"
NX/OHL56/2	2	56"
NX/OHL56/4	4	56"

Overhead Light and Tool Rail Support Brackets

Required for mounting overhead light fixture. Brackets come in pairs. Specify color (see inside back cover for color chart). See next page for tool rail options.

- 24" deep brackets can be used with a 24" deep worksurface (either surface- or rear-mount* Nexus frames), or a 30" deep worksurface with surface-mount frames.
- 30" deep brackets can be used with a 30" deep worksurface with rear-mount frames, or a 36" deep worksurface (either surface- or rear- mount frames).



Overhead Light and Tool Rail Support Brackets

PART NO.	BRACKET DEPTH
NX/OHL-TR/BRK24	24"
NX/OHL-TR/BRK30	30"

*rear-mount frames only available with Align® adjustable height bases

Undershelf Task Lights

Attach by magnet under shelves or overhead cabinets. Includes white acrylic wrap-around diffuser, switch, 6' cord and bulb.



Undershelf Task Lights

PART NO.	SIZE	BULB
FLF-18	18" W x 5" D x 1 3/4" H	F15T8
FLF-36/UCF	36" W x 5" D x 1 3/4" H	F25T8
FLF-48/UCF	48" W x 5" D x 1 3/4" H	F32T8

NEXUS SYSTEM TOOL RAILS AND POWER OPTIONS

Tool Rails

The tool rail spans the length of the worksurface. It is available in 48", 60" or 72" lengths. Each tool rail has a 30 lb. capacity, and comes complete with a trolley, 2 hangers, 2 endstops and 2 end caps in black finish. Balancer not included. **Requires support brackets (see previous page).** Fixture and bracket can also simultaneously support overhead light (see previous page). Color is black.



Tool Rails

PART NO.	LENGTH
TR48	48"
TR60	60"
TR72	72"



Swing Arm Tool Rail

PART NO.	LENGTH
SWT36	36"

Swing Arm Tool Rail

The swing arm tool rail is 36" in length and swings 180°. It has a 30 lb. capacity and includes a trolley, 1 endstop and 1 end cap. Includes mounting bracket. Balancer not included. Color is black.



Single Uprights

PART NO.	HEIGHT
NXF-P30/SM	30"
NXF-P48/SM	48"

Single Uprights

Economical solution to mounting power or articulating component above the surface. Capacity 60 lbs.

Airhose Attachment

PART NO.	DESCRIPTION
NX/AHB	bracket for air supply

Airhose Attachment

Small bracket attaches to frame upright. Quick-connect fitting not supplied.



Vertical Power Strips

PART NO.	DESCRIPTION
NXVPS/15	15 amp with 6 outlets
NXVPS/20	20 amp with 6 outlets
NXVPS/15GF	15 amp GFCI with 6 outlets
NXVPS/20GF	20 amp GFCI with 6 outlets

Vertical Power Strips

Mounts vertically to front and back of upright. Bracket and hardware supplied. Lighted on/off switch, 6' cord with grounded plug and circuit breaker are included. Fixture and brackets are black.



Horizontal Power Rails

PART NO.	
15 amp	20 amp
NXHPS/24-15	NXHPS/24-20
NXHPS/30-15	NXHPS/30-20
NXHPS/36-15	NXHPS/36-20
NXHPS/42-15	NXHPS/42-20
NXHPS/48-15	NXHPS/48-20
NXHPS/60-15	NXHPS/60-20

15 amp GFCI

PART NO.	
15 amp GFCI	20 amp GFCI
NXHPS/24-15GF	NXHPS/24-20GF
NXHPS/30-15GF	NXHPS/30-20GF
NXHPS/36-15GF	NXHPS/36-20GF
NXHPS/42-15GF	NXHPS/42-20GF
NXHPS/48-15GF	NXHPS/48-20GF
NXHPS/60-15GF	NXHPS/60-20GF

Horizontal Power Rails

Self-contained, 6-plug electrical outlet strip. Power rail pivots on axis, providing full horizontal adjustability. 110V, 15 amp or 20 amp circuit breaker.

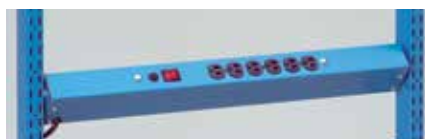

For items with choice of color, specify color from chart on inside back cover.

NEXUS SYSTEM PIVOTING ACCESSORIES

Articulating arms allow free and simple repositioning of a wide range of Nexus System accessories. Arm swings 180° for easy ergonomic access, and has a 75 lb. capacity. All accessories include arm and mounting bracket (mounting brackets are black). Specify color from chart on inside back cover.



Monitor Shelf with Keyboard Holder

Holds computer monitor. Includes retractable wire keyboard holder. 75 lb. capacity. 12 3/8" wide x 12 3/8" deep.



Optional Mouse Tray

Mouse tray attaches to monitor shelf with keyboard holder (above) to hold computer mouse and/or mouse pad. 75 lb. capacity. 9 1/2" wide x 7 5/8" deep. Ordered separately.



Equipment Shelf

Holds a variety of customer-supplied equipment or tools. 75 lb. capacity. 12 3/8" wide x 12 3/8" deep.



Accessory Shelf

For easy access to small tools, instruments, parts, etc. Ribbed mat optional. 21 1/4" wide x 7 3/8" deep. 75 lb. capacity.



Document Holder

For displaying papers, plans, etc. 11 7/8" wide x 13 3/4" high. Includes lip for pencils, pens, etc.

Large Document Holder

For displaying large documents, and open binders and books. 23 5/8" wide x 13 3/4" high. Includes lip for pencils, pens, etc.



Bin Container

Holds 3 rows of plastic bins for easy access to parts and components. Interior space per shelf is 20" wide x 6" deep. Top shelf is 3 1/4" high, second and third shelves are 3 3/4" high. Requires accessory shelf (left) for support (not included), or can be used freestanding. 50 lb. capacity. Does not include bin boxes.



Monitor Shelf with Keyboard Holder

PART NO.
NXA/MS-KB

Optional Mouse Tray

PART NO.
NX/MP

Equipment Shelf

PART NO.
NXA/ES

Accessory Shelf

PART NO.	DESCRIPTION
NXA/AS	shelf
NX/AS-MAT	ribbed rubber mat

Document Holder

PART NO.
NXA/DH

Large Document Holder

PART NO.
NXA/DHW

Bin Container

PART NO.
NX/AS-BC

Additional Monitor Arms can be found on pages 218-221.

NEXUS SYSTEM BACK PANELS AND MARKERBOARD/ TACKBOARDS

Sturdy panels easily attach between frame uprights. All panels are available in heights of 18" and 30".

Reversible markerboard/ tackboard attaches using same brackets (available in 30" height only).

Specify color from chart on inside back cover.

Louvered Back Panels

Steel louvered panel is designed to accommodate industry-standard plastic boxes that feature louvered edge or lip.

Pegboard Panels

Steel pegboard panel accepts all standard pegging devices (i.e. hooks, etc.). Pegboard holes are 1/4" in diameter. Ideal for placement of commonly used tools.

Solid Privacy Panels

Steel privacy panel encloses a section and can also be used to hold/display items with magnets.

Reversible Markerboard/Tackboards

Two-sided reversible board. Features white magnetic markerboard on one-side and gray fabric tackboard on the other. Also functions as privacy panel and sound dampener. 30" high.

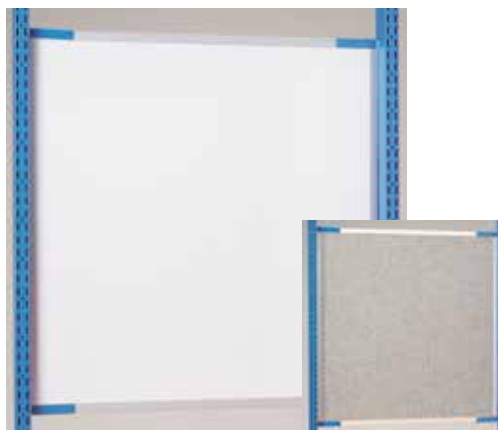
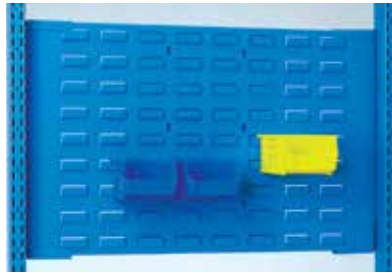

Louvered Back Panels

PART NO.	USE WITH SECTION WIDTH
18" high	
NXLP/2418	24"
NXLP/3018	30"
NXLP/3618	36"
NXLP/4218	42"
NXLP/4818	48"
NXLP/6018	60"
30" high	
NXLP/2430	24"
NXLP/3030	30"
NXLP/3630	36"
NXLP/4230	42"
NXLP/4830	48"
NXLP/6030	60"

Pegboard Panels

PART NO.	USE WITH SECTION WIDTH
18" high	
NXPP/2418	24"
NXPP/3018	30"
NXPP/3618	36"
NXPP/4218	42"
NXPP/4818	48"
NXPP/6018	60"
30" high	
NXPP/2430	24"
NXPP/3030	30"
NXPP/3630	36"
NXPP/4230	42"
NXPP/4830	48"
NXPP/6030	60"

Solid Privacy Panels

PART NO.	USE WITH SECTION WIDTH
18" high	
NXSP/2418	24"
NXSP/3018	30"
NXSP/3618	36"
NXSP/4218	42"
NXSP/4818	48"
NXSP/6018	60"
30" high	
NXSP/2430	24"
NXSP/3030	30"
NXSP/3630	36"
NXSP/4230	42"
NXSP/4830	48"
NXSP/6030	60"

Reversible Markerboard/ Tackboards

PART NO.	USE WITH SECTION WIDTH
NXRMT/2430	24"
NXRMT/3030	30"
NXRMT/3630	36"
NXRMT/4230	42"
NXRMT/4830	48"

OVERHEAD CABINETS

Ideal companion to Lista's modular storage cabinets or workstations, overhead cabinets bring organization to the storage of binders, bulk storage or any items that require constant access, ample room and safe secure storage.

Overhead cabinets are 15" deep and available in three heights (16", 20" & 29") and widths to match drawer cabinets, Nexus frames and workbench risers. Overhead cabinets can also be in numerous ways. Mounted onto Riser shelves, Rear mount frame system for cabinets, with wall mounting brackets, onto Nexus uprights, to the side of a cabinet or directly to wall. All mounting systems must be ordered separately.

Overhead cabinets are available with no door, retractable door, hinged or sliding door options. Many doors have available window options. See chart for available door options based on overhead cabinet width and height. Retractable doors open into the cabinet and require 1" of vertical space. Hinged doors come in a set of two doors and are hinged at the edges of the cabinet, they have an inside panel to give a clean appearance and eliminated areas for debris to collect. Sliding doors bypass each other and give to one half of the cabinet at a time.

All overhead cabinets come standard with one bottom shelf. 29" cabinets come with the addition of one adjustable shelf that is adjustable at 1 1/2" increments and shelves have a usable depth of 13 1/2". Additional adjustable shelves can be ordered separately.

Multiple locking options are available as well including individual, keyed alike and master keying.

Canopy tops are available to prevent the top of the cabinet from being used for storage.

How to order a overhead cabinet

1. Select overhead cabinet based on your choice of dimensions.

2. ■ Select door type.

ND = no door

Door for 16" high overhead cabinets

RD = retractable door

Doors for 29" high overhead cabinets

HD = hinged doors

HDP* = hinged doors with steel-framed plexiglas

SD = sliding doors

SDP** = sliding doors with steel-framed plexiglas

**plexiglas doors available for cabinets 30" and wider only*

***plexiglas doors available for cabinets 42" and wider only*

3. ■ Select lock type.

RG = individual

KA = keyed-alike

MA = master

4. □ Select paint color (see inside back cover for color chart).

5. Order mounting brackets.

EXAMPLE: to order an OHC2416 overhead cabinet with a retractable door, an individual lock, and Bright Blue paint, the cabinet part number would be **OHC2416-RDRGBB**, and the mounting brackets would be **NX/OHC-BRK16**.



WORKBENCHES

16" OVERHEADS PART NO.	DOOR OPTION RETRACTABLE
OHC1716	✓
OHC2316	✓
OHC2416	✓
OHC2816	✓
OHC3016	✓
OHC3416	✓
OHC34.2516	✓
OHC3616	✓
OHC4016	✓
OHC4216	✓
OHC4516	✓
OHC4716	✓
OHC4816	✓
OHC5616	✓
OHC6016	✓

20" OVERHEADS PART NO.	DOOR OPTIONS RETRACTABLE	HINGED	SLIDING
OHC1720	✓	✓	
OHC2320	✓	✓	
OHC2420	✓	✓	
OHC2820	✓	✓	
OHC3020	✓	✓	
OHC3420	✓	✓	
OHC34.2520	✓	✓	
OHC3620	✓	✓	
OHC4020	✓	✓	✓
OHC4220	✓	✓	✓
OHC4520	✓	✓	✓
OHC4720	✓	✓	✓
OHC4820	✓	✓	✓
OHC5620	✓	✓	✓

29" OVERHEADS PART NO.	DOOR OPTIONS HINGED	SLIDING
OHC1729	✓	
OHC2329	✓	
OHC2429	✓	
OHC2829	✓	
OHC3029	✓	
OHC3429	✓	
OHC34.2529	✓	
OHC3629	✓	
OHC4029	✓	✓
OHC4229	✓	✓
OHC4529	✓	✓
OHC4729	✓	✓
OHC4829	✓	✓
OHC5629	✓	✓

Overhead Cabinet dimensions and extra shelf part numbers.

OHC MODEL	WIDTH IN.	WIDTH MM'S	TO MATCH	EXTRA SHELVES PART NO.
OHC17__	16.85	428.0	NS, NW	OHC-S17
OHC23__	22.20	564.0	CL, MP	OHC-S23
OHC24__	24.00	609.6	24"	OHC-S24
OHC28__	28.23	717.0	ST, SC	OHC-S28
OHC30__	30.00	762.0	30"	OHC-S30
OHC34__	33.70	856.0	2 x NS, NW	OHC-S34
OHC34.25__	34.25	870.0	ES, EW	OHC-S34.25
OHC36__	36.00	914.4	36"	OHC-S36
OHC40__	40.28	1023.0	HS, HW	OHC-S40
OHC42__	42.00	1066.8	42"	OHC-S42
OHC45__	44.96	1142.0	ML, MI	OHC-S45
OHC47__	46.97	1193.0	MS, MW	OHC-S47
OHC48__	48.00	1219.2	48"	OHC-S48
OHC56__	56.34	1431.0	HT, DW	OHC-S56
OHC60__	60.00	1524.0	60"	OHC-S60



OVERHEAD CABINETS (CONT)

Lista overhead cabinets can be mounted to a wall for stability and permanence. Mount either directly to the wall with customer-supplied hardware, or by using a Wall Mounting Kit.

Overhead cabinets can also be easily mounted atop an OHC stationary riser shelf for convenient support without having to mount the unit to the wall. Stationary riser shelves are available either with or without a back panel, and can be situated above any counter top.

Wall Mounting Kits

Brackets for mounting overhead cabinets to wall. Starter kit is required for first cabinet in row. One adder kit is required for each additional cabinet used. Starter kit includes brackets and end filler strips; adder kit includes brackets only. Color to match housing.



16" High Cabinet Wall Mounting Kits

STARTER PART NO.	ADDER PART NO.	USE WITH CAB. WIDTH
OHC-WB2316	OHC-WB23A	22 3/16"
OHC-WB2816	OHC-WB28A	28 1/4"
OHC-WB3016	OHC-WB30A	30"
OHC-WB3416	OHC-WB34A	33 3/4"
OHC-WB3616	OHC-WB36A	36"
OHC-WB4016	OHC-WB40A	40 1/4"
OHC-WB4216	OHC-WB42A	42"
OHC-WB4716	OHC-WB47A	47"
OHC-WB4816	OHC-WB48A	48"
OHC-WB5616	OHC-WB56A	56 1/2"

20" High Cabinet Wall Mounting Kits

STARTER PART NO.	ADDER PART NO.	USE WITH CAB. WIDTH
OHC-WB2320	OHC-WB23A	22 3/16"
OHC-WB2820	OHC-WB28A	28 1/4"
OHC-WB3020	OHC-WB30A	30"
OHC-WB3420	OHC-WB34A	33 3/4"
OHC-WB3620	OHC-WB36A	36"
OHC-WB4020	OHC-WB40A	40 1/4"
OHC-WB4220	OHC-WB42A	42"
OHC-WB4720	OHC-WB47A	47"
OHC-WB4820	OHC-WB48A	48"
OHC-WB5620	OHC-WB56A	56 1/2"

29" High Cabinet Wall Mounting Kits

STARTER PART NO.	ADDER PART NO.	USE WITH CAB. WIDTH
OHC-WB2329	OHC-WB23A	22 3/16"
OHC-WB2829	OHC-WB28A	28 1/4"
OHC-WB3029	OHC-WB30A	30"
OHC-WB3429	OHC-WB34A	33 3/4"
OHC-WB3629	OHC-WB36A	36"
OHC-WB4029	OHC-WB40A	40 1/4"
OHC-WB4229	OHC-WB42A	42"
OHC-WB4729	OHC-WB47A	47"
OHC-WB4829	OHC-WB48A	48"
OHC-WB5629	OHC-WB56A	56 1/2"

OHC Riser Shelves

Overhead cabinets can also be easily mounted atop an OHC stationary riser shelf for convenient support without having to mount the unit to the wall. Stationary riser shelves are available either with or without a back panel, and can be situated above any counter top.



OHC Riser Shelves

WIDTH	W/BACKSTOP	W/BACKSTOP STAINLESS STEEL	W/BACKSTOP & PEGBOARD	W/BACKSTOP & LOUVERED
48"	SRS/OHC48-2-15DX12C	SRS/OHC48-2SS-15DX12C	SRS/OHC48-2P-15DX12C	SRS/OHC48-2L-15DX12C
60"	SRS/OHC60-2-15DX12C	SRS/OHC60-2SS-15DX12C	SRS/OHC60-2P-15DX12C	SRS/OHC60-2L-15DX12C
72"	SRS/OHC72-2-15DX12C	SRS/OHC72-2SS-15DX12C	SRS/OHC72-2P-15DX12C	SRS/OHC72-2L-15DX12C
84"	SRS/OHC84-2-15DX12C	SRS/OHC84-2SS-15DX12C	SRS/OHC84-2P-15DX12C	SRS/OHC84-2L-15DX12C
96"	SRS/OHC96-2-15DX12C	SRS/OHC96-2SS-15DX12C	SRS/OHC96-2P-15DX12C	SRS/OHC96-2L-15DX12C

OVERHEAD CABINETS (CONT)

Overhead Cabinet Nexus

Mounting Brackets

Brackets must be ordered for each overhead cabinet used. Comes in pairs.

PART NO.	FOR USE WITH
NX/OHC-BRK16	16" high cabinet
NX/OHC-BRK20	20" high cabinet
NX/OHC-BRK29	29" high cabinet

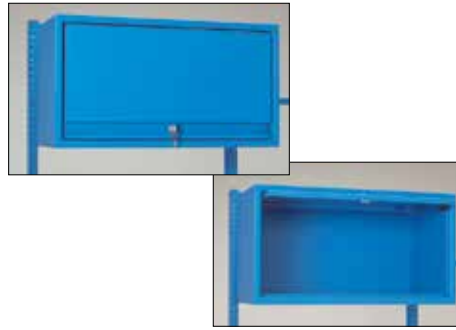

Overhead Cabinet Rear Mount Frame System

For mounting overhead cabinets above base cabinets without obstructing any of the worksurface. Contact your Lista sales representative for details.



Lista overhead cabinets can attach to a Nexus frame for protected, secure above-worksurface storage of large, bulky items.



NEXUS SYSTEM PLASTIC BOX RAILS AND BACK STOPS

Plastic Box Rails

The plastic box rail is easily adjustable for ergonomic access. It can be mounted parallel to the worksurface or at a 15° angle. The rail is attached via a simple double-notch system. It can hold select Lista or other boxes that have hanger lips at the rear for attaching to a louvered panel.



Plastic Box Rails

PART NO.	WIDTH	MAXIMUM # OF 3" BOXES/RAIL
NXBR/24	24"	7
NXBR/30	30"	9
NXBR/36	36"	11
NXBR/42	42"	13
NXBR/48	48"	15
NXBR/60	60"	19

Back Stops

Prevents items from rolling off worksurface. 3" in height. Painted to match frame.



Back Stops

PART NO.	USE WITH SECTION WIDTH
NXBS/24	24"
NXBS/30	30"
NXBS/36	36"
NXBS/42	42"
NXBS/48	48"
NXBS/60	60"

NEXUS SYSTEM STATIONARY STANDS AND MOBILE TROLLEYS

Nexus stationary stands and mobile trolleys are the perfect complement to any production, repair or assembly workspace. Hold and/or transport parts, tools, test equipment and almost anything else you can think of, with the convenience of a small footprint.

Designed to accept all Nexus System accessories, these mini-workstations can be configured to exactly suit your needs. For the complete range of Nexus accessories, see pages 234–239.

- Shelves, page 235
- Lights, page 236
- Power, page 237
- Pivoting accessories, page 238

Stands are available in four heights (48", 60", 72" and 84") and six widths (24", 30", 36", 42", 48" and 60"). Trolleys are available in the same widths, and in heights of 48" and 60" (casters add an additional 6" to overall height).

Stands and trolleys can be ordered in either rear-justified or center-justified configurations.

Add a worksurface, and your Nexus stand becomes an economical workbench.

For weight capacities for stationary stands and mobile trolleys contact your Lista representative.

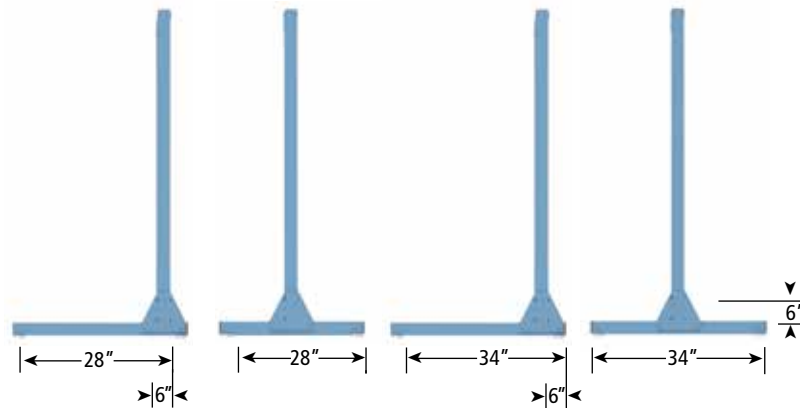

Rear-Justified
Stand or Trolley

For 24" deep
Worksurface

Center-Justified
Stand or Trolley

For 12" deep
Shelves

Rear-Justified
Stand or Trolley

For 30" deep
Worksurface

Center-Justified
Stand or Trolley

For 15" deep
Shelves



NEXUS STATIONARY STAND FRAMES

Nexus stand frames consist of 2 upright posts and 2 horizontal rails, with 2 feet. Adder sets consist of an additional upright and 2 horizontal rails with 1 foot. Frames are sturdy, heavy gauge steel, and are notched front and back at 1" increments for mounting accessories. Includes 4 adjustable glides. Specify stand depth in place of blue box (■) in part number.

- 28 = 28" overall depth
- 34 = 34" overall depth



48" High Rear-Justified Frames

52 3/4" OAH, 42" available for panels

PART NO.	STARTER SET	ADDER SET
	NXF/FSR2448-■	NXF/FSR2448A-■
	NXF/FSR3048-■	NXF/FSR3048A-■
	NXF/FSR3648-■	NXF/FSR3648A-■
	NXF/FSR4248-■	NXF/FSR4248A-■
	NXF/FSR4848-■	NXF/FSR4848A-■
	NXF/FSR6048-■	NXF/FSR6048A-■

48" High Center-Justified

Frames

52 3/4" OAH, 42" available for panels

PART NO.	STARTER SET	ADDER SET
	NXF/FSC2448-■	NXF/FSC2448A-■
	NXF/FSC3048-■	NXF/FSC3048A-■
	NXF/FSC3648-■	NXF/FSC3648A-■
	NXF/FSC4248-■	NXF/FSC4248A-■
	NXF/FSC4848-■	NXF/FSC4848A-■
	NXF/FSC6048-■	NXF/FSC6048A-■

60" High Rear-Justified Frames

64 3/4" OAH, 54" available for panels

PART NO.	STARTER SET	ADDER SET
	NXF/FSR2460-■	NXF/FSR2460A-■
	NXF/FSR3060-■	NXF/FSR3060A-■
	NXF/FSR3660-■	NXF/FSR3660A-■
	NXF/FSR4260-■	NXF/FSR4260A-■
	NXF/FSR4860-■	NXF/FSR4860A-■
	NXF/FSR6060-■	NXF/FSR6060A-■

60" High Center-Justified

Frames

64 3/4" OAH, 54" available for panels

PART NO.	STARTER SET	ADDER SET
	NXF/FSC2460-■	NXF/FSC2460A-■
	NXF/FSC3060-■	NXF/FSC3060A-■
	NXF/FSC3660-■	NXF/FSC3660A-■
	NXF/FSC4260-■	NXF/FSC4260A-■
	NXF/FSC4860-■	NXF/FSC4860A-■
	NXF/FSC6060-■	NXF/FSC6060A-■

72" High Rear-Justified Frames

76 3/4" OAH, 66" available for panels

PART NO.	STARTER SET	ADDER SET
	NXF/FSR2472-■	NXF/FSR2472A-■
	NXF/FSR3072-■	NXF/FSR3072A-■
	NXF/FSR3672-■	NXF/FSR3672A-■
	NXF/FSR4272-■	NXF/FSR4272A-■
	NXF/FSR4872-■	NXF/FSR4872A-■
	NXF/FSR6072-■	NXF/FSR6072A-v

72" High Center-Justified

Frames

76 3/4" OAH, 66" available for panels

PART NO.	STARTER SET	ADDER SET
	NXF/FSC2472-■	NXF/FSC2472A-■
	NXF/FSC3072-■	NXF/FSC3072A-■
	NXF/FSC3672-■	NXF/FSC3672A-■
	NXF/FSC4272-■	NXF/FSC4272A-■
	NXF/FSC4872-■	NXF/FSC4872A-■
	NXF/FSC6072-■	NXF/FSC6072A-■

84" High Rear-Justified Frames

88 3/4" OAH, 78" available for panels

PART NO.	STARTER SET	ADDER SET
	NXF/FSR2484-■	NXF/FSR2484A-■
	NXF/FSR3084-■	NXF/FSR3084A-■
	NXF/FSR3684-■	NXF/FSR3684A-■
	NXF/FSR4284-■	NXF/FSR4284A-■
	NXF/FSR4884-■	NXF/FSR4884A-■
	NXF/FSR6084-■	NXF/FSR6084A-■

84" High Center-Justified

Frames

88 3/4" OAH, 78" available for panels

PART NO.	STARTER SET	ADDER SET
	NXF/FSC2484-■	NXF/FSC2484A-■
	NXF/FSC3084-■	NXF/FSC3084A-■
	NXF/FSC3684-■	NXF/FSC3684A-■
	NXF/FSC4284-■	NXF/FSC4284A-■
	NXF/FSC4884-■	NXF/FSC4884A-■
	NXF/FSC6084-■	NXF/FSC6084A-■

WORKSURFACES

For descriptions, see page 86. To order a bullnose edge, add "BN" to the end of the part number. **Requires worksurface brackets (see below).** For use with rear-justified frames only.



Worksurface Brackets

Required to attach worksurface (above) to stationary stand. Includes 2 brackets. **For use with rear-justified frames only.**

Worksurfaces

PART NO.	SIZE
BUTCHER BLOCK	
BTOP-2424	24" long x 24" deep
BTOP-3024	30" long x 24" deep
BTOP-3624	36" long x 24" deep
BTOP-4224	42" long x 24" deep
BTOP-4824	48" long x 24" deep
BTOP-6024	60" long x 24" deep
BTOP-30	30" long x 30" deep
BTOP-36	36" long x 30" deep
BTOP-42	42" long x 30" deep
BTOP-48	48" long x 30" deep
BTOP-60	60" long x 30" deep

PLASTIC LAMINATE

PTOP-2424	24" long x 24" deep
PTOP-3024	30" long x 24" deep
PTOP-3624	36" long x 24" deep
PTOP-4224	42" long x 24" deep
PTOP-4824	48" long x 24" deep
PTOP-6024	60" long x 24" deep
PTOP-30	30" long x 30" deep
PTOP-36	36" long x 30" deep
PTOP-42	42" long x 30" deep
PTOP-48	48" long x 30" deep
PTOP-60	60" long x 30" deep

Worksurface Brackets

PART NO.	FOR USE WITH
NX/WST-KIT/24	24" deep worksurface
NX/WST-KIT/30	30" deep worksurface

Nexus Mobile Trolley Frames 48" High Rear-Justified Frames 57 3/4" OAH, 42" available for panels

PART NO.	WIDTH
NXF/MTR2448-■	24"
NXF/MTR3048-■	30"
NXF/MTR3648-■	36"
NXF/MTR4248-■	42"
NXF/MTR4848-■	48"
NXF/MTR6048-■	60"

48" High Center-Justified Frames

PART NO.	WIDTH
NXF/MTC2448-■	24"
NXF/MTC3048-■	30"
NXF/MTC3648-■	36"
NXF/MTC4248-■	42"
NXF/MTC4848-■	48"
NXF/MTC6048-■	60"

60" High Rear-Justified Frames 69 3/4" OAH, 54" available for panels

PART NO.	WIDTH
NXF/MTR2460-■	24"
NXF/MTR3060-■	30"
NXF/MTR3660-■	36"
NXF/MTR4260-■	42"
NXF/MTR4860-■	48"
NXF/MTR6060-■	60"

60" High Center-Justified Frames

PART NO.	WIDTH
NXF/MTC2460-■	24"
NXF/MTC3060-■	30"
NXF/MTC3660-■	36"
NXF/MTC4260-■	42"
NXF/MTC4860-■	48"
NXF/MTC6060-■	60"

Mobile Trolley

Accessories

PART NO.	DESCRIPTION
CAST5X15-NB	(1) swivel 5" caster
CAST5X15-WB	(1) swivel 5" caster with wheel lock
NX/MT-HANDL	side handle

Nexus Mobile Trolley Frames

Nexus trolley frames consist of 2 upright posts and 2 horizontal rails, with 2 feet. Frames are sturdy, heavy gauge steel, and are notched front and back at 1" increments for mounting accessories. Supported by (4) 5" diameter casters, 2 swivel and 2 swivel with wheel locks. Includes a handle.



Mobile Trolley Accessories

Individual casters replace the ones that come with trolley. Handle is single handle.



PRECONFIGURED NEXUS SYSTEM STANDS AND TROLLEYS

Preconfigured stands (page 94) include leveling glides, and are 60", 72" or 84" high. Trolleys (page 95) include 2 swivel and 2 swivel with wheel locks 3 1/2" diameter casters (250 lb. capacity per caster), and a handle, and are either 48" or 60" high (plus height of casters). Stands and trolleys are 28" deep.

How to order an Preconfigured Nexus Stand or Trolley

1. Select Preconfigured stand or trolley.

2. ■ Select worksurface style

for models NXF/FSR01, NXF/FSR02, NXF/FSR03 and NXF/FSR04.

P2 = Plastic laminate
B2 = Butcher block

All worksurfaces have a bullnose front edge and are 24" deep.

3. ■ Select width.

24 = 24" wide
30 = 30" wide
36 = 36" wide
42 = 42" wide
48 = 48" wide
60* = 60" wide

*not available for models that include markerboard/tackboard

4. ■ Select height.

For stands:

60 = 60" high
72 = 72" high
84 = 84" high

For trolleys:

48 = 48" high
60 = 60" high

5. Select paint color. For color chart, see inside back cover.

EXAMPLE: to order an NXF/FSR04 stand that is 36" wide and 60" high, with a butcher block worksurface and Bright Blue paint, the part number would be **NXF/FSR04B2-3660BB**.

Front View: Rear-justified



30" HIGH LOUVERED PANEL

BACK STOP WORKSURFACE

Workstand

PART NO.	DESCRIPTION
NXF/FSR01 ■ ■ ■ <input type="checkbox"/>	starter
NXF/FSR01 ■ ■ ■ <input type="checkbox"/> A	adder

Side View: Rear-justified



12" DEEP ADJUSTABLE SHELF

12" DEEP ADJUSTABLE SHELF

BIN RAIL
BACK STOP WORKSURFACE

Workstand

PART NO.	DESCRIPTION
NXF/FSR02 ■ ■ ■ <input type="checkbox"/>	starter
NXF/FSR02 ■ ■ ■ <input type="checkbox"/> A	adder

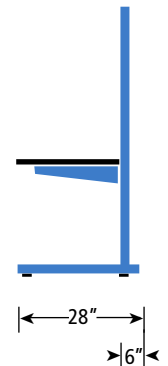

30" HIGH MARKER/TACKBOARD

BACK STOP WORKSURFACE

Workstand

PART NO.	DESCRIPTION
NXF/FSR03 ■ ■ ■ <input type="checkbox"/>	starter
NXF/FSR03 ■ ■ ■ <input type="checkbox"/> A	adder



18" DEEP VARIABLE ANGLE SHELF

18" DEEP VARIABLE ANGLE SHELF

BACK STOP WORKSURFACE

Workstand

PART NO.	DESCRIPTION
NXF/FSR04 ■ ■ ■ <input type="checkbox"/>	starter
NXF/FSR04 ■ ■ ■ <input type="checkbox"/> A	adder



30" HIGH MARKER/TACKBOARD

BIN RAIL
15 AMP HORIZONTAL POWER RAIL

Companion Stand

PART NO.	DESCRIPTION
NXF/FSR05 ■ ■ <input type="checkbox"/>	starter
NXF/FSR05 ■ ■ <input type="checkbox"/> A	adder



30" HIGH LOUVERED PANEL

Companion Stand

PART NO.	DESCRIPTION
NXF/FSR06 ■ ■ <input type="checkbox"/>	starter
NXF/FSR06 ■ ■ <input type="checkbox"/> A	adder



Front View: Rear-justified



Trolley
PART NO.
NXF/MTR07-

Side View: Rear-justified

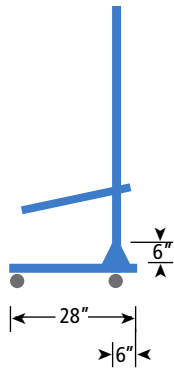

Front View: Rear-justified



Trolley
• Includes (2) 12" deep adjustable shelves

PART NO.
NXF/MTC08-

Side View: Rear-justified

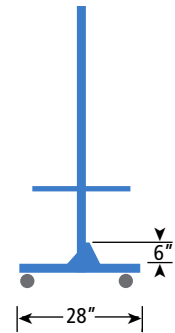

Bin Trolley

- 48" high trolley includes (1) 24" high and (1) 18" high louvered panels
- 60" high trolley includes (1) 30" high and (1) 24" high louvered panels

PART NO.
NXF/MTR09-

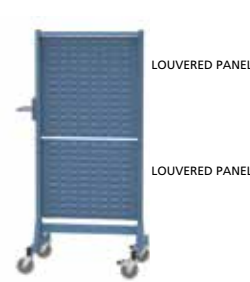
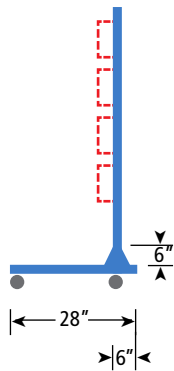

Bin Trolley

- 48" high trolley includes (2) 24" high and (2) 18" high louvered panels
- 60" high trolley includes (2) 30" high and (2) 24" high louvered panels

PART NO.
NXF/MTC10-

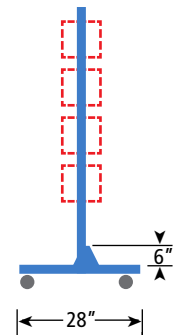

Shelf Trolley
PART NO.
NXF/MTR11-

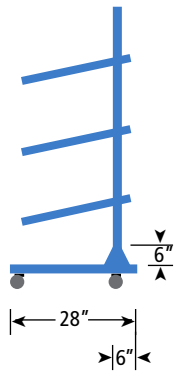

Shelf Trolley
• Includes (6) 12" deep adjustable shelves

PART NO.
NXF/MTC12-

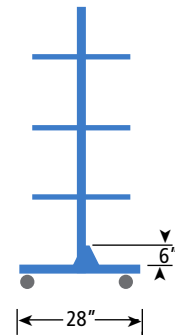

Caster Sets

- Allows individual flow rack frames to be movable
- Adds 6" to overall height
- For use with stand-alone starter frames without worksurfaces only
- 1,000 lb. capacity overall



Caster Sets

PART NO.	DESCRIPTION
NXFR/CAST5	set of (2) swivel & (2) swivel casters with wheel lock
CAST5X1S-NB	(1) swivel 5" caster
CAST5X1S-WB	(1) swivel with wheel lock 5" caster

Preconfigured Nexus Flow Rack Combinations

- The combinations below are configured to be most useful in a wide variety of applications

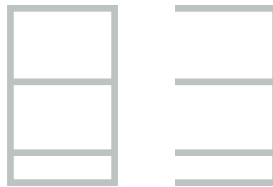

Combinations With 2 Shelves

STARTER SET PART NO.	ADDER SET PART NO.	WIDTH	EACH SHELF INCLUDES
NXFR/C3084-2	NXFR/C3084-2A	30"	(4) roller tracks and (1) guide
NXFR/C3684-2	NXFR/C3684-2A	36"	(4) roller tracks and (1) guide
NXFR/C4284-2	NXFR/C4284-2A	42"	(6) roller tracks and (2) guides
NXFR/C4884-2	NXFR/C4884-2A	48"	(6) roller tracks and (2) guides
NXFR/C6084-2	NXFR/C6084-2A	60"	(8) roller tracks and (3) guides



Combinations With 3 Shelves

STARTER SET PART NO.	ADDER SET PART NO.	WIDTH	EACH SHELF INCLUDES
NXFR/C3084-3	NXFR/C3084-3A	30"	(4) roller tracks and (1) guide
NXFR/C3684-3	NXFR/C3684-3A	36"	(6) roller tracks and (1) guide
NXFR/C4284-3	NXFR/C4284-3A	42"	(6) roller tracks and (2) guides
NXFR/C4884-3	NXFR/C4884-3A	48"	(9) roller tracks and (2) guides
NXFR/C6084-3	NXFR/C6084-3A	60"	(12) roller tracks and (3) guides

NEXUS SYSTEM FLOW RACKS

Nexus flow racks are an effective material handling solution for presenting parts for picking, kitting or assembly.

Parts delivery by gravity feeding cartons or parts bins reduces the need for parts delivery personnel, allowing one person to service more production or packaging stations. By assembling flow racks in rows, you can achieve even greater productivity and convenience.

Designed to accept any Nexus System accessories, flow racks can be configured to exactly suit your needs.

- Shelves
- Lights
- Power
- Pivoting accessories

Add a worksurface, and your stationary Nexus flow rack becomes a highly efficient assembly or work station.

Flow rack frames are 86 3/4" high and 48" deep, and are available in five widths (30", 36", 42", 48" and 60").

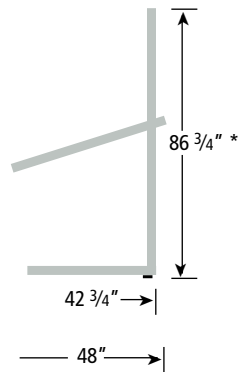

**casters add 6" to overall height;
leg kit adds 3" to overall height*

The Nexus Flow Rack is completely configurable, and can be equipped with such task-specific accessories as overhead lights, shelves and worksurfaces.



Fully configurable tracks and guides

Shelves can be mounted in a variety of positions and angles

Equipped with adjustable glides (some configurations available with casters for mobility)



NEXUS FLOW RACK FRAMES

Nexus flow rack starter frames consist of 4 upright posts and 8 horizontal rails. Adder sets consist of 2 additional uprights and 6 horizontal rails. Frames are sturdy, heavy gauge steel, and are notched front and back at 1" increments for mounting accessories. Includes 4 adjustable glides. 1,800 lb. weight capacity. Optional casters available (see page 249).

Nexus Flow Rack Roller Shelves

All tracks and guides are ordered individually (see page 250). 600 lb. weight capacity.

Nexus Flow Rack Shelf Accessories

Shelves are slotted on 1 1/2" increments to accept roller tracks and guides. Guides separate sections. Rollers are 1 1/16" wide; tracks are 1" wide. Two rollers are recommended for rows up to 15" wide, and 3 or more for wider rows.

Plastic Laminate Worksurfaces

Particle board core with plastic laminate top and sides. 1 9/16" thick. Dove gray is standard but other colors are available on request. To order a bullnose edge, add "BN" to the end of the part number. Requires worksurface bracket/foot kit (see below).

Worksurface Bracket/Foot Kits

Required to mount worksurface (above) to flow rack. Starter set includes 2 worksurface brackets, 2 feet, and 1 horizontal rail, and should be ordered for the first flow rack section that will have an attached worksurface. Adder sets include 2 worksurface brackets, 1 foot, and 1 horizontal rail, and should be ordered for all subsequent flow rack sections that will have an attached worksurface. Adds 3" to overall height.

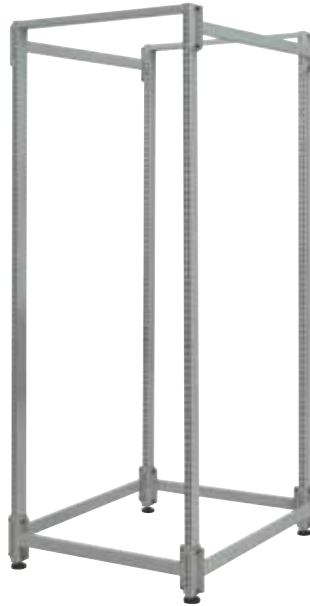

Nexus Flow Rack Frames]

PART NO.	STARTER SET	ADDER SET	WIDTH
NXFR/3084		NXFR/3084A	30"
NXFR/3684		NXFR/3684A	36"
NXFR/4284		NXFR/4284A	42"
NXFR/4884		NXFR/4884A	48"
NXFR/6084		NXFR/6084A	60"

Nexus Flow Rack Roller Shelves

PART NO.	# GUIDE/ROLLER HOLES	WIDTH
NXFR/S30	17	30"
NXFR/S36	21	36"
NXFR/S42	25	42"
NXFR/S48	29	48"
NXFR/S60	37	60"

Nexus Flow Rack Shelf Accessories

PART NO.	DESCRIPTION
NXFR/S-TRACK48	roller track
NXFR/S-GUIDE48	roller guide
NXFR/S-CLIP	replacement clip

Plastic Laminate Worksurfaces

PART NO.	24" DEEP	30" DEEP	WIDTH
PTOP-3024		PTOP-30	30"
PTOP-3624		PTOP-36	36"
PTOP-4224		PTOP-42	42"
PTOP-4824		PTOP-48	48"
PTOP-6024		PTOP-60	60"

Worksurface Bracket/Foot Kits

PART NO.	WORKSURF. SIZE
STARTER SET	
NXFR/WST-KIT/3024	30" x 24"
NXFR/WST-KIT/3624	36" x 24"
NXFR/WST-KIT/4224	42" x 24"
NXFR/WST-KIT/4824	48" x 24"
NXFR/WST-KIT/6024	60" x 24"
ADDER SET	
NXFR/WST-KIT/3030	30" x 30"
NXFR/WST-KIT/3630	36" x 30"
NXFR/WST-KIT/4230	42" x 30"
NXFR/WST-KIT/4830	48" x 30"
NXFR/WST-KIT/6030	60" x 30"



NEXUS SYSTEM PACKING BENCH ACCESSORIES

If you need to pack and ship products, and you want to get the job done quickly and efficiently, Lista delivers the complete package you've been looking for. Our advanced, modular benches are specifically designed for packing and shipping applications. Fully customizable, they will accommodate your needs today and in the future.

Lista's packing and shipping benches bundle together an array of superior features and benefits. Extremely flexible, the benches come in a variety of lengths (48" to 96") and depths and are available with a wide selection of worksurfaces, including butcher block, Lista Top, and galvanized or stainless steel over wood.

The addition of the Nexus System and its wide array of accessories means that your packing benches can be customized to exactly suit your needs, without a custom price.

TO ORDER AN
PRECONFIGURED COMBINATION
(preconfigured NEXUS system packing
bench), see pages 258–259.



NEXUS SYSTEM PACKING BENCH ACCESSORY FEATURES

Our packing benches can be configured with cabinet bases or legs to create a cost-effective, custom solution. With our modular drawer storage cabinets doubling as pedestals, users have systematic, efficient storage for their supplies, tools, paperwork and accessories.

Beneath the worksurface, vertical wire shelf dividers provide custom storage for corrugated or other bulk materials.

Above the worksurface, Lista's modular Nexus System provides a full range of accessories that offer easy access to packing materials at arm height. There are holders for rolls of paper, bubble rolls and labels. Vertical wire dividers are available to keep shelf storage organized. Other Nexus accessories include louvered panels to hold bins, plastic box rails, electrical attachments, overhead cabinets, computer monitor trays, document holders and many more (see pages 234–239).



NEXUS SYSTEM PACKING BENCH BELOW-WORKSURFACE ACCESSORIES

Packing benches can be designed using a full range of Lista workbench products:

- Technical workstation components, pages 182–187
- Industrial workbench components, pages 171–176
- Cabinet pedestals, pages 42–65
- Nexus System accessories, pages 236–243

The additional components shown on the following two pages enable you to equip a packing bench that exactly suits your needs.

How to order a packing bench bottom shelf

1. **Select part number** based on worksurface length.
2. **Specify left-hand** (facing the workbench) **bench support.**
 - TL** = Tech Leg
 - LL** = Lista Leg
 - NW** = NW cabinet
 - MP** = MP cabinet
3. **Specify right-hand** (facing the workbench) **bench support.**
 - TL** = Tech Leg
 - LL** = Lista Leg
 - NW** = NW cabinet
 - MP** = MP cabinet

EXAMPLE: to order a bottom shelf for a packing bench with a 72" worksurface, an MP Width cabinet as the left-hand pedestal and a Tech Leg as the right-hand support, the part number would be **BS-7216MPTL**.



Packing Bench Leg Inserts

For use with either technical or industrial legs. Allows multiple shelves and/or a roll holder to be mounted between legs. Not needed for applications using only one bottom shelf.

PART NO.	FOR LEG HEIGHT	USE WITH CAB. HEIGHT
WBPBB-27.5	27.5"	600 w/o base
WBPBB-29.5	29.5"	600 with 2" base
WBPBB-31.5	31.5"	600 with 4" base
WBPBB-33.5	33.5"	600 with 6" base or 750 w/o base
WBPBB-35.5	35.5"	750 with 2" base
WBPBB-39.5	39.5"	900 w/o base

Bottom Shelves

Heavy gauge steel shelf, 16" deep. Pre-punched holes accept vertical wire dividers. Applications using more than one bottom shelf and at least one leg support require packing bench leg insert(s) (see above).

PART NO.	WORKSURFACE LENGTH
BS-4816	48"
BS-6016	60"
BS-7216	72"
BS-8416	84"
BS-9616	96"

How to order a packing bench below-worksurface roll holder

1. Select part number based on worksurface length.
2. ■ Specify left-hand (facing the workbench) bench support.
 - TL** = Tech Leg
 - LL** = Lista Leg
 - NW** = NW cabinet
 - MP** = MP cabinet
3. ■ Specify right-hand (facing the workbench) bench support.
 - TL** = Tech Leg
 - LL** = Lista Leg
 - NW** = NW cabinet
 - MP** = MP cabinet

EXAMPLE: to order a roll holder for a packing bench with a 72" worksurface, an MP Width cabinet as the left-hand pedestal and a Tech Leg as the right-hand support, the part number would be **RH-72MP TL**.



Roll Holders (Leg/Cabinet Mount)

For dispensing paper, bubble rolls, etc. Holder mounts between tech panel legs, industrial panel legs and/or cabinet pedestals. Includes 1" diameter rod and brackets (unpainted galvanized steel). 100 lb. weight capacity.

Applications using at least one leg support require packing bench leg insert(s) (see left). Usable width varies by configuration. Contact Lista for exact dimensions.

PART NO.	WORKSURFACE LENGTH
RH-48 ■ ■	48"
RH-60 ■ ■	60"
RH-72 ■ ■	72"
RH-84 ■ ■	84"
RH-96 ■ ■	96"



Vertical Wire Dividers for Bottom Shelves

15" deep dividers are 1/4" diameter galvanized wire that fit into pre-punched holes in the 16" deep shelf. No hardware required.

PART NO.	HEIGHT
NXS/WD150-15	6"
NXS/WD250-15	10"
NXS/WD450-15	18"

NEXUS SYSTEM PACKING BENCH ABOVE-WORKSURFACE ACCESSORIES

For Nexus system frames, see page 234.
Specify color from chart on the inside
back cover.

Adjustable Shelves Without Lip

Adjustable steel shelf has a 100 lb. weight
capacity. Supports are attached through a
simple double-notch system that insert into
slots on the Nexus uprights. Available in
depths of 12" and 15". Pre-punched holes
accept vertical wire dividers (see below).



Adjustable Shelves Without Lip

PART NO.	SHELF WIDTH
12" deep	
NXS/A2412D	24"
NXS/A3012D	30"
NXS/A3612D	36"
NXS/A4212D	42"
NXS/A4812D	48"
NXS/A6012D	60"

15" deep

NXS/A2415D	24"
NXS/A3015D	30"
NXS/A3615D	36"
NXS/A4215D	42"
NXS/A4815D	48"
NXS/A6015D	60"

Vertical Wire Dividers for

Adjustable Shelves

PART NO.	HEIGHT
For 12" deep shelves	
NXS/WD150-12	6"
NXS/WD250-12	10"
NXS/WD450-12	18"

For 15" deep shelves

NXS/WD150-15	6"
NXS/WD250-15	10"
NXS/WD450-15	18"

Deep Shelves Without Lip

PART NO.	SHELF WIDTH
18" deep	
NXS/V2418D	24"
NXS/V3018D	30"
NXS/V3618D	36"
NXS/V4218D	42"
NXS/V4818D	48"
NXS/V6018D	60"

24" deep

NXS/V2424D	24"
NXS/V3024D	30"
NXS/V3624D	36"
NXS/V4224D	42"
NXS/V4824D	48"

Vertical Wire Dividers for Deep

Shelves

PART NO.	HEIGHT
For 18" deep shelves	
NXS/WD150-18	6"
NXS/WD250-18	10"
NXS/WD450-18	18"
For 24" deep shelves	
NXS/WD150-24	6"
NXS/WD250-24	10"
NXS/WD450-24	18"

Vertical Wire Dividers for Adjustable Shelves

Dividers are 1/4" diameter galvanized wire
that fit into pre-punched holes in the shelf.
No hardware required. Depth must match
shelf depth.



Deep Shelves Without Lip

Shelves are 18" or 24" deep with a
150 lb. weight capacity. Can be mounted
in a forward or set-back position between
uprights for maximum flexibility.
Pre-punched holes accept vertical wire
dividers (see below).



Vertical Wire Dividers for Deep Shelves

Dividers are 1/4" diameter galvanized wire
that fit into pre-punched holes in the shelf.
No hardware required. Depth must match
shelf depth.



Roll Holders (Extended Mount)

For dispensing paper, bubble rolls, etc. Includes 1" diameter rod and brackets. Brackets mount to Nexus uprights and extend 3" forward from the face of the uprights to allow for larger diameter rolls. Rod is unpainted galvanized steel; brackets are painted to match frame. 100 lb. weight capacity.



Label/Roll Holders (Interior Mount)

For dispensing labels and other smaller rolls. Brackets mount flush between Nexus uprights. Includes 1" diameter rod and brackets. Rod is unpainted galvanized steel; brackets are painted to match frame. 100 lb. weight capacity.



Roll Holders (Extended Mount)

PART NO.	USE WITH SECTION WDT.	USB. INSIDE WIDTH
NXRH/E24	24"	22"
NXRH/E30	30"	28"
NXRH/E36	36"	34"
NXRH/E42	42"	40"
NXRH/E48	48"	46"
NXRH/E60	60"	58"

Label/Roll Holders (Interior Mount)

PART NO.	USE WITH SECTION WDT.	USB. INSIDE WIDTH
NXRH/C24	24"	22"
NXRH/C30	30"	28"
NXRH/C36	36"	34"
NXRH/C42	42"	40"
NXRH/C48	48"	46"
NXRH/C60	60"	58"



Nexus stands and trolleys can be configured with Nexus packing bench accessories to make an ideal addition to any packing or shipping area. See pages 234–257.

PRECONFIGURED NEXUS SYSTEM PACKING BENCH COMBINATIONS

The packing benches shown on the following two pages are preconfigured to include the most popular and versatile styles of packing benches we offer. To design a custom bench to suit your exact needs, see pages 252-257.

Easy-Order packing benches include technical panel legs, and are 33 1/2" high. Optional Nexus System packing bench combinations are 48" high.

How to order an Preconfigured Packing Bench

1. Select Preconfigured packing bench.

2. Select worksurface style.

- LTS = Lista Top
- GLS = Galvanized steel
- BTS = Butcher block

All worksurfaces have a standard square edge and are 30" deep.

3. Select worksurface size.

- 4830 = 48" long x 30" deep
- 6030 = 60" long x 30" deep
- 7230 = 72" long x 30" deep

4. Select paint color. For color chart, see inside back cover.

How to order an optional Preconfigured Nexus System Packing Bench Combination

1. Select Preconfigured Nexus System.

2. Select system length (length must correspond to worksurface length as shown below).

- 42 = for 48" long worksurface
- 48 = for 60" long worksurface
- 60 = for 72" long worksurface

4. Select paint color. For color chart, see inside back cover.

EXAMPLE: to order a PS6200 packing bench with a 72" long butcher block worksurface and a matching Nexus System combination with Bright Blue paint, the bench part number would be **PS6200-BTS7230BB**, and the Nexus System part number would be **NXC/SM48-PB01-60BB**.

Single Bay Packing Benches

FRONT VIEW



- 5" HIGH HANGING CABINET
- BOTTOM SHELF
- BOTTOM SHELF

PART NO.
PS6000-

INCLUDES
WBHC150-1 hanging cabinet

SIDE VIEW

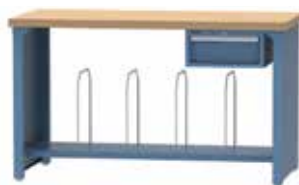
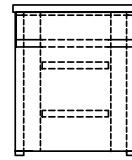

- 5" HIGH HANGING CABINET
- WIRE DIVIDERS
- BOTTOM SHELF

PART NO.
PS6100-

INCLUDES
WBHC150-1 hanging cabinet

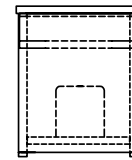

- PART NO.
PS6100-
- ROLL HOLDER

PART NO.
PS6200-

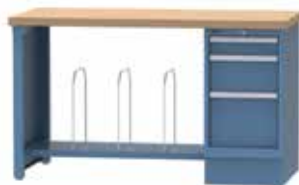
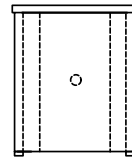

- 3" HIGH DRAWER
- 7" HIGH DRAWER
- FILE DRAWER
- WIRE DIVIDERS
- BOTTOM SHELF
- 6" BASE

PART NO.
PS6300-

INCLUDES
NW0600-0303N-F6RG cabinet

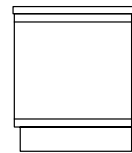

Optional Nexus System Packing Bench Combination



- STARTER UPRIGHTS
- WIRE DIVIDERS
- ADJUSTABLE SHELF
- HORIZONTAL RAIL
- ADJUSTABLE SHELF
- ROLL HOLDER
- LOUVERED PANEL

PART NO.
NXC/SM48-PB01-

HEIGHT
48"

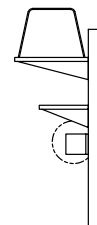

How to order a long Preconfigured Packing Bench

1. Select Preconfigured packing bench.

2. Select worksurface style.

- LTS = Lista Top
- GLS = Galvanized steel
- BTS = Butcher block

All worksurfaces have a standard square edge and are 30" deep.

3. Select worksurface size.

- 7230 = 72" long x 30" deep
- 8430 = 84" long x 30" deep
- 9630 = 96" long x 30" deep

4. Select paint color. For color chart, see inside back cover.

Long Packing Benches

FRONT VIEW



ROLL HOLDER

WIRE DIVIDERS

BOTTOM SHELF

SIDE VIEW

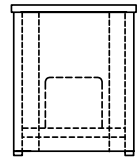

PART NO.

PS6400-

ROLL HOLDER LENGTH

72" top: 36" long; 84" & 96" top: 48" long

BOTTOM SHELF LENGTH

72" & 84" top: 24 1/4" long; 96" top: 36 1/4" long

BOTTOM SHELF

BOTTOM SHELF



5" HIGH HANGING CABINET

WIRE DIVIDERS

BOTTOM SHELF

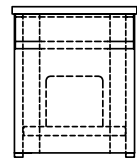

PART NO.

PS6500-

INCLUDES

WBHC 150-1 hanging cabinet

BOTTOM SHELF LENGTH

all shelves are equal length

BOTTOM SHELF

BOTTOM SHELF



3" HIGH DRAWER

7" HIGH DRAWER

FILE DRAWER

6" BASE

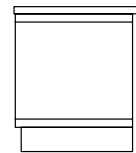

PART NO.

PS6600-

INCLUDES

NW0600-0303N-F6RG cabinet

2" HIGH DRAWER
2" HIGH DRAWER
3" HIGH DRAWER
5" HIGH DRAWER
7" HIGH DRAWER

6" BASE

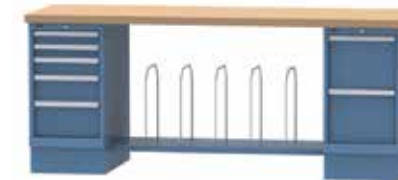

FILE DRAWER

FILE DRAWER

WIRE DIVIDERS

BOTTOM SHELF

6" BASE

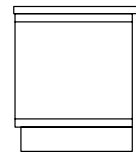

PART NO.

PS6700-

INCLUDES

NW0600-0501N-F6RG and NW0600-0201N-F6RG cabinets

How to order an optional Preconfigured Nexus System Packing Bench Combination

1. Select Preconfigured Nexus System.

2. Select system length (length must correspond to worksurface length as shown below).

- 66 = for 72" long worksurface
- 78 = for 84" long worksurface
- 90 = for 96" long worksurface

4. Select paint color. For color chart, see inside back cover.

EXAMPLE: to order a PS6600 packing bench with an 84" long butcher block worksurface and a matching Nexus System combination with Bright Blue paint, the bench part number would be **PS6600-BTS8430BB**, and the Nexus System part number would be **NXC/SM48-PB02-78BB**.

Optional Nexus System Packing Bench Combination

STARTER AND ADDER UPRIGHTS

WIRE DIVIDERS
ADJUSTABLE SHELF
HORIZONTAL RAIL
ADJUSTABLE SHELF

ROLL HOLDER

LOUVERED PANEL

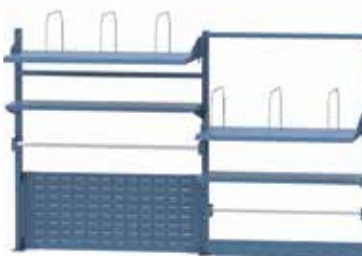

HORIZONTAL RAIL

WIRE DIVIDERS

ADJUSTABLE SHELF

ADJUSTABLE SHELF

ROLL HOLDER

BACK STOP

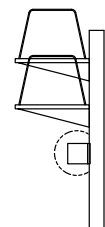

PART NO.

NXC/SM48-PB02-

HEIGHT

48"

STARTER SECTION WIDTH

42"

ADDER SECTION WIDTHS

24" for 72" worksurface, 36" for 84" worksurface, 48" for 96" worksurface

DRAWER ACCESSORIES

p.262-271



HOW TO ORDER CUSTOM DRAWER PARTITIONS AND DIVIDERS

These are the basic steps required for ordering custom drawer partitions and dividers from Lista.

The Lista drawer subdivision system

Lista drawers are subdivided using 2 basic accessories: partitions, which divide the drawer into rows, and dividers, which define compartments within those rows.

The part designations for ordering partitions or dividers have 3 components:

1. **A letter or letters prefix indicating the part.** "P" is for slotted drawer partitions, "LP" is for plain drawer partitions, and "D" is for drawer dividers.
2. **A number indicating the drawer model (height) number,** and therefore the height of the partition or divider.
3. **A number indicating the length of the partition or divider** in slots/units.

Drawer slot/unit dimensions are as follows:

DRAWER STYLE	WIDTH	DEPTH
NW	19 units	36 units
MP	27 units	36 units
SC	36 units	36 units
EW	45 units	36 units
HW	54 units	36 units
MW	64 units	36 units
DW	78 units	36 units

The examples to the right use an HS Width shallow depth cabinet drawer (40 1/4" wide) which has 54 slots/units side to side and 27 slots/units front to back.

Easy-Order Drawer Interior Sets:

Preconfigured drawer interior sets (see pages 32-39 and 66-75) for many popular drawer layouts are available for all sizes of Lista drawers:

DRAWER STYLE	WIDTH	DEPTH
NS	19 units	27 units
CL	27 units	27 units
S	36 units	27 units
ES	45 units	27 units
HS	54 units	27 units
MS	64 units	27 units
HT	78 units	27 units



Slotted and Plain Drawer Partitions

Partitions can divide a drawer into either horizontal or vertical rows.

The length of the partitions used in a drawer is determined by the number of slots/units in the drawer, front to back or side to side.

EXAMPLE A: if you want to divide a model HS100F drawer into 3 sections each, running front to back, order 2 slotted drawer partitions **P100-27**.

- P** = slotted drawer partition
- 100** = drawer height model number
- 27** = units front to back

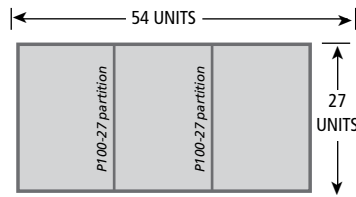

EXAMPLE B: if you want to divide the same drawer into 3 sections running side to side, order 2 slotted partitions **P100-54**.

- P** = slotted drawer partition
- 100** = drawer height model number
- 54** = units side to side

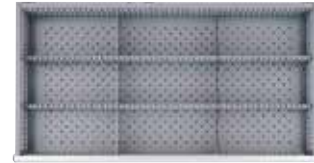
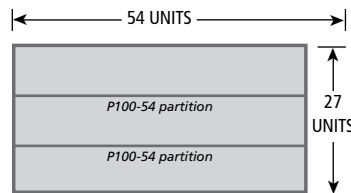

Steel Drawer Dividers

To further divide drawers into smaller compartments, order aluminum drawer dividers. To divide each of the 3 sections in the previous examples into 3 smaller sections, you would order 2 drawer dividers for each large section or a total of 6. **To subdivide drawers using dividers, you must specify slotted drawer partitions.**

EXAMPLE A: if you have divided the drawer into 3 equal sections running front to back, each section is 18 slots/ units wide ($54 \div 3 = 18$). So order 6 **D100-18** dividers.

- D** = drawer divider
- 100** = drawer height model number
- 18** = units wide

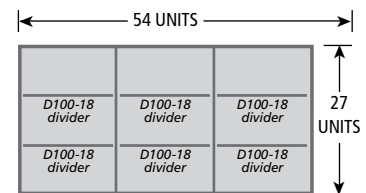

EXAMPLE B: if you have divided the drawer into 3 equal rows running side to side, each section is 9 slots/ units wide ($27 \div 3 = 9$). So order 6 **D100-9** dividers.

- D** = drawer divider
- 100** = drawer height model number
- 9** = units wide

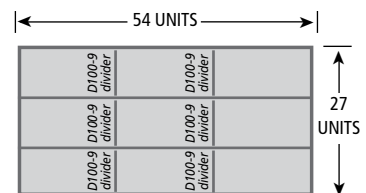

PARTITIONS AND DIVIDERS

Slotted Drawer Partitions

These slotted steel sheet partitions are the basic drawer dividers. They divide drawers into small or large compartments by length and/or width. Partition ends slide easily into drawer sidewall slots and can be bolted to the perforated drawer bottom. Partitions are slotted at $2\frac{1}{32}$ " intervals to match the drawer sidewalls and should be ordered to match particular drawer heights, widths and depths (see chart). Color: gray.



Slotted Drawer Partitions

USED W/ DRAWER TYPE		75	100/125	150/175	200/225	250/275	300 and up
PARTITION HEIGHT		2"	3"	4.9"	6.9"	8.9"	10.8"
LENGTH IN UNITS/INCHES		SLOTTED PARTITION PART NUMBERS					
UNITS	INCHES	PART NO.	PART NO.	PART NO.	PART NO.	PART NO.	PART NO.
19	12.64	P75-19	P100-19	P150-19	P200-19	P250-19	P300-19
27	17.99	P75-27	P100-27	P150-27	P200-27	P250-27	P300-27
36	24.02	P75-36	P100-36	P150-36	P200-36	P250-36	P300-36
45	30.04	P75-45	P100-45	P150-45	P200-45	P250-45	P300-45
54	36.06	P75-54	P100-54	P150-54	P200-54	P250-54	P300-54
64	42.76	P75-64	P100-64	P150-64	P200-64	P250-64	P300-64
78	52.13	P75-78	P100-78	P150-78	P200-78	P250-78	P300-78

Plain Drawer Partitions

For use when drawers will not be subdivided using dividers. These non-slotted steel sheet partitions divide drawers into larger compartments either by length or width. Bottom strips can be bolted to the perforated drawer bottom for additional stability, and the ends slide into slots in drawer sidewalls or slotted drawer partitions. Plain partitions should be ordered to match drawer sidewall height. Color: gray.

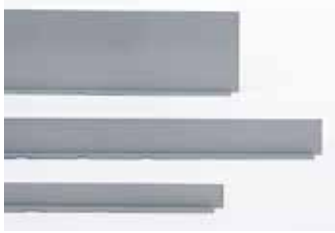

Plain Drawer Partitions

USED W/ DRAWER TYPE		75	100/125	150/175	200/225	250/275	300 and up
PARTITION HEIGHT		2"	3"	4.9"	6.9"	8.9"	10.8"
LENGTH IN UNITS/INCHES		PLAIN PARTITION PART NUMBERS					
UNITS	INCHES	PART NO.	PART NO.	PART NO.	PART NO.	PART NO.	PART NO.
19	12.64	LP75-19	LP100-19	LP150-19	LP200-19	LP250-19	LP300-19
27	17.99	LP75-27	LP100-27	LP150-27	LP200-27	LP250-27	LP300-27
36	24.02	LP75-36	LP100-36	LP150-36	LP200-36	LP250-36	LP300-36
45	30.04	LP75-45	LP100-45	LP150-45	LP200-45	LP250-45	LP300-45
54	36.06	LP75-54	LP100-54	LP150-54	LP200-54	LP250-54	LP300-54
64	42.76	LP75-64	LP100-64	LP150-64	LP200-64	LP250-64	LP300-64
78	52.13	LP75-78	LP100-78	LP150-78	LP200-78	LP250-78	LP300-78

Drawer Slot Snap-On Label Holders

Clip-on label holders (not included, see page 264—chart) can be attached to these durable red plastic holders, which fit all slotted partitions or slotted drawer walls for labeling adjacent drawer contents. Angled for easier reading.

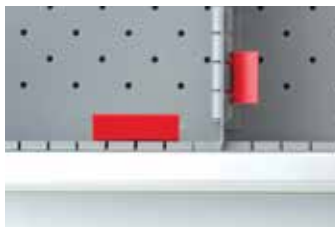

PART NO.	WIDTH	HEIGHT
SLH-1	1-3/16" (30mm)	5/8" (16mm)
SLH-2	2" (50mm)	5/8" (16mm)

PARTITIONS AND DIVIDERS

Steel Drawer Dividers

Dividers subdivide drawers into smaller compartments for specialized storage. Steel dividers come in a variety of lengths and slip into slots in drawer sidewalls and/or slotted drawer partitions. Top edges are rounded and smooth for safety. Full-width angled top can accommodate most text and barcode labels. Dividers can be fastened to drawer bottom for greater stability (fasteners included). Dividers should be ordered to match drawer sidewall height.



Steel Drawer Dividers

USED W/ DRAWER TYPE	75	100/125	150/175	200/225	250/275	300 and up	
DIVIDER HEIGHT	2"	3"	4.9"	6.9"	8.9"	10.8"	
LENGTH IN UNITS/INCHES	DRAWER DIVIDER PART NUMBERS						
UNITS	INCHES	PART NO.	PART NO.	PART NO.	PART NO.	PART NO.	PART NO.
3	1.87	D075-03S	D100-03S	D150-03S	D200-03S	D250-03S	D300-03S
4	2.54	D075-04S	D100-04S	D150-04S	D200-04S	D250-04S	D300-04S
5	3.21	D075-05S	D100-05S	D150-05S	D200-05S	D250-05S	D300-05S
6	3.88	D075-06S	D100-06S	D150-06S	D200-06S	D250-06S	D300-06S
7	4.55	D075-07S	D100-07S	D150-07S	D200-07S	D250-07S	D300-07S
8	5.21	D075-08S	D100-08S	D150-08S	D200-08S	D250-08S	D300-08S
9	5.88	D075-09S	D100-09S	D150-09S	D200-09S	D250-09S	D300-09S
10	6.55	D075-10S	D100-10S	D150-10S	D200-10S	D250-10S	D300-10S
12	7.89	D075-12S	D100-12S	D150-12S	D200-12S	D250-12S	D300-12S
15	9.9	D075-15S	D100-15S	D150-15S	D200-15S	D250-15S	D300-15S
18	11.91	D075-18S	D100-18S	D150-18S	D200-18S	D250-18S	D300-18S

Clip-on Label Holder

Black plastic label holders easily clip onto Lista aluminum drawer dividers, plastic boxes and tray dividers. When labeled using Lista Script software, DLH-1 holders use 18.787 labels; DLH-2 holders use 18.786 labels; DLH-3 holders use 18.785 labels.



Clip-on Label Holder

PART NO.	FOR USE WITH
DLH-1	plastic box dividers PB-24D, PB-24ASD
	slotted grooved tray
	dividers STD-2, STD-3, STD-4
	conductive slotted grooved tray dividers STD-3AS, AS
	grooved tray divider 2GTD
	drawer slot snap-on label holder SLH-1
DLH-2	drawer slot snap-on label holder SLH-2
DLH-3	all aluminum drawer dividers

PLASTIC BOXES

Plastic Boxes

Made of high impact polystyrene (HIPS) red plastic, these boxes are for storing small parts. Boxes slip in and out of drawers or plastic box rails for easy loading and dispensing and have label holder slots. Boxes should be ordered to match particular drawer height.



Plastic Boxes: Shallow Depth

PART NO.	NUMBER/HT.	L X W X H	FOR DRAWER						
			MAXIMUM BOXES PER SHALLOW DEPTH DRAWER STYLE						
			NS	CL	ST	ES	HS	MS	HT
PB-1	75	3" x 3" x 1"	24	36	48	60	72	84	102
PB-2	75	3" x 3" x 1"	24	36	48	60	72	84	102
PB-3	12	3" x 6" x 1"	12	18	24	30	36	42	51
PB-4	6	6" x 6" x 1"	6	9	12	15	18	21	24
PB-5	75	3" x 3" x 2"	24	36	48	60	72	84	102
PB-6	75	3" x 6" x 2"	12	18	24	30	36	42	51
PB-7	75	6" x 6" x 2"	6	9	12	15	18	21	24
PB-8	100	3" x 6" x 3"	12	18	24	30	36	42	51
PB-9	100	6" x 6" x 3"	6	9	12	15	18	21	24
PB-24	75	2" x 4" x 2"	27	36	54	63	81	90	117

PB-8DDivider for PB-8 plastic box

PB-24DDivider for PB-24 plastic box

Plastic Boxes: Full Depth

PART NO.	NUMBER/HT.	L X W X H	FOR DRAWER						
			MAXIMUM BOXES PER FULL DEPTH DRAWER STYLE						
			NW	MP	SC	EW	HW	MW	DW
PB-1	32	3" x 3" x 1"	32	48	64	80	96	112	136
PB-2	32	3" x 3" x 1"	32	48	64	80	96	112	136
PB-3	16	3" x 6" x 1"	16	24	32	40	48	56	68
PB-4	8	6" x 6" x 1"	8	12	16	20	24	28	32
PB-5	75	3" x 3" x 2"	32	48	64	80	96	112	136
PB-6	75	3" x 6" x 2"	16	24	32	40	48	56	68
PB-7	75	6" x 6" x 2"	8	12	16	20	24	28	32
PB-8	100	3" x 6" x 3"	16	24	32	40	48	56	68
PB-9	100	6" x 6" x 3"	8	12	16	20	24	28	32
PB-24	75	2" x 4" x 2"	36	54	72	90	108	126	156



PLASTIC BOXES

Conductive Plastic Boxes

Made of conductive black high impact polystyrene (HIPS) for storing electrostatically sensitive components or devices. Boxes slip in and out for easy loading and dispensing and have label holder slots. Order to match drawer height.



Conductive Plastic Boxes: Shallow Depth

PART NO.	NUMBER/HT.	L X W X H	FOR DRAWER						
			NS	CL	ST	ES	HS	MS	HT
PB-1AS		3" x 3" x 1"	24	36	48	60	72	84	102
PB-2AS		3" x 3" x 1"	24	36	48	60	72	84	102
PB-3AS		3" x 6" x 1"	12	18	24	30	36	42	51
PB-4AS		6" x 6" x 1"	6	9	12	15	18	21	24
PB-5AS	75	3" x 3" x 2"	24	36	48	60	72	84	102
PB-6AS	75	3" x 6" x 2"	12	18	24	30	36	42	51
PB-7AS	75	6" x 6" x 2"	6	9	12	15	18	21	24
PB-8AS	100	3" x 6" x 3"	12	18	24	30	36	42	51
PB-9AS	100	6" x 6" x 3"	6	9	12	15	18	21	24
PB-24AS	75	2" x 4" x 2"	27	36	54	63	81	90	117
PB-8ASDDivider for PB-8AS conductive plastic box									
PB-24ASDDivider for PB-24AS conductive plastic box									

Conductive Plastic Boxes: Full Depth

PART NO.	NUMBER/HT.	L X W X H	FOR DRAWER						
			NW	MP	SC	EW	HW	MW	DW
PB-1AS		3" x 3" x 1"	32	48	64	80	96	112	136
PB-2AS		3" x 3" x 1"	32	48	64	80	96	112	136
PB-3AS		3" x 6" x 1"	16	24	32	40	48	56	68
PB-4AS		6" x 6" x 1"	8	12	16	20	24	28	32
PB-5AS	75	3" x 3" x 2"	32	48	64	80	96	112	136
PB-6AS	75	3" x 6" x 2"	16	24	32	40	48	56	68
PB-7AS	75	6" x 6" x 2"	8	12	16	20	24	28	32
PB-8AS	100	3" x 6" x 3"	16	24	32	40	48	56	68
PB-9AS	100	6" x 6" x 3"	8	12	16	20	24	28	32
PB-24AS	75	2" x 4" x 2"	36	54	72	90	108	126	156

Angled Label Holders for Plastic Boxes

Fits into slot in plastic boxes. Transparent label protectors included.



Angled Label Holders for Plastic Boxes

PART NO.	FOR USE WITH
X280*	plastic boxes (red)
X280-AS	conductive plastic boxes (black)

*not for use with PB-24 box

GROOVED TRAYS

Grooved Tray Divider

1 1/8" wide x 1" high galvanized steel divider fits into slots in grooved tray to separate and label contents.

Grooved Trays

These high impact red ABS plastic trays are for individual storage of side sensitive tools such as taps and reamers. Tools are held in place by wedge-shaped grooves which prevent side-to-side movement in the drawer. In 2 parts, each part with end tongues to fit slotted partitions or drawer sidewall. Each 2-part tray is 9 units (153mm) wide x 97mm deep. Sectioned off with D-9 drawer dividers. Larger trays in the set are slotted for clip-on label holders (not included, see page 264). Grooved tray dividers (see to right) not included.



Grooved Tray Divider

PART NO.

2GTD

Grooved Trays

PART NO.	FOR MAXIMUM TOOL DIAMETER	NO. OF GROOVES
PGT-19	5/16" (8mm)	11
PGT-29	9/16" (14mm)	8
PGT-39	3/4" (20mm)	6



Slotted Grooved Trays

Trays are for storage of drills, gauges, mills, etc. Made of durable high impact polystyrene (HIPS) red plastic with end tongues so units snap together to form a continuous tray. Slotted at 9/16" increments, plastic dividers subdivide individual grooves into smaller compartments. Each 6" x 6" tray can have 2, 3, or 4 grooves. Clip-on label holders not included (see page 264). Slotted tray dividers are not included.

Slotted Grooved Trays and Dividers (each sold separately)

PART NO.	FOR MAXIMUM TOOL DIAMETER	NO. OF GROOVES	SLOTTED TRAY DIVIDERS PART NO.	AVERAGE QTY. REQUIRED PER SLOTTED TRAY
SGT-4	1 1/4" (33mm)	4	STD-4	5 dividers
SGT-3	1 3/4" (45mm)	3	STD-3	4 dividers
SGT-2	2 3/4" (70mm)	2	STD-2	3 dividers



Conductive Slotted Grooved Trays

Trays are for storage of electrostatically sensitive components and MOS semiconductor devices. Made of conductive black high impact polystyrene (HIPS). Each groove is slotted at 9/16" intervals with end tongues so units snap together to form a continuous tray. Clip-on label holders (see page 264) not included.

Conductive Slotted Grooved Trays and Dividers (each sold separately)

PART NO.	FOR MAXIMUM TOOL DIAMETER	NO. OF GROOVES	SLOTTED TRAY DIVIDERS PART NO.	AVERAGE QTY. REQUIRED PER SLOTTED TRAY
SGT-4AS	1 1/4" (33mm)	4	STD-4AS	5 dividers
SGT-3AS	1 3/4" (45mm)	3	STD-3AS	4 dividers
SGT2AS	2 3/4" (70mm)	2	STD-2AS	3 dividers

Paper Label Sheets

Perforated sheets of label paper allow printing of labels with Lista Script software that fit perfectly into the wide variety of Lista label-holding tabs and covers. One package of 18.784 drawer handle labels is included with each Lista cabinet.

Paper Label Sheets

PART NO.	LABEL SIZE	FOR USE WITH	SHEETS/PKG.	LABELS/SHEET
18.784	210mm x 22mm	all hinged drawer handle covers	5 sheets (A4 size)	30
18.785	47mm x 18mm	DLH-3 label holders	2 sheets (A4 size)	52
18.786	47mm x 12mm	X280 and X280-AS label holders DLH-2 label holders	2 sheets (A4 size)	76
18.787	27mm x 12mm	DLH-1 label holders	2 sheets (A4 size)	133
18.932	52.5mm x 18mm	self-adhesive label holders	2 sheets (A4 size)	52

OTHER ACCESSORIES

Milling Cutter Holders

Tools with center holes are put over these holders for non-slip stability in the drawer. Red high-impact plastic holders can be fastened together to any required height and are bolted to perforated drawer bottom. Nuts are included.



Milling Cutter Holders

PART NO.	FOR ARBOR-HOLE SIZE
CH-1	1/2" (12mm)
CH-2	5/8" (15.5mm)
CH-3	7/8" (21.5mm)
CH-4	1" (25mm)
CH-8	1 1/16" (26.5mm)
CH-5	1 1/4" (31mm)
CH-6	1 1/2" (37.5mm)
CH-9	1 9/16" (39.5mm)
CH-7	2" (49.5mm)

Corrugated Steel Supports

For holding arbors, punches, drifts, etc., with 17 recesses. Held with plain partition. Pressed steel sheet, electrophoretically deposited, stoved enamel. Finished in gray.



Corrugated Steel Supports

PART NO.	LENGTH
X1152	18"

Holding Pins

Galvanized steel rods with screw bottoms are bolted to perforated drawer bottom for positioning and holding irregularly shaped tools. Nuts included.



Holding Pins

PART NO.	DIAMETER	HEIGHT
HP-1	1/4" (6mm)	1" (26mm)
HP-2	1/4" (6mm)	2" (52mm)
HP-3	1/4" (6mm)	3" (77mm)

Slotted Tool Supports

These 1/16" thick, 24" long aluminum slotted carriers are perfect for storing wrenches, etc. Bottom strip is bolted to perforated drawer bottom. Fasteners included. Ordered individually.



Slotted Tool Supports

PART NO.	HEIGHT	SLOT OPENING
X214	1 1/16" (26.5mm)	1/4" (7mm)
X36	1 1/16" (26.5mm)	3/16" (5mm)

OTHER ACCESSORIES

Arbor Holders

For horizontally storing tools larger than standard grooved trays. Supports are bolted in pairs to perforated drawer bottom. Elongated slots for fastening bolts allow precise positioning for particular tool diameter. Made of durable high impact red plastic. Fasteners included. Comes in pairs.

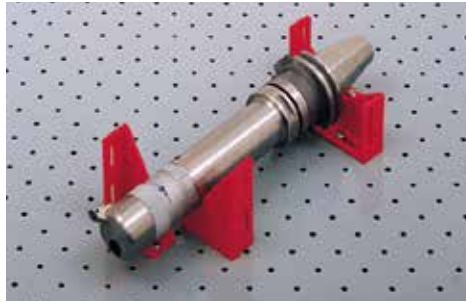

Arbor Holders

PART NO.	SIZE
AH	1" W x 3" D x 2" H
	25mm W x 75mm D x 50mm H

Metric Allen Key Holders

Red high impact plastic trays for sets of hex keys 1.5mm to 10mm.



Metric Allen Key Holders

PART NO.	SIZE
AKH	6" wide x 6" deep x 1" high

OTHER ACCESSORIES

File Drawer Inserts

- Fits into a 300 height drawer and converts it into a useable file drawer for either letter- or legal-sized files
- Sold as a set (2 pieces)



File Drawer Inserts

PART NO.	USE WITH	NO. PER DRAWER	ORIENTA. DRAWER
FFH19	NS, NW	1	side-to-side
FFH27	MP	1	side-to-side
	ST, ES	1	front-to-back
	HS	2	front-to-back
	MS, HT	3	front-to-back
FFH36	ST	1	side-to-side
	MP, SC, EW	1	front-to-back
	HW	2	front-to-back
	MW, DW	3	front-to-back

All NS300N-FFH, NS325N-FFH, NW300N-FFH & NW325N-FFH come with side supports for front to back letter size file storage

Plastic Angular Supports

- Pairs of supports hold files and small tools
- Twelve segments, red only



Plastic Angular Supports

PART NO.	SIZE
X1153	3 1/8" W x 17 1/2" D x 1/2" H 80mm W x 445mm D x 12mm H

Sliding Accessory Tray

- Tray fits into any 100 height or higher NW or MP Width drawer and can slide forward or back to allow access to the rest of the drawer contents
- For use with 1" high plastic boxes (PB-1, PB-2, PB-3 and PB-4)
- Plastic boxes must be ordered separately – see page 266



Sliding Accessory Tray

PART NO.	FOR USE WITH
AT19	NW width drawers
AT27	MP width drawers

DRAWER LINERS

Mesh Drawer Liners

- Non-slip polyester mesh liner protects items from shifting or sliding
- Protects drawer bottom from scratches and dents
- Liner is non-toxic, washable and treated to inhibit mold and mildew

Plastic Drawer Liners

- Plastic liners are 1/16" thick and translucent

Foam Drawer Liners

Shadowed foam drawer insert liners protect, identify and control valuable inventory. Using a 2-layer insert system, the upper blue foam liner cushions tools and components in perfectly-shaped cut-outs, while the bottom yellow rigid foam liner makes it easy to spot when a tool is missing from the drawer. Foam Drawer Liner Kits consist of the following:

- (5) sheets of 1/2" thick royal blue cross linked oil-resistant Tool Control Foam (polyethylene base, standard density 2#) with self-adhesive back
- (1) sheet of 1" thick royal blue cross linked oil-resistant Tool Control Foam (polyethylene base, standard density 2#) with self-adhesive back
- (6) sheets of 1/8" thick yellow high-density cross linked Tool Control Foam (polyethylene base, standard density 2#)
- (6) vellum sheets for tracing your tools
- (1) Exacto® knife for cutting blue foam
- (1) 18" ruler for measuring
- (1) instruction booklet

Foam Drawer Liner Kits

consist of the following:

- (5) sheets of 1/2" thick royal blue cross linked oil-resistant Tool Control Foam (polyethylene base, standard density 2#) with self-adhesive back
- (1) sheet of 1" thick royal blue cross linked oil-resistant Tool Control Foam (polyethylene base, standard density 2#) with self-adhesive back
- (6) sheets of 1/8" thick yellow high-density cross linked Tool Control Foam (polyethylene base, standard density 2#)
- (6) vellum sheets for tracing your tools
- (1) Exacto® knife for cutting blue foam
- (1) 18" ruler for measuring
- (1) instruction booklet

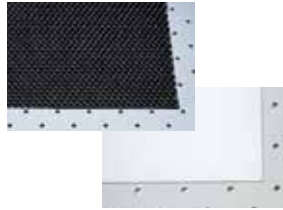

Mesh, Plastic and Foam Drawer Liners

MESH LINER PART NO.	PLASTIC LINER PART NO.	FOAM DRAWER LINER SETS		FOR USE WITH DRAWER TYPE
		1" THICK PART NO.	1/2" THICK PART NO.	
NWMDL	NWPDL	FDL-NW-1IN	FDL-NW-1/2IN	NW
MPMDL	MPPDL	FDL-MP-1IN	FDL-MP-1/2IN	MP, ST
SCMDL	SCPDL	FDL-SC-1IN	FDL-SC-1/2IN	SC
EWMDL		FDL-EW-1IN	FDL-EW-1/2IN	EW
HWMDL		FDL-HW-1IN	FDL-HW-1/2IN	HW
MWMDL	MWPDL	FDL-MW-1IN	FDL-MW-1/2IN	MW
DWMDL	DWPDL	FDL-DW-1IN	FDL-DW-1/2IN	DW
NSMDL		FDL-NS-1IN		NS
CLMDL	CLPDL	FDL-CL-1IN		CL
STMDL		FDL-ST-1IN	FDL-ST-1/2IN	ST, MP
ESMDL		FDL-ES-1IN	FDL-ES-1/2IN	ES
HSMDL	HSPDL	FDL-HS-1IN	FDL-HS-1/2IN	HS
MSMDL	MSPDL	FDL-MS-1IN		MS
HTMDL		FDL-HT-1/2IN		HT
		FDL-WBHC-1IN	FDL-WBHC-1/2IN	WBHC



Other Options

- Foam liners can be custom made to your exact specifications, including designing, cutting and labeling the inserts for your specific tool storage requirements.
- Technical grade foam inserts are available for medical, crime lab or archival storage/museum applications. **This foam does not off-gas, and can be sterilized.**
- Contact your Lista representative for details.

Foam Drawer Liner Kits

PART NO.	DIMEN.	USE WITH DR.
FDL-18X24/LOK	18" x 24"	MP, ST
FDL-24X24/LOK	24" x 24"	SC
FDL-36X18/LOK	36" x 18"	HS

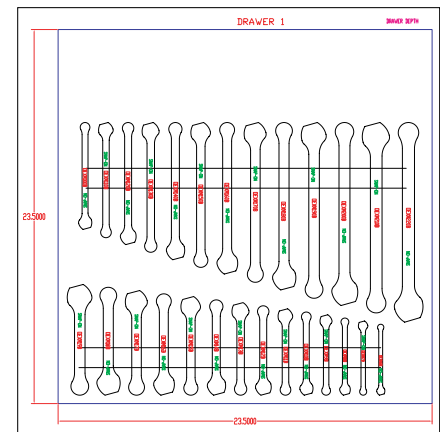

SEATING

p.274-278



SEATING SOLUTIONS

When it comes to storage components Lista® packs the toughest punch money can buy. Wouldn't it be great if there was a seating line that delivered the same level of durability, whilst providing unsurpassed comfort and functionality?

Well now there is.

Lista's new industrial seating line combines the down-and-dirty ruggedness, with hour-after-hour comfort. Built tough, for performance that lasts and is ergonomically designed to ensure proper body support. Our standard offering provide the perfect complement to any existing storage system, tailoring to specific on site job tasks and environments, custom fit to your needs with a variety of available accessories.

Please contact your local sales representative for more information on how to order seating.





MID-BACK WITH ARMS

Back Dimensions: 18 1/2" x 17 3/4"

WORKBENCH CHAIR-UPHOLSTERED

- 1 **Feature:** Options for Mid and Hi Backrest.
Benefit: Provides comfort for different size users.
- 2 **Feature:** Options for simple or deluxe seat mechanisms.
Benefit: Simple height adjustments to seat tilt.
- 3 **Feature:** Options for armrests.
Benefit: Designed for assembly to provide arm support.

Accessories: Arms, Casters

Materials: Mid-Back chairs available in both fabric and vinyl.

Deluxe seating option shown here.

Casters not included in base chair option. Armrests and casters not included in base chair option.



HIGH-BACK WITH ARMS

18 1/2" x 21 1/4"

DELUXE INDUSTRIAL CHAIR

Height Range: 20" - 37"
Seat Dimensions: 18 1/2" x 18 1/2"
Back Dimensions: 15 1/2" x 15 1/2"

Feature: Molded polyurethane seat and backrests.

Benefit: Inhibits punctures, tears and the absorption of moisture.

PRODUCTION CHAIR

Height Range: 22" - 32"
Seat Dimensions: 18 1/2" x 18 1/2"
Back Dimensions: 15 1/2" x 15 1/2"

Feature: Ergonomic features promotes increased productivity in the workplace.

Benefit: Promotes better circulation, reduces jarring to spinal vertebra and relieves tension.

ASSEMBLY

Height Range: 22" - 32"
Seat Dimensions: 18 1/2" x 16 1/2"
Back Dimensions: 17" x 12"

Feature: Easy to move in workplace with ergonomic grip in the back.

Benefit: Flexibility in workspace.



DELUXE ESD CHAIR

Height Range: 22" - 30"
 Seat Dimensions: 18 1/2" x 18 1/2"
 Back Dimensions: 16 1/2" x 15 1/2"

Feature: Closed loop ESD components designed to discharge into grounded floor.

Benefit: No drag chain needed which can fall off in a shift.

NOTE: Armrests come standard.



ESD WORKBENCH

Height Range: 22" - 30"
 Seat Dimensions: 18 1/2" x 18 1/2"
 Back Dimensions: 16 1/2" x 15 1/2"

Feature: Chrome plated steel base w/ 5 non marking glides.

Benefit: Stable at high heights and designed to not damage coated floors.



SIT STAND STOOL

Height Range: 24"-34"
 Seat Dimensions: 14" x 8"

Feature: 22" - 32" Easy to adjust Seat Height with gravity seat locking system.

Benefit: Positions worker at the appropriate height while seat locks automatically.



SIT-STAND

Height Range: 24" - 34"
 Seat Dimensions: 13" x 19"
 Back Dimensions: 10 3/4" x 15.3/4"

Feature: Inclined lift suspension.

Benefit: Positions worker forward while sitting.



TROLLEY

Height Range: 15 1/2" - 20 1/2"
 Seat Dimensions: 13" Dia.

Feature: 2 part removable tray for small parts and tools.

Benefit: Convenient storage for easy access while in workspace.



MULTI-PURPOSE STOOL

Height Range: 19" - 27"
 Seat Dimensions: 13" Dia.

Feature: "Any Where Release" Round ring seat control.

Benefit: Easy seat adjustment without locating 1 lever.

NOTE: Multi-purpose stool does not come with casters



OFFICE/PRODUCTION

Height Range: 19" - 22"
 Seat Dimensions: 22" x 20"
 Back Dimensions: 21" x 20"

Feature: 500lb Seating Capacity (with purchase of caster accessory) exceeds testing require.

Benefit: Designed for Big and Tall applications.

NOTE: Armrests and carpet casters come standard.



LAB CHAIR

Height Range: 21" - 28"
 Seat Dimensions: 18" x 16 1/2"
 Back Dimensions: 17" x 15"

Feature: Antimicrobial vinyl seat and back.

Benefit: Suppresses the growth of microorganisms and limits the transmission of harmful microbes.



LAB STOOL

Height Range: 17" - 22"
 Seat Dimensions: 14" Round
 Back Dimensions: 12" x 6"

Feature: 3.5" thick vinyl seat with dual bar backrest.

Benefit: Designed for sitting for long periods.



ROUND RING CONTROL LAB STOOL

Height Range: 18" - 24"
 Seat Dimensions: 14" Round
 Back Dimensions: NA

Feature: Vinyl and chrome components designed for lab environments.

Benefit: Easy to wipe down.



LAB SIT STAND

Height Range: 26" - 35"
 Seat Dimensions: 12 3/4" x 3.5"
 Back Dimensions: NA

Feature: Inclined lift suspension.

Benefit: Positions worker forward while sitting.



HOW TO ORDER

How to order seating solutions

1. Select base chair seating option.
2. Find part number based on description.

See chart below.

3. ■ Select Accessories

- Armrest Accessory** = A
- Hard Floor Caster Accessory** = C1
- Carpet Caster Accessory** = C2
- Both Accessories** = A/C1 or C2

EXAMPLE: to order a Deluxe Industrial Chair with both armrests and hard floor casters, the part number would be **CHR-DLXIND/A/C1**.

SEATING ACCESSORIES



Casters



Arms

* Casters available in both hard floor or carpet option pending chair.

* Armrests to be purchased separately unless otherwise noted.

NOTE: All chairs come standard in black unless otherwise shown.



SEATING SOLUTIONS PART NUMBERS

DESCRIPTION	PART NUMBER	W/ARMREST	W/CASTER	W/CASTER 2	W/ ALL ACCESSORIES	W/ ALL ACCESSORIES
Deluxe Industrial Chair	CHR-DLXIND	CHR-DLXIND/A	CHR-DLXIND/C1	-	CHR-DLXIND/A/C1	-
Production Chair	CHR-PRODN	CHR-PRODN/A	CHR-PRODN/C1	-	CHR-PRODN/A/C1	-
Assembly	CHR-WB	CHR-WB/A	CHR-WB/C1	-	CHR-WB/A/C1	-
Workbench Chair Upholstered						
Mid-Back	CHR-WB-MB	CHR-WB-MB/A	CHR-WB-MB/C1	CHR-WB-MB/C2	CHR-WB-MB/A/C1	CHR-WB-MB/A/C2
High-Back	CHR-WB-HB	CHR-WB-HB/A	CHR-WB-HB/C1	CHR-WB-HB/C2	CHR-WB-HB/A/C1	CHR-WB-HB/A/C2
Mid-Back w/ Arms	CHR-WB-MBDLX	CHR-WB-MBDLX/A	CHR-WB-MBDLX/C1	CHR-WB-MBDLX/C2	CHR-WB-MBDLX/A/C1	CHR-WB-MBDLX/A/C2
High-Back w/ Arms	CHR-WB-HBDLX	CHR-WB-HBDLX/A	CHR-WB-HBDLX/C1	CHR-WB-HBDLX/C2	CHR-WB-HBDLX/A/C1	CHR-WB-HBDLX/A/C2
Vinal Mid-Back	CHR-WB-VMB	CHR-WB-VMB/A	CHR-WB-VMB/C1	CHR-WB-VMB/C2	CHR-WB-VMB/A/C1	CHR-WB-VMB/A/C2
Office/Production	CHR-PRODN-T	Comes standard	CHR-PRODN-T/C1	Comes standard	-	Comes standard
Trolley	STL-TROLLEY	-	-	-	-	-
Multi-Purpose Stool	STL-MPURP	-	STL-MPURP/C1	-	-	-
Deluxe ESD Chair	CHR-WB-ESDDLX	Comes standard	CHR-WB-ESDDLX/C1	-	-	-
ESD Workbench	CHR-WB-ESD	-	CHR-WB-ESD/C1	-	-	-
Sit-Stand	STL-SITSTAND	-	-	-	-	-
Sit Stand Stool	STL-SITSTAND-B	-	-	-	-	-
Lab Chair	CHR-WKBNCH-LAB	-	-	-	-	-
Lab Stool	STL-SITBACK-LAB	-	-	-	-	-
Round Ring Control Lab Stool	STL-RNDRING-LAB	-	-	-	-	-
Lab Sit Stand	STL-SITSTAND-LAB	-	-	-	-	-



SEATING





PAINT FINISHES

Lista Colors



CODE COLOR
BE Beige



CODE COLOR
BB* Bright Blue

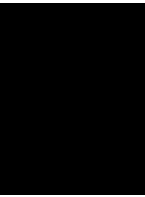

CODE COLOR
BK* Black



CODE COLOR
CB Classic Blue



CODE COLOR
GR Dark Gray



CODE COLOR
GG Green



CODE COLOR
NR Red



CODE COLOR
FW White

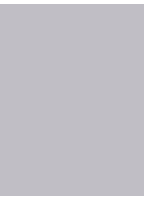

CODE COLOR
LG* Light Gray



CODE COLOR
SN Sand

Tech Series Toolbox Only Colors



CODE COLOR
293 Blaze Blue



CODE COLOR
5003 Dusk Blue



CODE COLOR
BKG Black



CODE COLOR
NRG Red



CODE COLOR
12179 Yellow

* Tech Series Toolbox paint colors have a premium gloss finish.

Arlink Colors

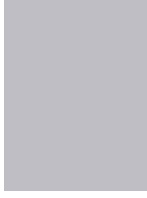

CODE COLOR
LG* Light Gray



CODE COLOR
SN Sand



CODE COLOR
BB Bright Blue



CODE COLOR
BL Black

* Available with ESD properties. To specify ESD paint, add prefix "ESD" to paint part number. For ESD paint specifications, contact Lista Customer Service. **ESD paint not available for Arlink® 8000 products.**

Color differences exist between color samples and actual finishes. Please contact your Lista representative for accurate color matching. Custom colors are available and will be quoted on request.



For a personalized storage consultation,
please contact:

Industrial Ergonomics

612-532-6774

jeff@Industrial-Ergonomics.com



StanleyBlack&Decker