

**YOU STAND.
WE DELIVER.**



RHINO
ANTI-FATIGUE MATS



C A T A L O G # 3 9

STAND-UP PERFORMAN

RHINO MILESTONES

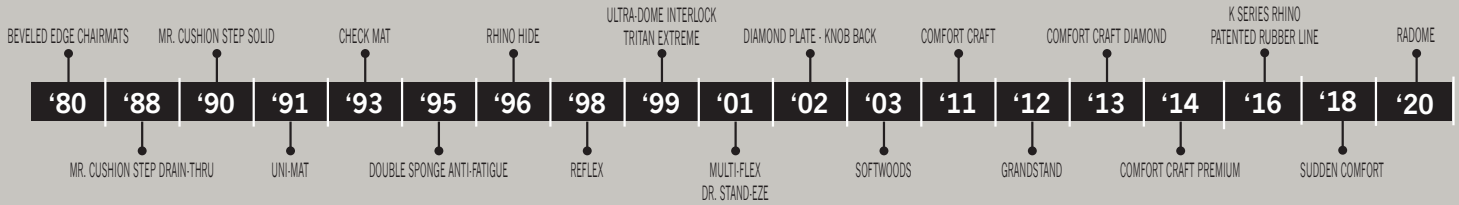

Rhino Mat Manufacturing was founded by Randy Allen in 1978 as an alternative to out-sourced, mass-produced mediocrity. It was a stubborn, hard charging notion that has never changed. Little wonder that Randy chose a Rhino as his brand's symbol. Today, Randy operates Rhino with his son Brock Allen who shares this vision for a product of high quality, at a fair price, with unrelenting innovation.

It's all about being an advocate for the salon industry stylist. To provide them and their employers with high-performance salon mats that improve health, reduce fatigue and create productivity gains.

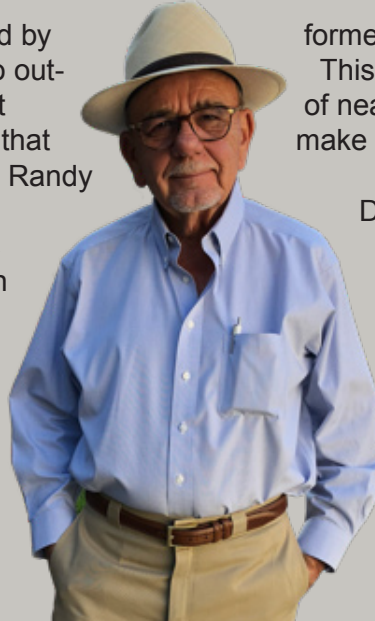

formed the way salon mats were engineered. This innovation still serves as the foundation of nearly every performance enhancement we make to the line.

Double-sponge engineering ensures the standing salon worker feels less fatigue, contributes greater productivity and fewer standing related health issues.

But that's not all. Our innovative anti-fatigue mats have actually been shown to effectively lower a salon's health care expenses and insurance claims, making salons more profitable while improving morale.

NON-STOP INNOVATION

Our success has been built of innovation. By taking the anti-fatigue properties of traditional single-sponge matting and increasing it two-fold, we knew we could improve the health and productivity of the stylist. Our invention of double-sponge matting propelled us into the forefront of our industry and tran

Rhino's unswerving dedication to state-of-the-art ergonomics means constant innovation.



Ergonomics is the scientific study of how to reduce strain and injuries associated with human posture and body movement. By using ergonomic science to our advantage we have been able to engineer better and better products to meet specific standing environments. The innovation never stops.



CE. STANDOUT QUALITY.

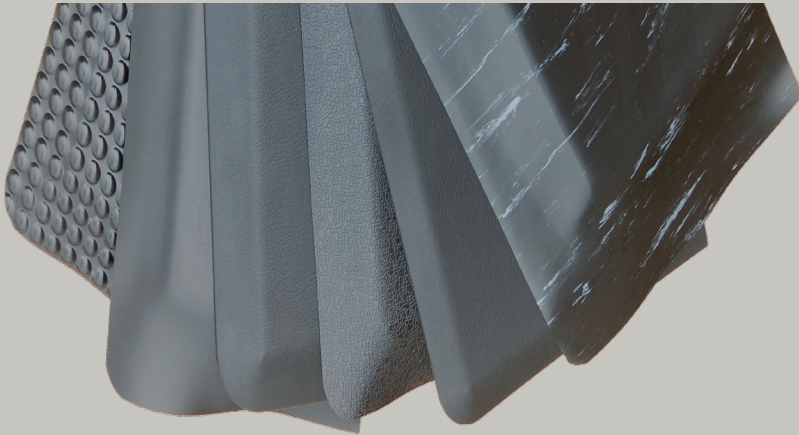

PERFORMANCE-BASED PRODUCTS

This history of innovation continues to produce new mats to meet the unique needs of a wide variety of tastes. From our basic Black/White Marbleized mat with its single sponge anti-fatigue mats to our innovative Comfort Craft mat designed to address the unique needs of our country's aging work force, every mat serves a special purpose.

Our Multi-Flex anti-fatigue mats have ergonomic channels inside the foam to encourage subtle leg and foot movements that promote blood flow thereby reducing fatigue. Our Reflex mat allows for torque-free movement reducing stress on knees, ankles and hips. This performance innovation is something we call "Pivot Point Ease.™"

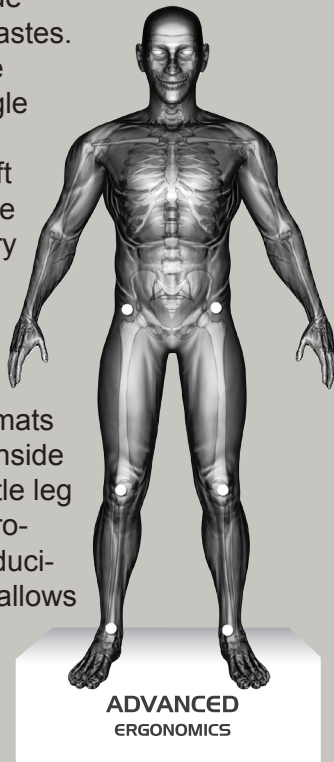

And that's just the beginning. Rhino has engineered mats for the unique needs of the Beauty and Barber industries. There is no standing work situation, that we have not develop a mat ideally suited to ensure the salon stylist better health, less fatigue and greater output.



AMERICAN MADE

For 30+ years, Rhino Mats have resisted the growing trend of overseas out-sourcing. Our commitment to U.S.A. sourced and manufactured mats continues to ensure the highest quality, performance, and ready availability for our ever-growing line.



CUSTOMIZED ATTENTION

Rhino Mats is more than a manufacturer of high-quality, high-performance mats. We are anti-fatigue mat experts. And that expertise is available to every one of our customers. Our sales force can advise you on which mat will be the most effective for each area of your facility and for your budget. In addition, our team includes custom mat specialists who can help you

plan and configure custom-shaped matting to fit your specific needs. Little wonder that more and more companies are looking to us with



HELPFUL
CALL SUPPORT

large mat big volume orders for major installations. Our team works hard to make sure every installation goes smoothly. We sweat the details so you never have to.

To learn more visit us at rhino-mats.com

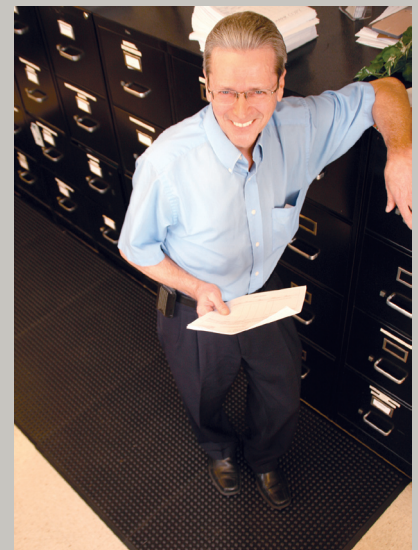

RHINO
ANTI-FATIGUE MATS

YOU STAND. WE DELIVER.



PRODUCTS

DRAIN THRU MATS

Sudden Comfort	1
K-Series Drain-Thru.....	2-3
K-Series Kitchen Drain-Thru.....	4-5
K-Series Red Meter Mat.....	6
K-Series Meter Mat Drain-Thru	7
K-series Comfort Tract	8
K-series Comfort Tract Red.....	9
Drain-X Diamond.....	10
Hex-O-Lite	11
Multi-Mat.....	12
Pro-TEX.....	13
Traktor Mat.....	14
K-Series Safety Tract	16

ANTI-FATIGUE MATS

Industrial Smooth.....	17
Reflex	18-19
Diamond Plate	20
Diamond Plate with Chevron Edges.....	21
Diamond Plate Brite.....	22
Diamond Plate/Knob Back.....	23
Diamond Plate with No Slip	24
Rhino Hide.....	25
Marbleized Tile Top	26
Marbleized with No Slip.....	27
Softwoods.....	28
Tuff Plush	29
Multi-Flex	30
HDT Anti-Fatigue.....	31
Comfort Craft.....	32
Radome	33
GrandStand	34
Comfort Craft Diamond.....	35
Diamond-Tred.....	36
Dura Step	37
Comfort Step Textured	38
Comfort Step Safety	39
Ultra-Dome Workstation	40
Tritan Ultra-Dome Rolls.....	41

HIGH IMPACT MATS

K-series Solid Cushion	42
Tritan M-Pact.....	43

ESD ANTI-FATIGUE

Reflex Conductive	44
Conductive Diamond	45
Conductive Smooth	46
Comfort Step ESD.....	47

ESD RUNNERS

Conductive Smooth	47
Conductive Diamond	47

DIELECTRIC SWITCHBOARD

Dual Purpose Dielectric Anti-fatigue.....	48
ASTM Switchboard (Corr. & Diamond).....	49
Mil Spec Smooth Top Switchboard	50
Mil Spec Diamond Switchboard.....	50

RUNNERS

Easy Kleen Runner.....	51
Easy Kleen Spike	51
Diamond Plate	51
Pyramid Runner.....	51
Corrugated Runner.....	52
Tritan Perma Walk.....	15

COMFORT CRAFT MATS

Sonora	53
Housewares Mat.....	54-55
Doctor Stand-Eze	56
RX Doctor's Mat	57
RX Fall Mat.....	58

DISINFECTANT SYSTEMS

Simple Solution.....	59
Foot Wash	60

ENTRANCE/SCRAPER MATS

Tritan Finger Tip	61
Tritan Ultra Scrape	62

CARPET MATS

Town N Country.....	63
Opus	63
Crosshatch	64
Poly-Olefin	64
Brush-Rib.....	65

STAIR TREADS

Diamond Stair Tread	66
Bar Stair Tread	67

DOCK BUMP. & WHEEL CHOCKS

Dock Bumpers	68-71
Wheel Chocks	71

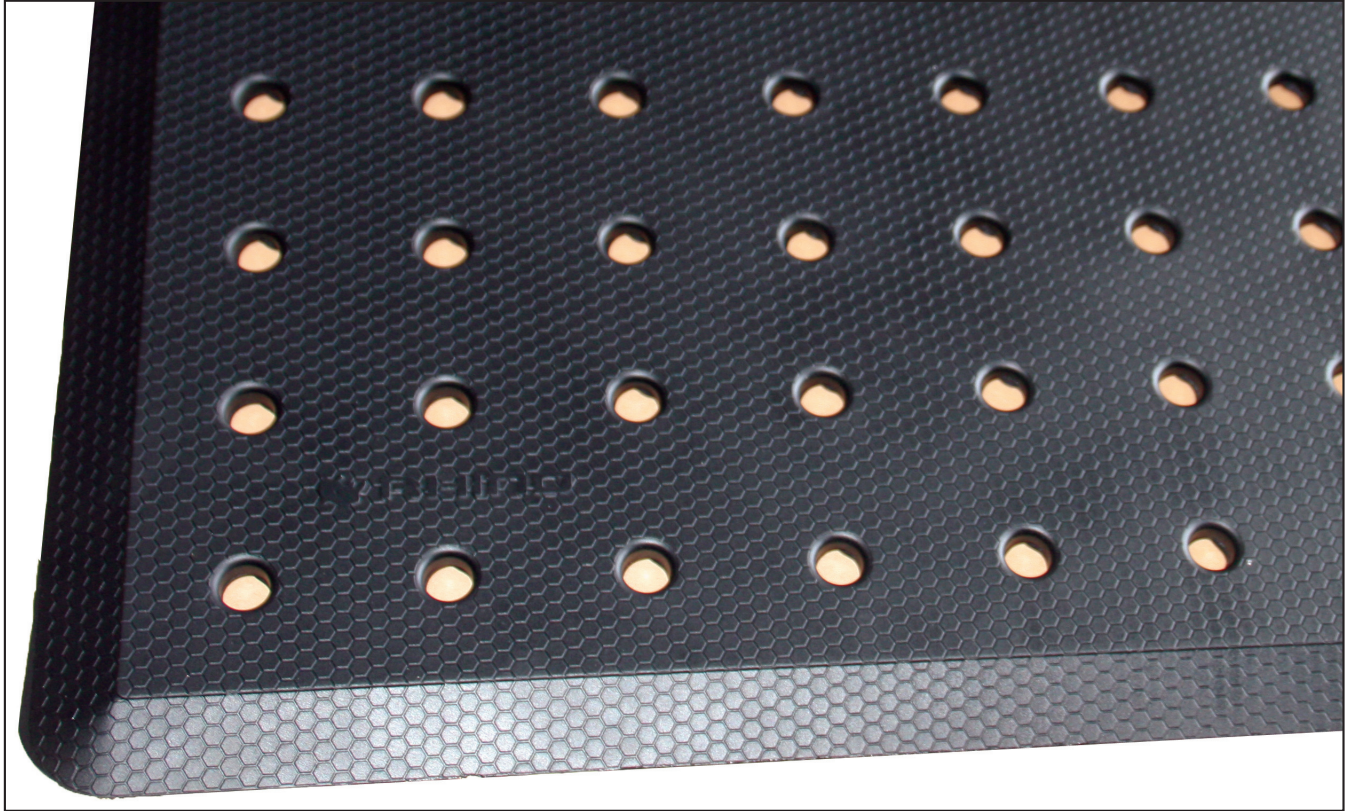

SUDDEN COMFORT

- Sudden Comfort has a faster-adapting support with a slightly springy feel. The near perfect underfoot contour offers premium ergonomics for those who need more than a rubber mat and a game changer when adapting to an aging workforce.
- A revolutionary wet area drain-thru mat made of polyurethane foam, Sudden Comfort is a 3/4" thick polyurethane sponge mat encapsulated in an unbelievably tough and wear resistant 1/8" thick solid polyurethane skin.
- When it comes to standing at work, there are “no substitutions” in place for a world class anti-fatigue mat like Sudden Comfort.
- Sizes available 2'x4', 3'x3', and 3'x5', Color: Charcoal.

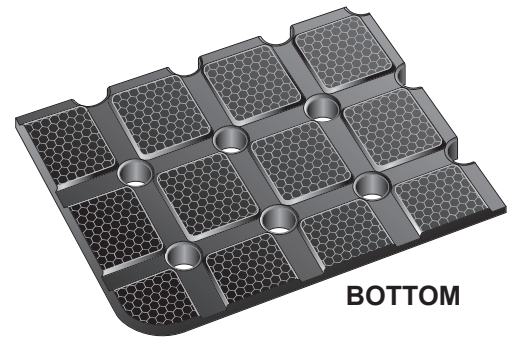
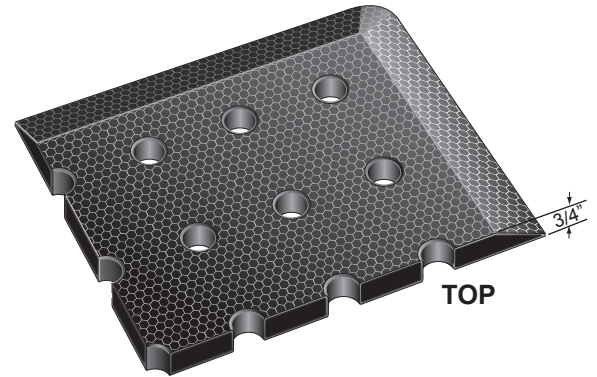

SUDDEN COMFORT 3/4"		
Stock No.	Size	Weight Ea.
SC-2448	2' x 4'	9.0 lbs.
SC-3636	3' x 3'	10.2 lbs.
SC-3660	3' x 5'	17.0 lbs.

Color: Charcoal Only. 3/4" Thick.





K-SERIES DRAIN-THRU GREASE-RESISTANT Mats

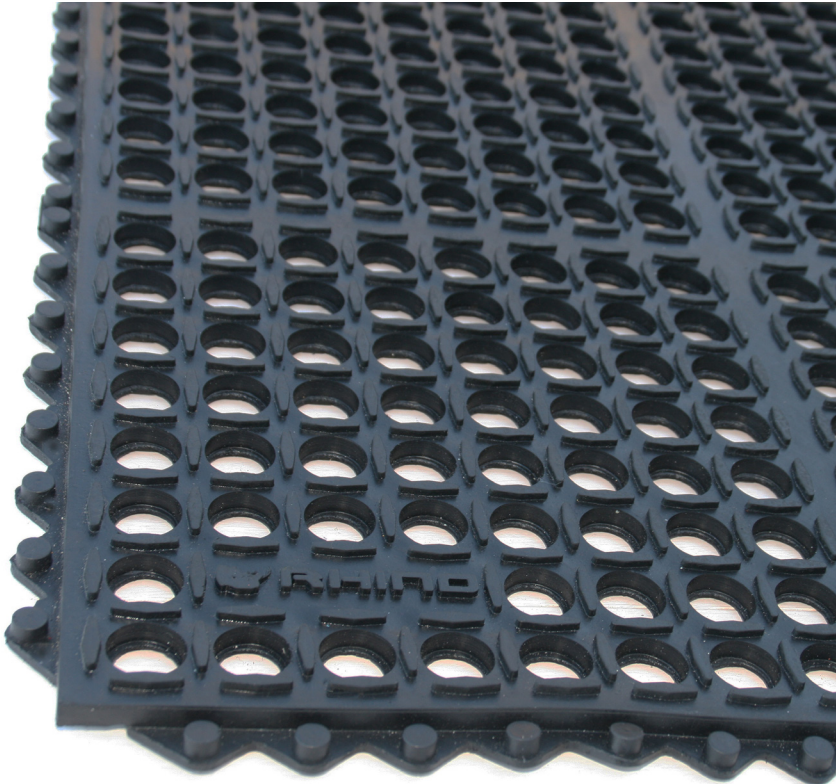

K-SERIES DRAIN-THRU MAT

- The K-Series mats are manufactured in 3 sizes, 3' x 3', 3'x4', and 3' x 5' that will lock together to create virtually any size or configuration needed.
- The K-Series high performance design offers "best in class" anti-fatigue characteristics for commercial work stations.
- The K-Series molded cross bar surface assures safe footing while the multi-bar underside adds to comfort while enhancing drainage and cleanliness.
- The K-Series is 7/10" thick. Color: Black, with built in connectors on all sides. Optional attachable bevel strips are available in Black or SafetyYellow.

K-3 SERIES DRAIN-THRU

Stock No.	Description	App. Wt.
K3-3636B	36" x 36" mat	17 lbs.
K-36M	36" bevel strip male black	1.5 lbs.
K-36MY	36" bevel strip male yellow	1.5 lbs.
K-36F	36" bevel strip female black	1.5 lbs.
K-36FY	36" bevel strip female yellow	1.5 lbs.
K-40M	40" corner bevel male black	1.8 lbs.
K-40MY	40" corner bevel strip male yellow	1.8 lbs.
K-40F	40" corn. bevel strip female black	1.8 lbs.
K-40FY	40" corn. bevel strip female yellow	1.8 lbs.

Colors: Black mats, Black or Yellow bevels. Sold separately or in Kits with bevels. Thickness: 7/10"

K-4 SERIES DRAIN-THRU

Stock No.	Description	App. Wt.
K4-3648B	36" x 48" mat	20 lbs.
K-48M	48" bevel strip male black	2.1 lbs.
K-48MY	48" bevel strip male yellow	2.1 lbs.
K-48F	48" bevel strip female black	2.1 lbs.
K-48FY	48" bevel strip female yellow	2.1 lbs.
K-40M	40" corner bevel male black	1.8 lbs.
K-4MFY	40" corner bevel strip male yellow	1.8 lbs.
K-40F	40" corn. bevel strip female black	1.8 lbs.
K-40FY	40" corn. bevel strip female yellow	1.8 lbs.

Colors: Black mats, Black or Yellow bevels. Sold separately or in Kits with bevels. Thickness: 7/10"

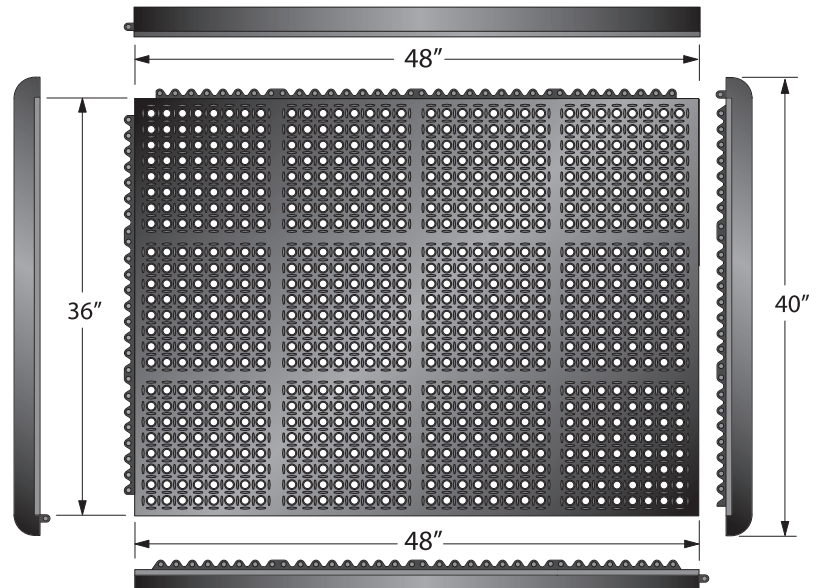
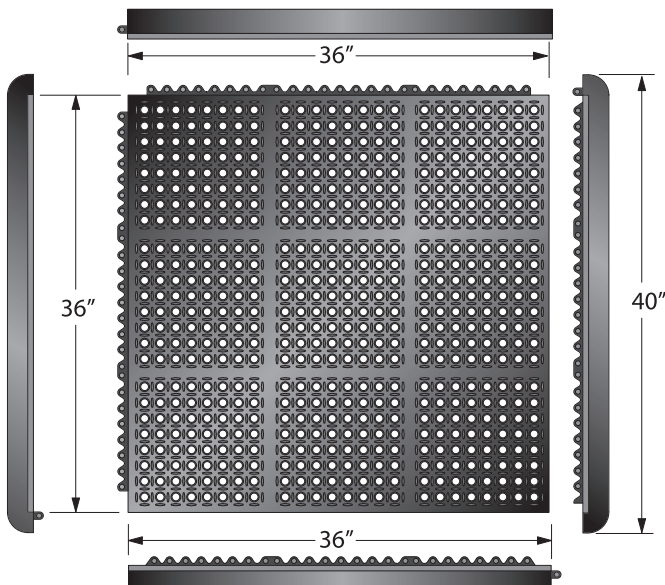



- A key ingredient of the Rhino K-Series is tree-derived rubber, harvested from the Para rubber tree. It is beneficial to the environment, it is an ecologically sustainable and renewable resource, supporting the agricultural community and contributes to the maintenance of the global carbon balance in the atmosphere.
- Natural rubber is nature's contribution to the elastomer field and offers the advantages of high resilience, high tensile and tear properties, and good flexing qualities at low temperatures.

K-5 SERIES DRAIN-THRU

Stock No.	Description	App. Wt.
K5-3660B	36" x 60" mat	25 lbs.
K-60M	60" bevel strip male black	2.6 lbs.
K-60MY	60" bevel strip male yellow	2.6 lbs.
K-60F	60" bevel strip female black	2.6 lbs.
K-60FY	60" bevel strip female yellow	2.6 lbs.
K-40M	40" corner bevel male black	1.8 lbs.
K-40MY	40" corner bevel strip male yellow	1.8 lbs.
K-40F	40" corn. bevel strip female black	1.8 lbs.
K-40FY	40" corn. bevel strip female yellow	1.8 lbs.

Colors: Black mats, Black or Yellow bevels. Sold separately or in Kits with bevels. Thickness: 7/10"

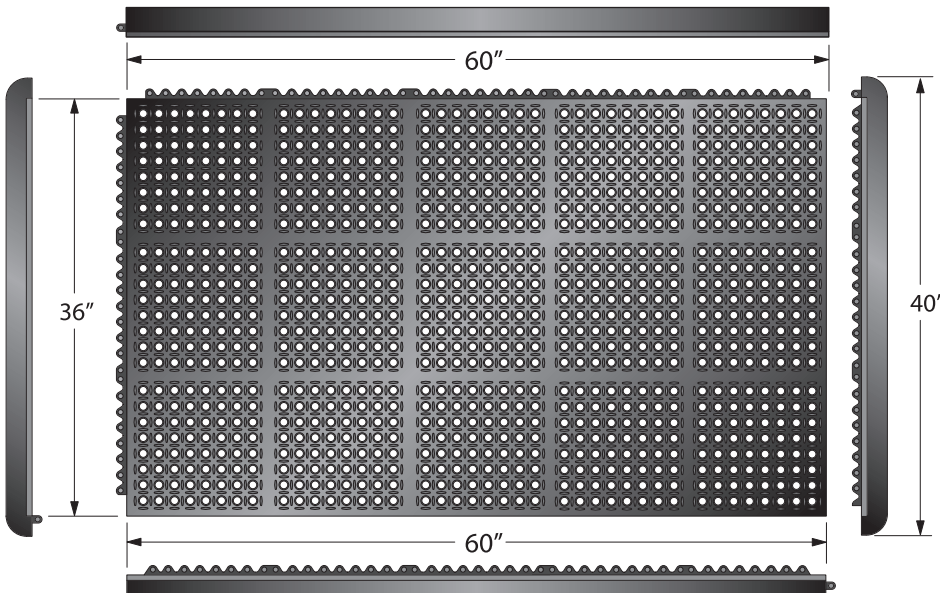
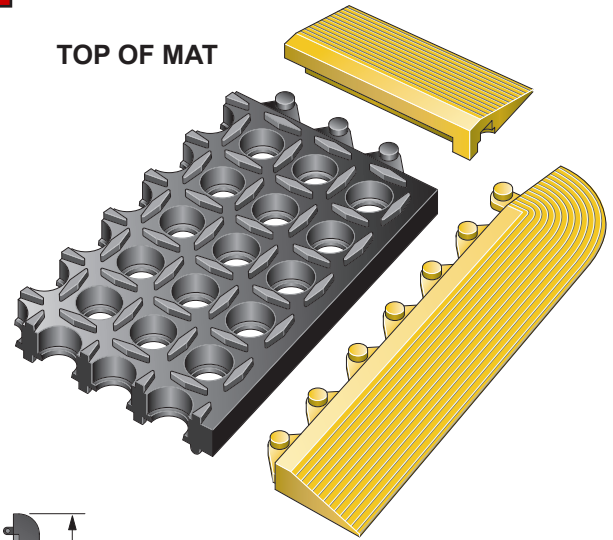

BOTTOM OF MAT

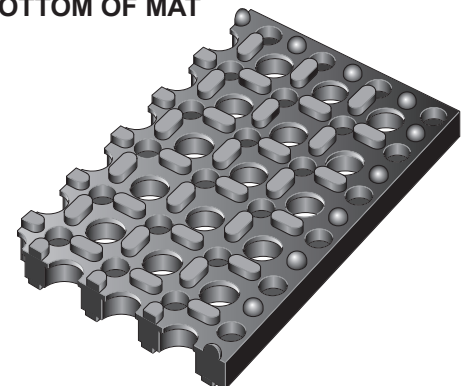



K-SERIES DRAIN-THRU Mats - Grease-Proof Terra Cotta

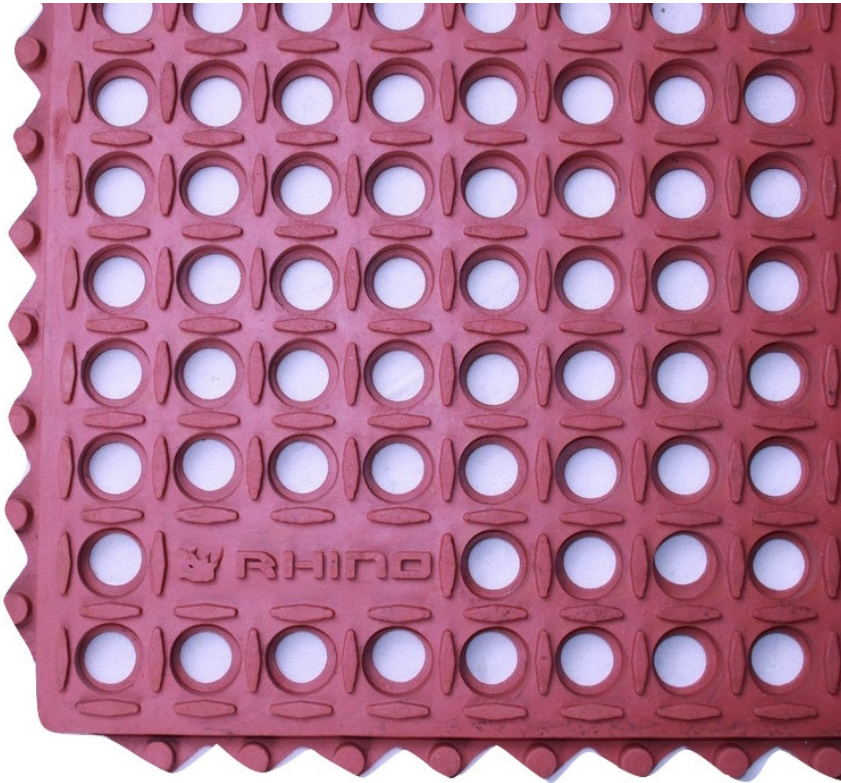

K-SERIES KITCHEN DRAIN-THRU

- K-Series Kitchen mats are manufactured in 3 sizes, 3'X3', 3'X4' and 3'X5' that will lock together to create virtually size or configuration needed.
- The K-Series high performance design offers “best in class” anti-fatigue characteristics for food service and commercial work stations.
- The K-Series molded cross bar surface assures safe footing while the multi-bar underside adds comfort, while enhancing drainage and cleanliness
- Nitrile polymer combined with tree rubber, gives you a mat that stands up to hot oil, fuel and acids.
- The K-Series is 7/10” thick. Color: Terra Cotta, with built in connectors on all sides, optional attachable bevel strips are available in matching color.

K-3 SERIES KITCHEN DRAIN-THRU

Stock No.	Description	App. Wt.
K3-3636-R	36" x 36" mat	17 lbs.
K-36MR	36" bevel strip male	1.5 lbs.
K-36FR	36" bevel strip female	1.5 lbs.
K-40MR	40" bevel strip male w/corner	1.8 lbs.
K-40FR	40" bevel strip female w/corner	1.8 lbs.

Colors: Terra Cotta mats and bevels. Sold separately or in Kits with bevels. Thickness: 7/10"

K-4 SERIES KITCHEN DRAIN-THRU

Stock No.	Description	App. Wt.
K4-3648-R	36" x 48" mat	20 lbs.
K-48MR	48" bevel strip male	2.1 lbs.
K-48FR	48" bevel strip female	2.1 lbs.
K-40MR	40" bevel strip male w/corner	1.8 lbs.
K-40FT	40" bevel strip female w/corner	1.8 lbs.

Colors: Terra Cotta mats and bevels. Sold separately or in Kits with bevels. Thickness: 7/10"

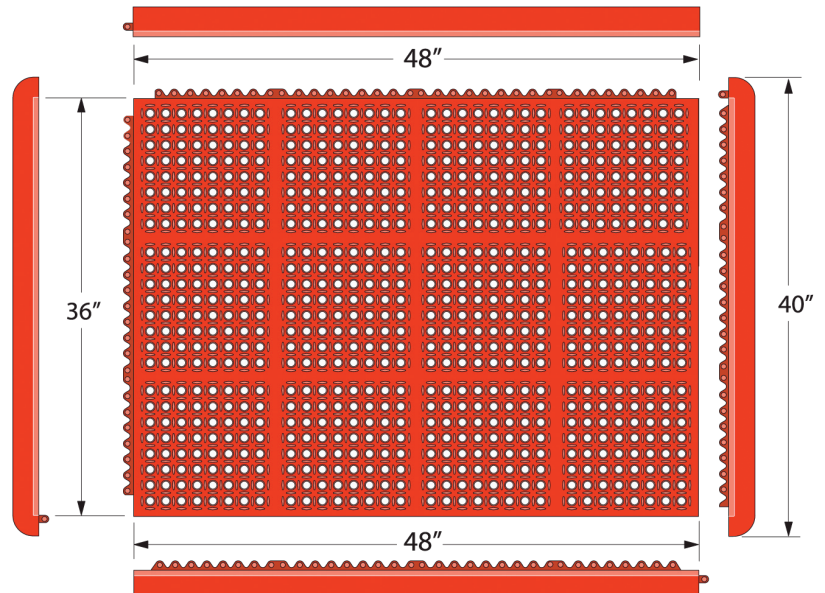
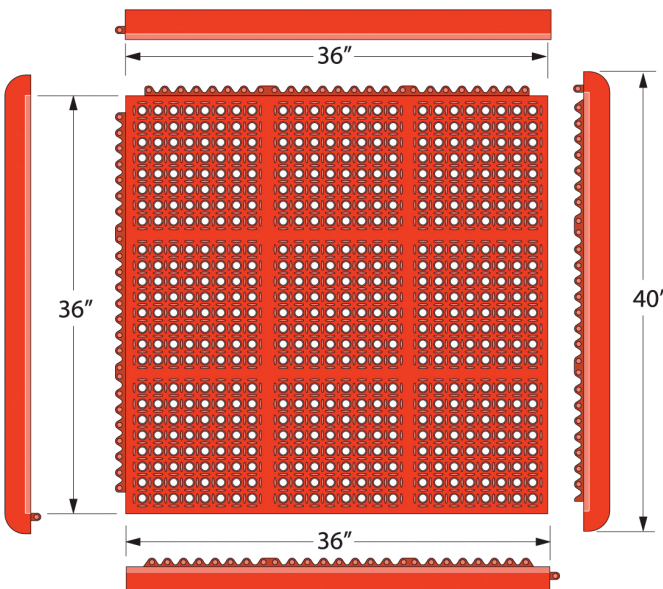

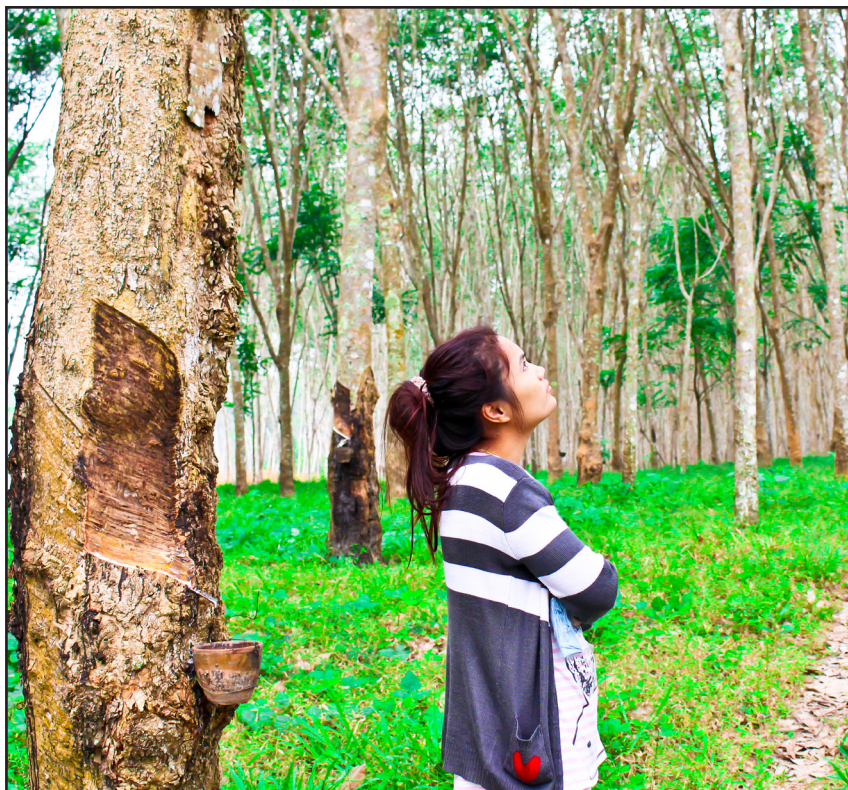

- A key ingredient of the Rhino K-Series is tree-derived rubber, harvested from the Para rubber tree. It is beneficial to the environment, it is an ecologically sustainable and renewable resource, supporting the agricultural community and contributes to the maintenance of the global carbon balance in the atmosphere.
- Natural rubber is nature's contribution to the elastomer field and offers the advantages of high resilience, high tensile and tear properties, and good flexing qualities at low temperatures.

K-5 SERIES KITCHEN DRAIN-THRU		
Stock No.	Description	App. Wt.
K5-3660-R	36" x 60" mat	25 lbs.
K-60MR	60" bevel strip male	2.6 lbs.
K-60FR	60" bevel strip female	2.6 lbs.
K-40MR	40" bevel strip male w/corner	1.8 lbs.
K-40FR	40" bevel strip female w/corner	1.8 lbs.

Colors: Terra Cotta mats and bevels. Sold separately or in Kits with bevels. Thickness: 7/10"

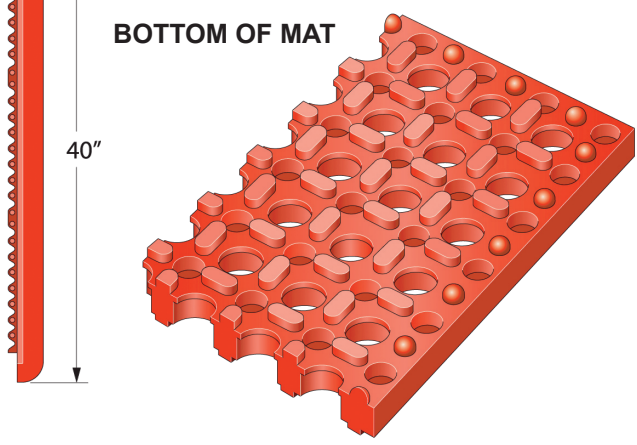
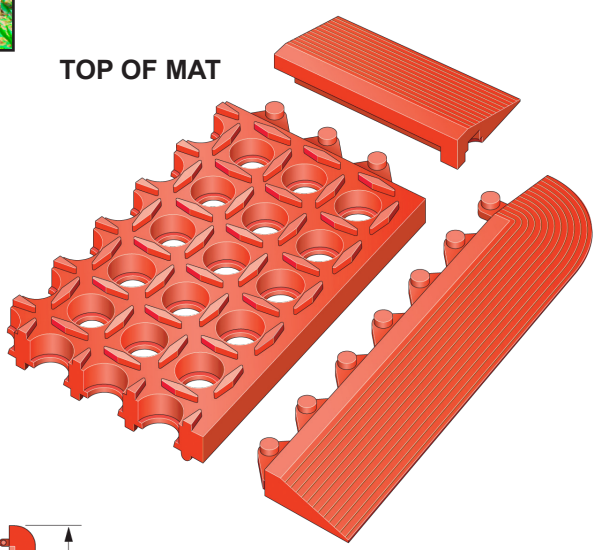
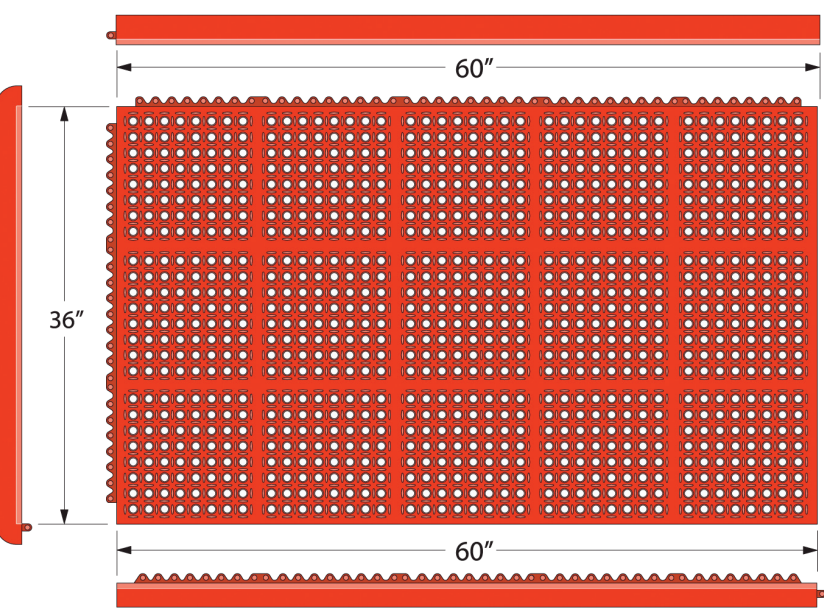



K-Series Drain-Thru Meter Mat Grease-Proof Terra Cotta

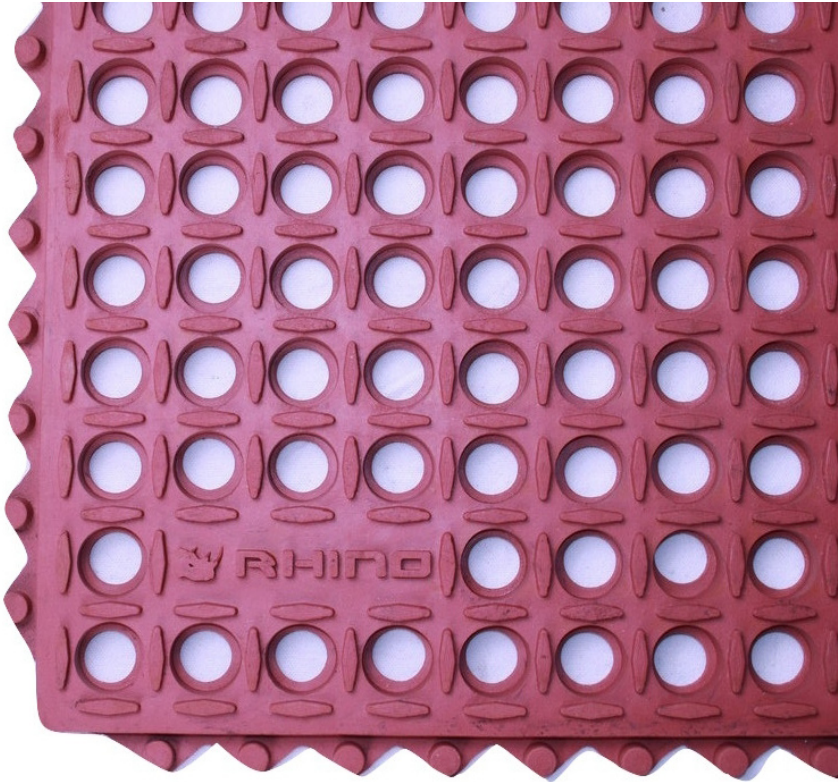

K-SERIES TERRA COTTA METER MATS

- K-Series Meter mat is manufactured in the traditional 1 meter X 1 1/2 meter size, (39"X58") which still commands a large market share in the United States and for our customers in Europe, UK, Australia and South America.
- The K-Series sectioned plug and hole inter-lock configuration in combination with our precision molding process offers you a mat with male connectors on two sides and female connectors on two sides for standard and irregular configurations, no accessory connectors are needed.
- The K-Series high performance design offers "best in class" anti-fatigue characteristics for food service and commercial work stations.
- The K-Series molded cross bar surface assures safe footing while the multi-bar underside adds comfort, while enhancing drainage and cleanliness.
- The K-Series grease proof formulation is manufactured from a combination of nitrile and tree derived rubber, harvested from the Para rubber tree. It is an ecologically sustainable and renewable resource, supporting the agricultural community and contributes to the maintenance of the global carbon balance in the atmosphere.
- Optional bevel strips available in matching Terra Cotta color.

K-9 SERIES TERRA COTTA METER MAT DRAIN

Stock No.	Description	App. Wt.
K9-3958R	39" x 58" mat	25 lbs.
K-43MR	43" Male Bevel	2.0 lbs.
K-43FR	43" Female Bevel	2.0 lbs.
K-58MR	58" Male Bevel	2.9 lbs.
K-58FR	58" Female Bevel	2.9 lbs.

Color: Terra Cotta **Thickness:** 5/8"

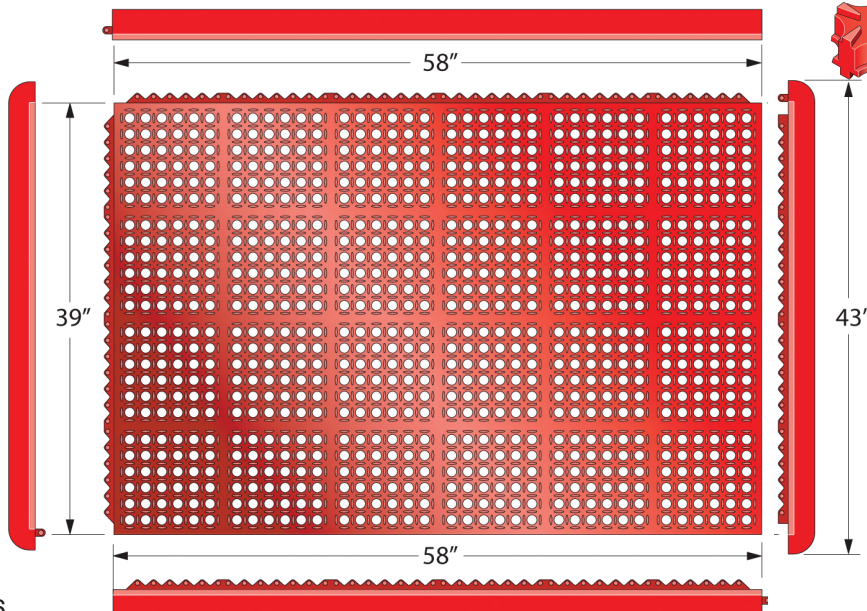
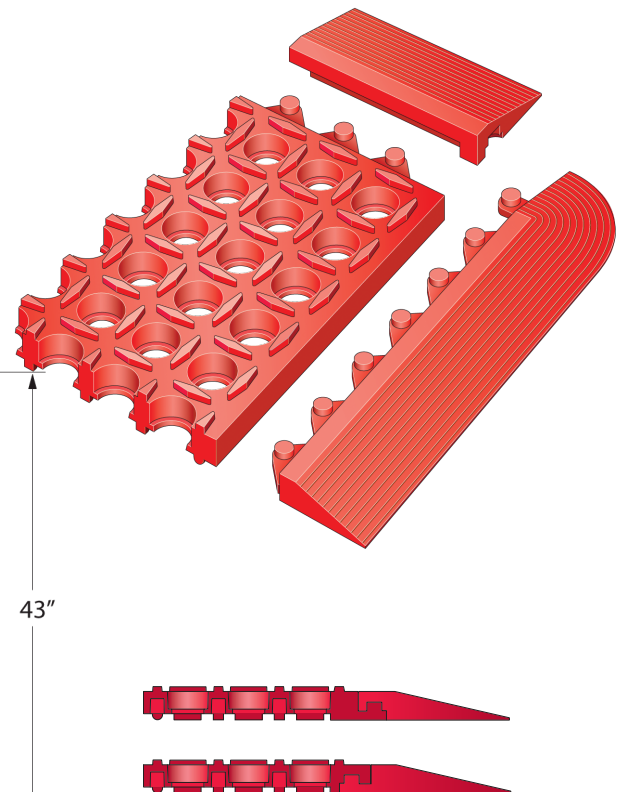

K-Series Drain-Thru Meter Mat - GREASE-RESISTANT

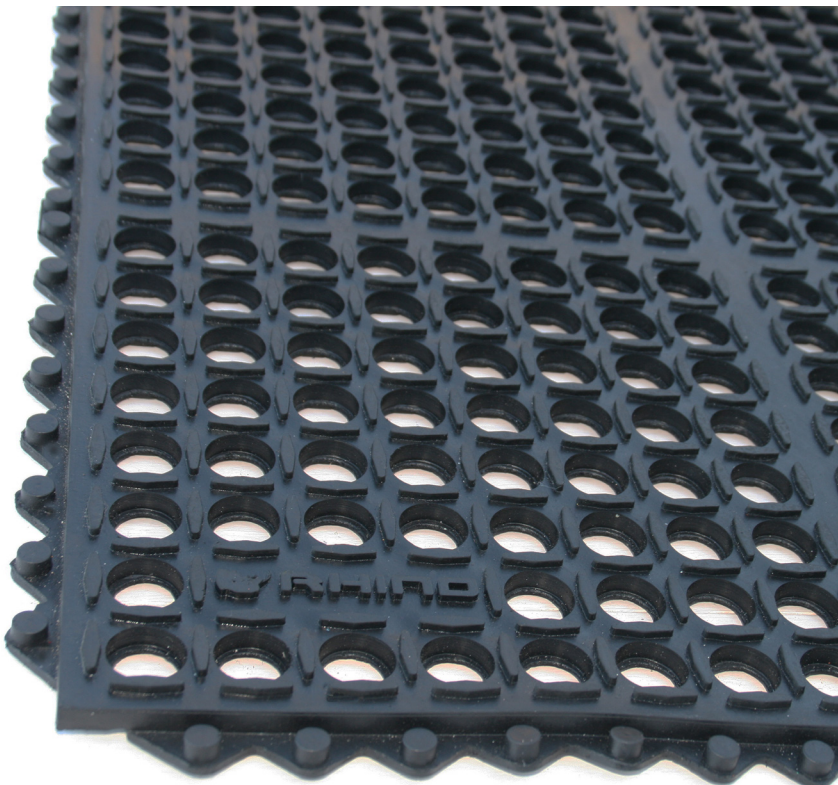

K-SERIES METER MAT DRAIN-THRU

- K-Series Meter mat is manufactured in the traditional 1 meter X 1 1/2 meter size, (39"X58") which still commands a large market share in the United States and for our customers in Europe, UK, Australia and South America.
- The K-Series sectioned plug and hole inter-lock configuration in combination with our precision molding process offers you a mat that can be cut down in size and bevels or mats reattached, creating virtually any size or configuration needed.
- The K-Series high performance design offers "best in class" anti-fatigue characteristics for commercial work stations and food service.
- The K-Series molded cross bar surface assures safe footing while the multi-bar underside adds comfort, while enhancing drainage and cleanliness.
- The K-Series grease resistant formulation is manufactured from natural tree rubber, harvested from the Para rubber tree. Natural rubber is nature's contribution to the elastomer field and offers the advantage of high resilience, high tensile and tear properties and good flexing qualities at low temperatures.
- Optional bevel strips available in Black or Safety Yellow.

K-SERIES METER MAT DRAIN-THRU

Stock No.	Description	App. Wt.
K9-3958B	39" x 58" mat	25 lbs.
K-43MB	43" Black Male Bevel	2.0 lbs.
K-43FB	43" Black Female Bevel	2.0 lbs.
K-43MY	43" Yellow Male Bevel	2.0 lbs.
K-43FY	43" Yellow Female Bevel	2.0 lbs.
K-58MB	58" Black Male Bevel	2.9 lbs.
K-58FB	58" Black Female Bevel	2.9 lbs.
K-58MY	58" Yellow Male Bevel	2.9 lbs.
K-58FY	58" Yellow Female Bevel	2.9 lbs.

Color: Black. Thickness: 5/8"

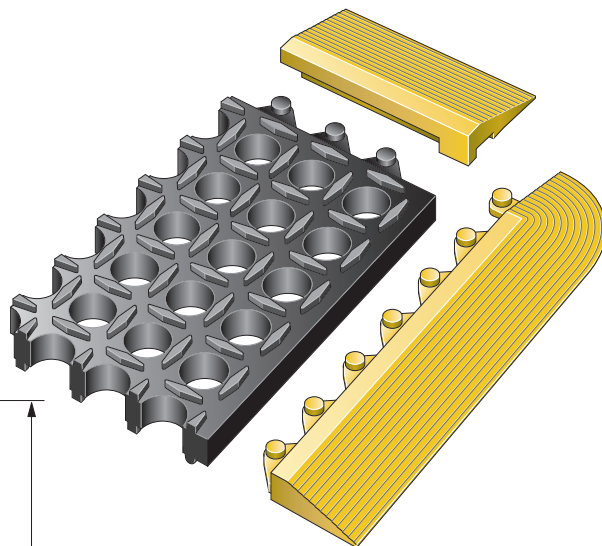
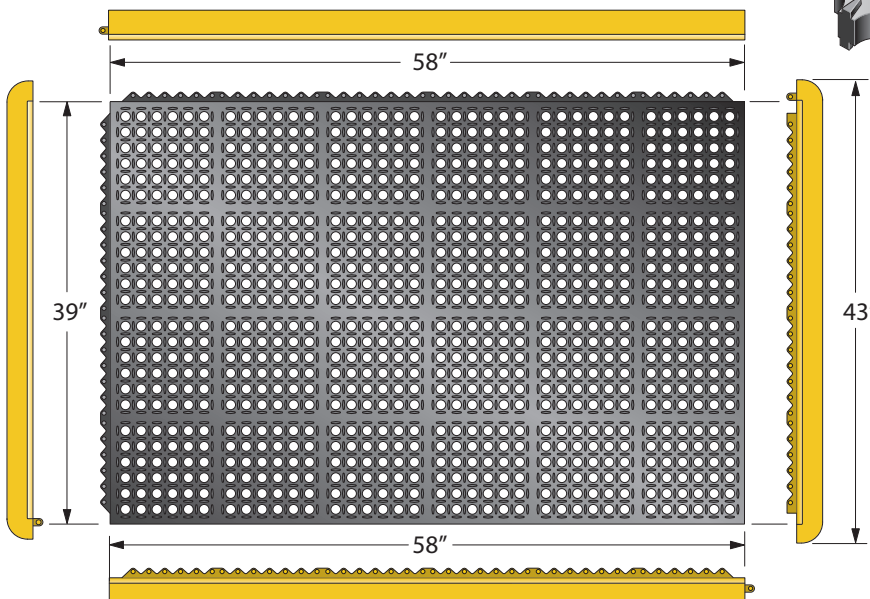



K-SERIES COMFORT TRACT® GREASE-RESISTANT



K-SERIES COMFORT TRACT

- The K-Series Comfort Tract offers light weight design, high performance, and excellent anti-fatigue characteristics in industrial and commercial work stations.
- Comfort Tract at 1/2" thick features a molded bevel edge on four sides that helps keep the mat in-place and provides easy employee and cart access.
- Molded diamond cross bar surface assures safe footing, with a thick bar underside adding to comfort while enhancing drainage and cleanliness.
- A key ingredient of the Rhino K-Series is tree-derived rubber, harvested from the Para rubber tree.
- Natural rubber is nature's contribution to the elastomer field and offers the advantages of high resilience, high tensile and tear properties, and good flexing qualities at low temperatures.
- Comfort Tract is offered in four different sizes, 3X5, 3X10, 3X15 and 3X20,



K-SERIES COMFORT TRACT		
Stock No.	Sizes	App. Wt.
CT3660	3' x 5'	17 lbs.
CT310	3' x 10'	34 lbs.
CT315	3' x 15'	51 lbs.
CT320	3' x 20'	68 lbs.

Colors: Black (Grease Resistant),
Thickness 1/2"

*3x10, 3x15, 3x20 consist of multiple mats bonded together, resulting in a slightly less overall length.

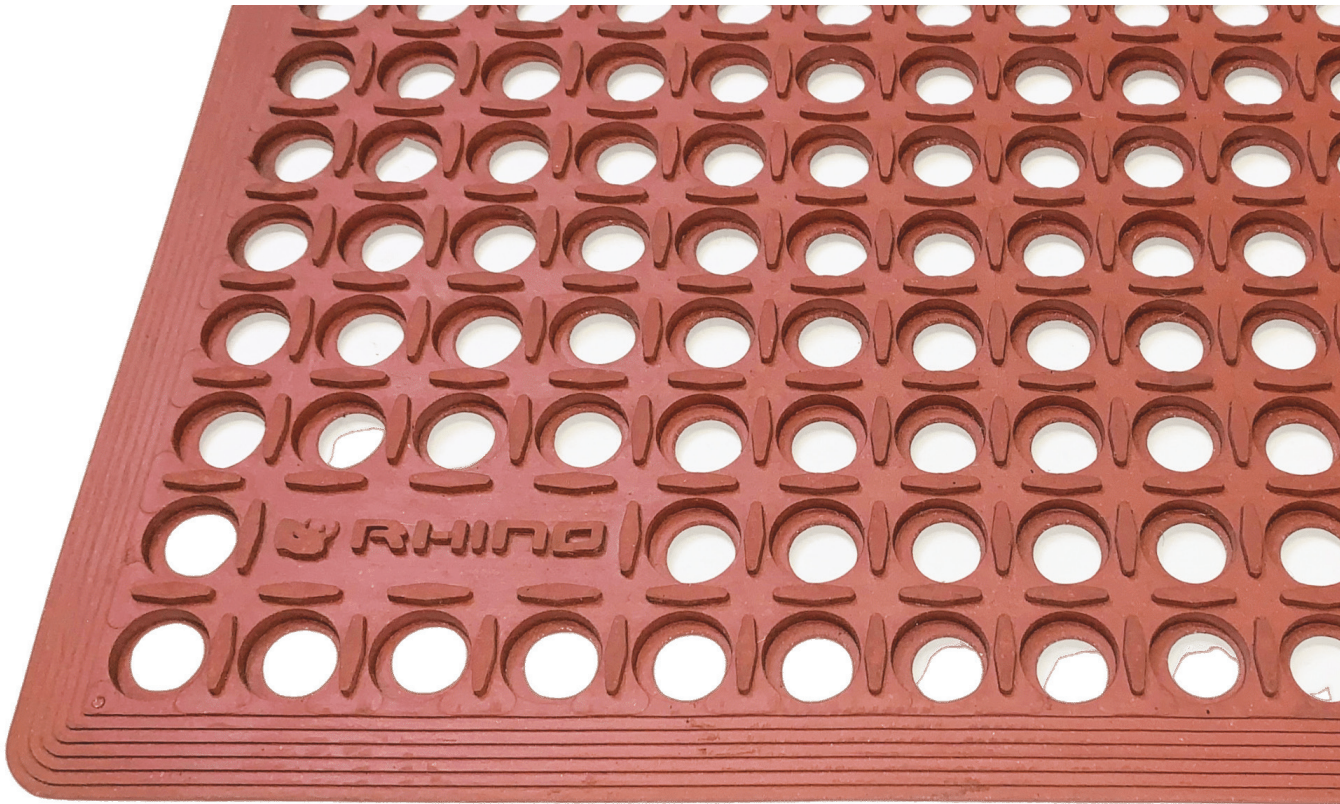

K-SERIES TERRA COTTA COMFORT TRACT

- The K-Series Comfort Tract offers light weight design, high performance, and excellent anti-fatigue characteristics in industrial and commercial work stations.
- Comfort Tract at 1/2" thick features a molded bevel edge on four sides that helps keep the mat in-place and provides easy employee and cart access.
- Molded diamond cross bar surface assures safe footing, with a thick bar underside adding to comfort while enhancing drainage and cleanliness.
- Available in grease-proof, high-nitrile terra cotta formulation, also.
- A key ingredient of the Rhino K-Series is tree-derived rubber, harvested from the Para rubber tree.
- Natural rubber is nature's contribution to the elastomer field and offers the advantages of high resilience, high tensile and tear properties, and good flexing qualities at low temperatures.
- Comfort Tract is offered in four different sizes, 3X5, 3X10, 3X15 and 3X20.

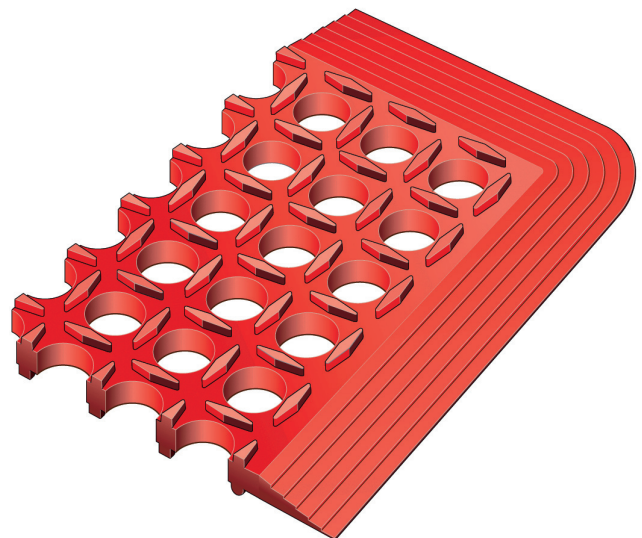

K-SERIES COMFORT TRACT

Stock No.	Sizes	App. Wt.
CT3660R	3' x 5'	17 lbs.
CT310R	3' x 10'	34 lbs.
CT315R	3' x 15'	51 lbs.
CT320R	3' x 20'	68 lbs.

Colors: Terra Cotta (Grease Proof),
Thickness 1/2"

*3x10, 3x15, 3x20 consist of multiple mats bonded together, resulting in a slightly less overall length.



DRAIN-X Diamond Drain-Thru Anti-Fatigue Mats



DRAIN-X DIAMOND DRAIN-THRU

- Drain-X is the next generation of rubber drain-thru mats, featuring a unique rectangular hole design for enhanced drainage.
- Non-direction diamond surface offers a double-tiered non-slip design with serrated diamond top surface. Beefed up connectors on four sides for large area coverage.
- Drain-X is a versatile, multi-purpose mat that is **economically priced** and sure to fit any budget.
- A key ingredient of Drain-X is tree-derived rubber, harvested from the Para rubber tree. It is beneficial to the environment, it is an ecologically sustainable and renewable resource, supporting the agricultural community and contributes to the maintenance of the global carbon balance in the atmosphere.
- Natural rubber is nature’s contribution to the elastomer field and offers the advantages of high resilience, high tensile and tear properties, and good flexing qualities at low temperatures.
- Offered in Grease-Resistant Black and Grease-Proof Terra Cotta that stands up to hot oil, machine cutting fluids and similar liquids found in industrial and commercial environments. Available in a 3x3 size.

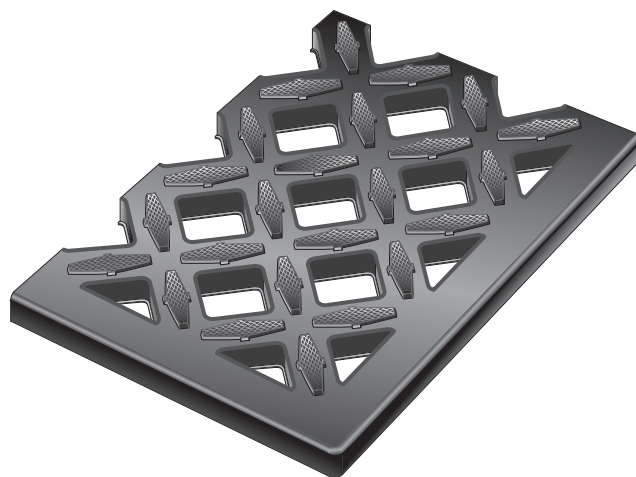

DRAIN-X MAT			
Stock No.	Color	Sizes	App. Wt.
DX-2436B	Black	2' x 3'	7.4 lbs.
DX-2436R	Terra Cotta	2' x 3'	7.4 lbs.
DX-3636B	Black	3' x 3'	11 lbs.
DX-3636R	Terra Cotta	3' x 3'	11 lbs.

Colors: Black, Terra Cotta.
Thickness 1/2" **Pallets** of 25 each.

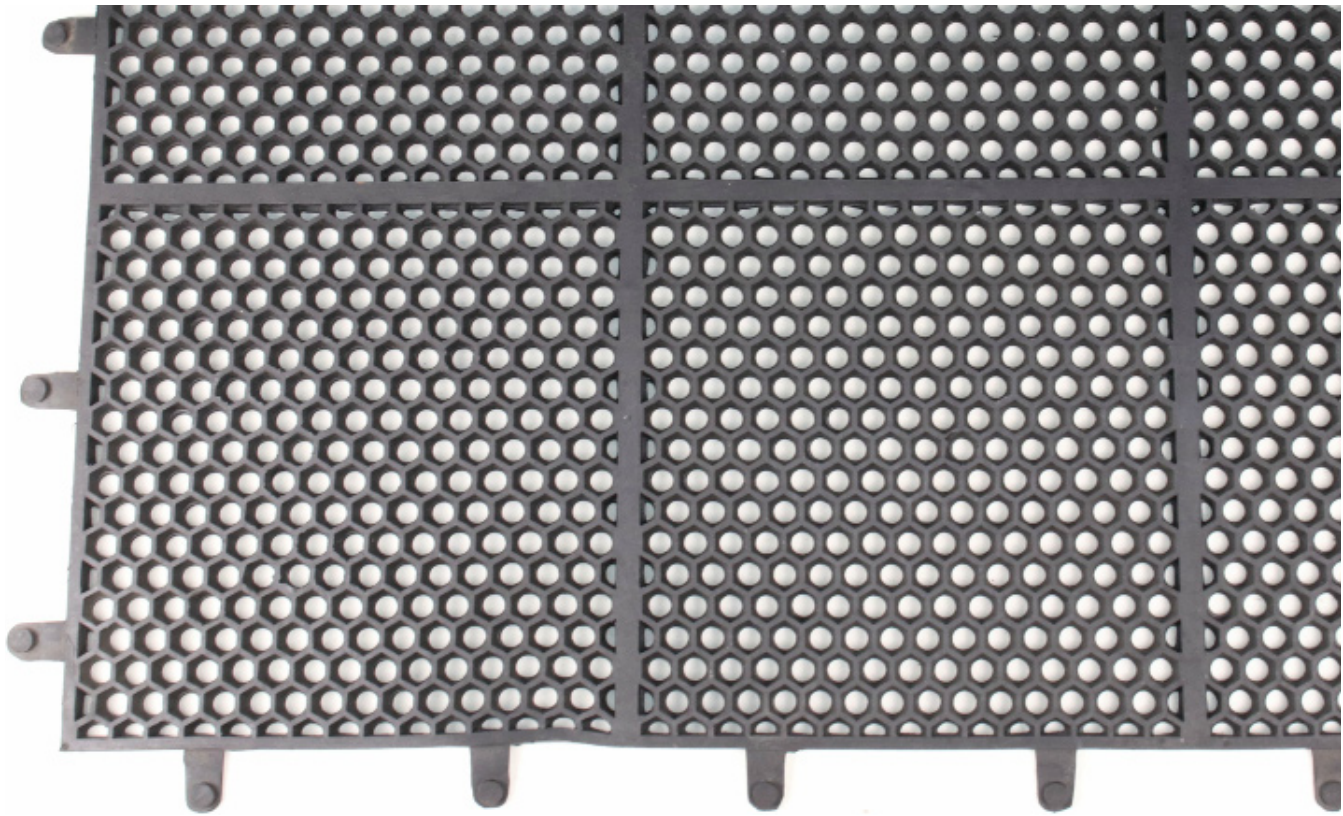

HEX-O-LITE DRAIN-THRU ANTI-FATIGUE

- Hex-O-Lite's honeycomb design is an example of mother nature's geometric efficiency, providing one of the best weight-to-strength ratios known.
- A key ingredient of Hex-O-Lite is tree derived rubber, nature's contribution to the elastomer field offering the advantages of excellent resilience, high tensile strength, tear properties and good flexing qualities at low temperatures.
- Hex-O-lite is lightweight, easy to handle, offered in two sizes and features a built in interlock system for longer lengths and custom configurations.
- Available in grease-resistant Black. Thickness, 1/2"

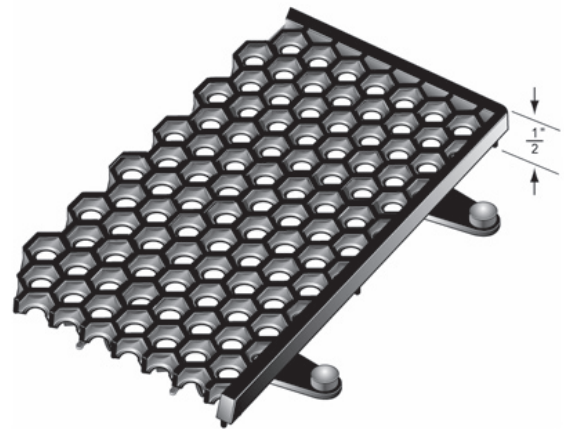

HEX-O-LITE MAT

Stock No.	Color	Sizes	Weight
HC-3636BLK	Black	3' x 3'	9.0 lbs.
HC-3648BLK	Black	3' x 4'	12.0 lbs.

1/2" thick.
Colors: Black.



MULTIMAT™ All Purpose Entry Mats

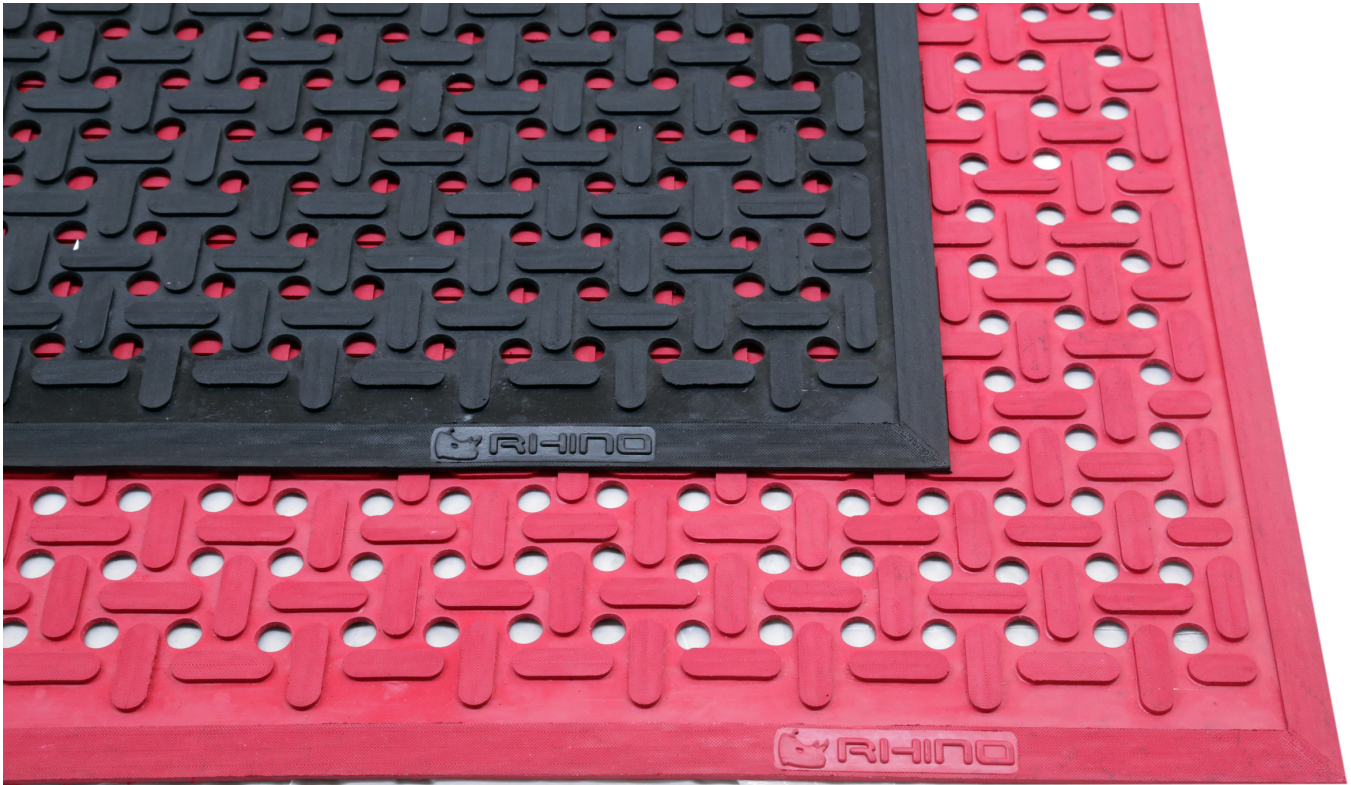

MULTIMAT

- Multimati is easy to handle – at 17 lbs. and 3/8” thick, yet holds securely in-place due to the large textured bar sub-surface pattern.
- Multimati has turned out to be one of the most versatile products we have ever manufactured, used in manufacturing, convenience & grocery store, kitchen and food service applications.
- Available in grease resistant black and grease proof terra cotta.

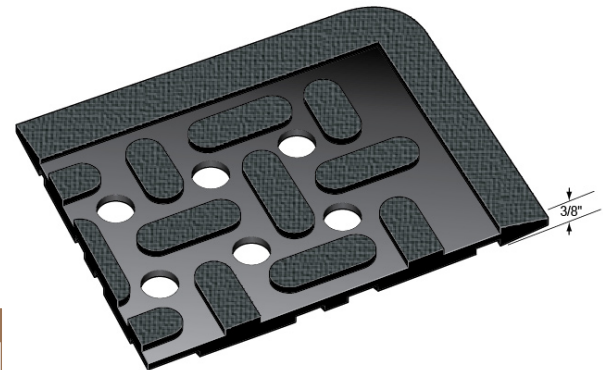

MULTIMAT				
Stock No.	Color	Sizes	Thickness	Weight
UM3660B	Black	36" x 60"	3/8"	28.0 lbs.
UM3660R	Terra Cotta	36" x 60"	3/8"	28.0 lbs.
Color: Black, Terra Cotta. Thickness 3/8"				



PRO-TEX DRAIN-THRU RUNNER

- The Pro-Tex design has been a distributor offering for decades and remains a consumer favorite and the benchmark for comparison to all other runner mat offerings.
- Pro-Tex is a versatile mat that can be used for non-slip service or as an anti-fatigue mat in either manufacturing or food service production environments.
- A raised V-pattern runs side to side on the surface for non-slip with drainage slots and a knob backed underside. Overall thickness is 3/8" for easy on/off cart access.
- Durable grease resistant and grease proof formulations making maximum use of tree-derived rubber harvested from the Para rubber tree. Natural rubber is nature's contribution to the elastomer field and offers the advantages of high resilience, high tensile strength and tear properties, with good flexing qualities at low temperatures.
- Pro-Tex is offered in full rolls or cut lengths and in grease resistant black and grease proof terra cotta.

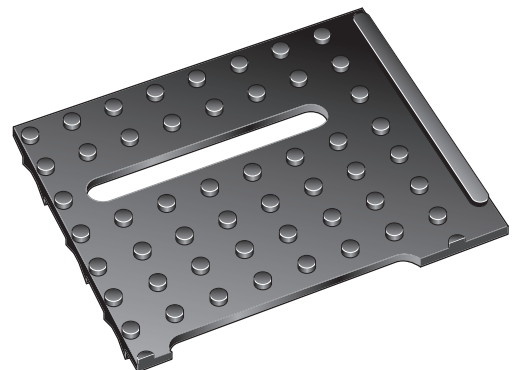
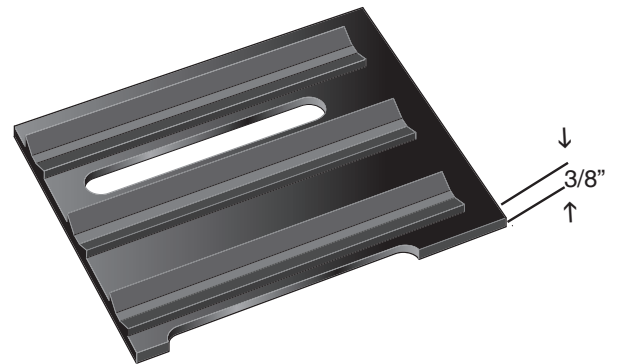

PRO-TEX

Stock No.	Color	Size	Weight Ln. Ft.
PT360BLK	Black	3' x 60'	4.1 lbs.
PT360RED	Terra Cotta	3' x 60'	4.1 lbs.

3/8" thick. Available in full rolls or cut lengths.

Colors: Black, Terra Cotta.



TRAKTOR MAT™ Anti-Slip/Anti-Fatigue



TRAKTOR MAT ANTI-FATIGUE

- Multidirectional non-skid v-rib surface, open slot drain-thru design. Knob-backed to facilitate drainage, air-flow and greater ergonomic comfort.
- This is a great mat for welding, machining, heavy assembly areas, catwalks and grated platforms, forklifts and hand carts.
- Traktor Mat and the Rhino Tritan series from Rhino are manufactured from recycle trim rubber from the tire manufacturing plants of Pirelli® and Michelin®. Both iconic brands renowned for formulating the best rubber compounds in the world. Our utilization of these materials enables us to offer a five year guarantee on the Traktor Mat product.
- Traktor mat is available in 24", 36" and 48" widths in full rolls of 20 feet or cut lengths. Color: Black, 1/2 inch thick.

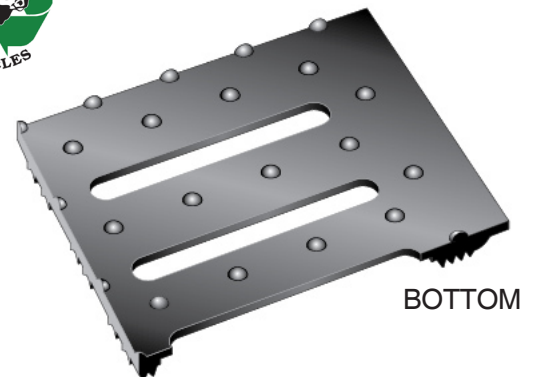

TRAKTOR MAT

Stock No.	Roll Size	Weight per Lin. Ft.
TK-24	2' x 20'	4.0 lbs.
TK-36	3' x 20'	6.1 lbs.
TK-48	4' x 20'	8.2 lbs.

1/2" thick.
Cut lengths or full rolls.
Color: Black.



TRITAN® PERMA WALK

- Tritan Perma-Walk Mats provide safe, secure footing in heavy traffic areas, locker rooms, hockey rinks, golf courses, assembly areas, horse trailers, and warehouse aisles where fork lifts or carts are used.
- One quarter inch wide, flat corrugations running parallel to the length of the mat make sweeping and cleaning a breeze.
- Perma-Walk from Rhino is manufactured from recycle trim rubber from the tire manufacturing plants of Pirelli® and Michelin®. Both iconic brands renowned for formulating the best rubber compounds in the world. Our utilization of these materials enables us to offer a five-year guarantee on the Tritan Perma-Walk product.
- Perma-Walk offers an exceptional value and cost savings when compared to like-gauge (3/8" thick) products.



TRITAN PERMA WALK 3/8" THICK		
Stock No.	Sizes	Wt./Lin. Ft.
TPW36	3/8" x 36" x 75'	4.7 lbs.
TPW48	3/8" x 48" x 75'	6.3 lbs.
Color: Black. 3/8" Thick,		





K-SERIES SAFETY TRACT® Anti-Fatigue Mats

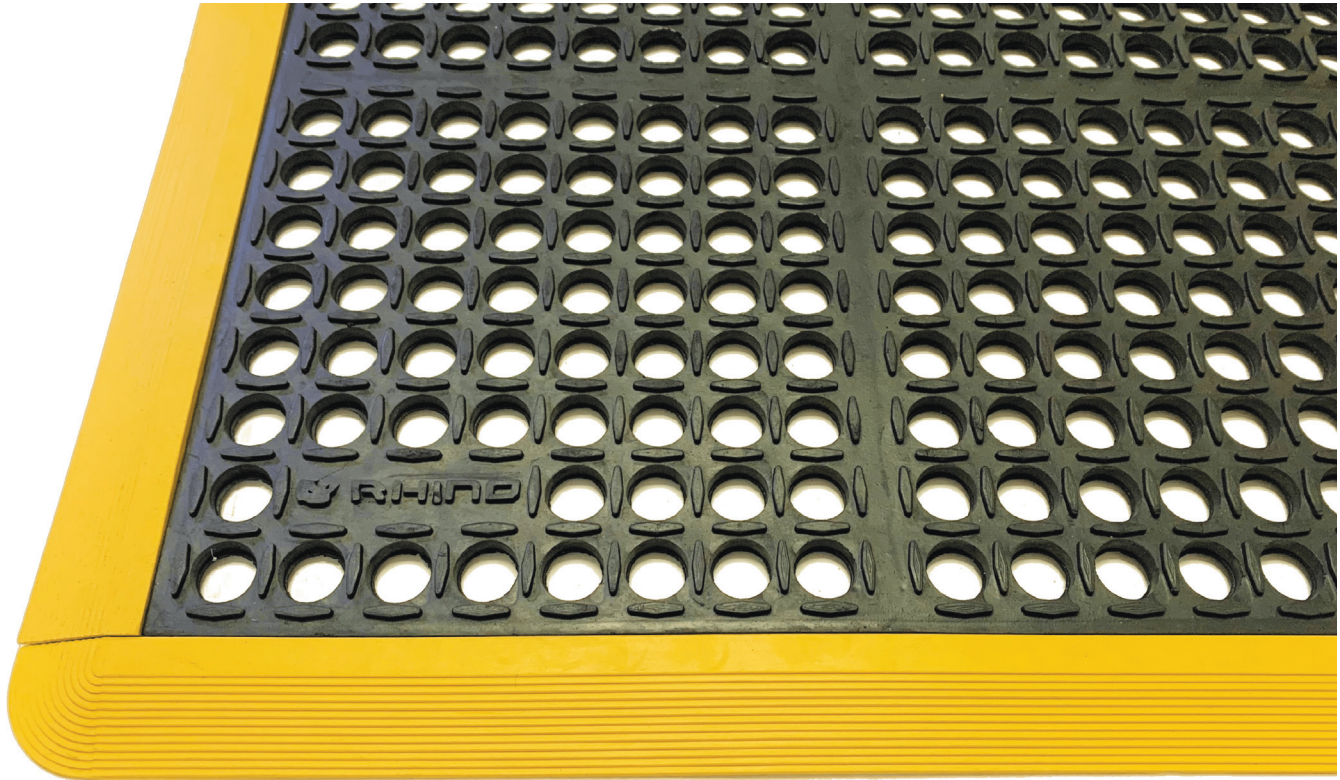

K-SERIES SAFETY TRACT

- Safety Tract provides the safe firm footing and superior anti-fatigue properties required in a rigorous manufacturing environment.
- The K-Series Safety Tract mats and bevels are permanently bonded together, converting it into a mat of one piece construction, bevels are permanently added to three (3) sides, with safety yellow bevels available for extra visibility and good looks.
- Diamond bar surface provides safe sure footing with thick support bars on the underside that enhances comfort while providing stability and superior drainage.
- K-Series Safety Tract mats are manufactured with natural rubber from the Para rubber tree. It has less impact on the environment, it is an ecologically sustainable crop and contributes to the maintenance of global carbon balance in the atmosphere. Nitrile is added to the Safety Tract formulation for added resistance to machine cutting tool fluids, butyl alcohol, sodium hydroxide and similar liquids.
- Safety Tract mats are available in 4 different sizes and configurations ranging from 2'X3's to 3'X10's.

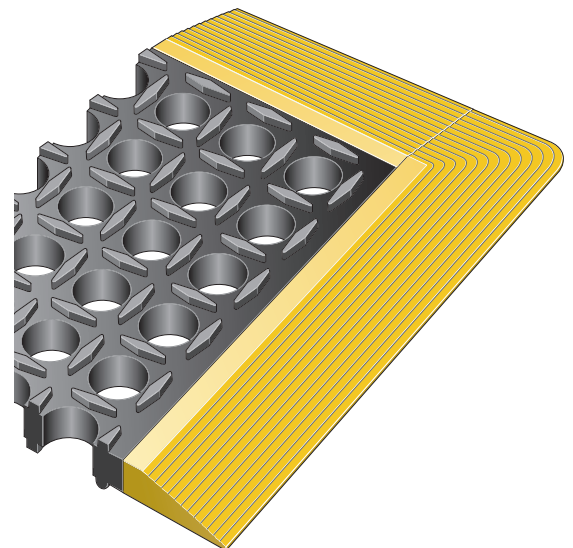

SAFETY TRACT ANTI-FATIGUE		
Stock No.	Sizes	Weight
ST2640Y	26" x 40"	20.0 lbs.
ST3840Y	38" x 40"	22.1 lbs.
ST3864Y	38" x 64"	31.2 lbs.
ST3812Y	38" x 124"	59.8 lbs.
Colors: Black, with Yellow Safety bevels. Custom sizes available.		
Thickness 7/10"		

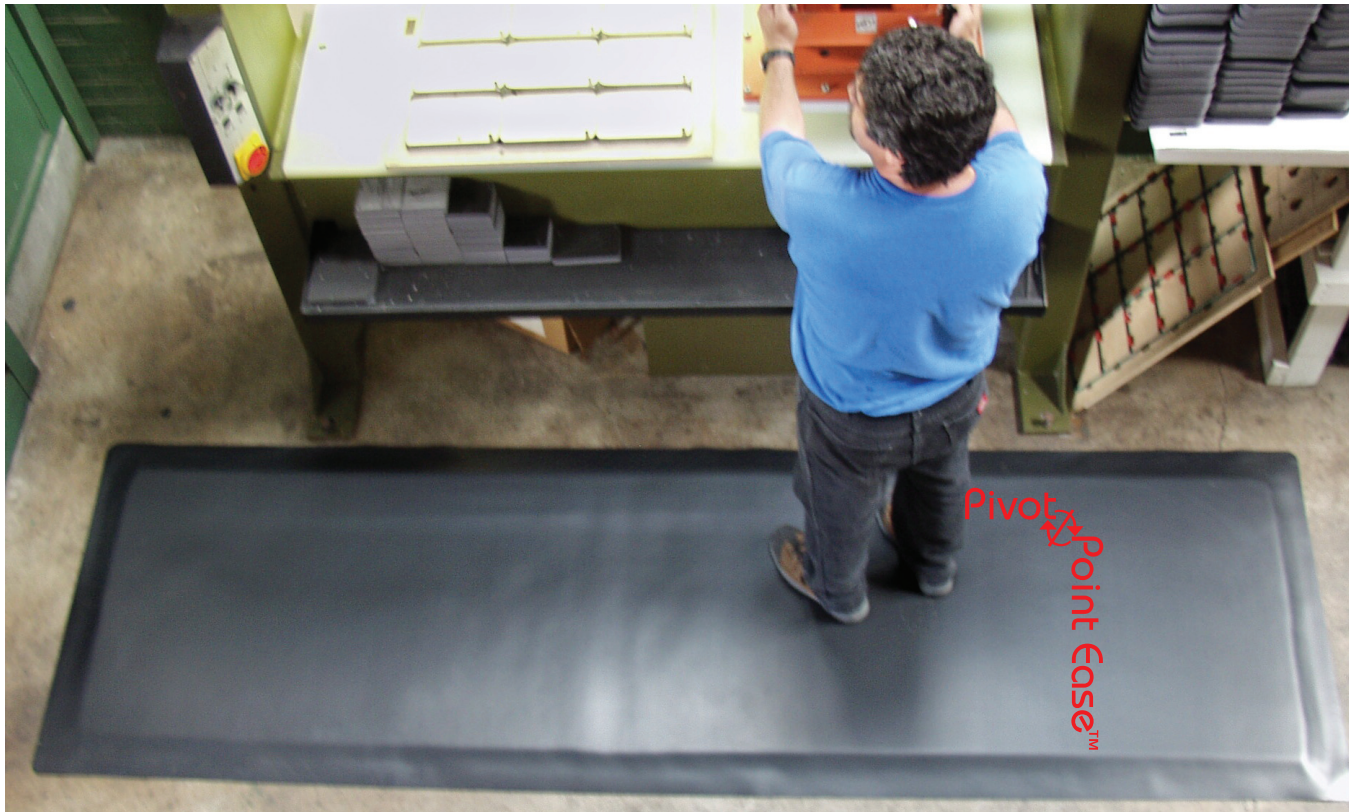

INDUSTRIAL SMOOTH™ ANTI-FATIGUE

- Anti-Fatigue Mat comfort is only one consideration, the next is freedom of movement. Industrial Smooth Anti-Fatigue Mats facilitate the 180-degree to-and-fro movement required at service counters and assembly lines while avoiding the stress on knees and ankles that result when the same movements are made on mats with a molded non-slip surface.
- Industrial Smooth Anti-Fatigue Mats provide that “pivot point ease™” plus the incredibly soft and resilient rebound properties needed in a rigorous commercial environment. The product is a real plus for housekeeping as the smooth top makes cleaning a breeze.
- This product, like our Diamond Plate series, offers excellent durability, suffers no deterioration from weathering, ozone exposure and is self-extinguishing when tested in accordance with FMVSS-302.
- Industrial Smooth Anti-Fatigue Mats are available in two styles. The Heavy duty style is 1/2” thick and the Super Duty is a full 7/8” thick. Both styles are available in individual mats or full roll lengths of 24”, 36”, 48”, 60”, 72”, and 96” widths.
- Edges of sponge base will be beveled to within 2” of the top surface to effectively taper the edges of the surface to the floor and create a visibly molded incline around the perimeter of the mat.
- 3 year warranty.

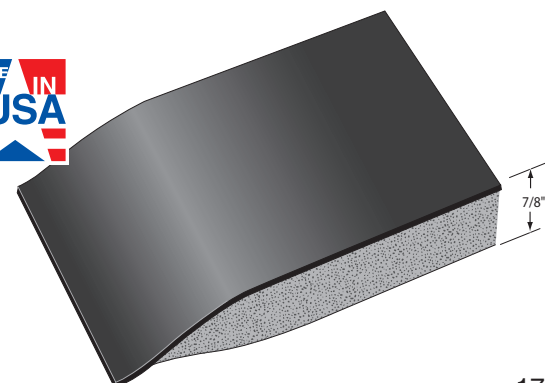
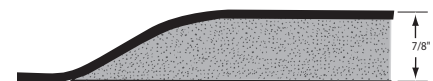
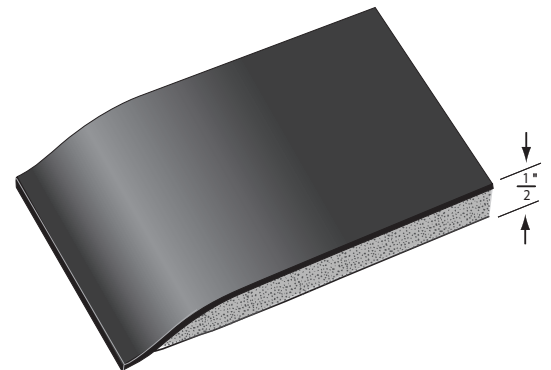

INDUSTRIAL SMOOTH™ ANTI-FATIGUE MATS			
For 7/8” mats, add “DS” to stock number			
Stock No.	Sizes	Weight Ea. 1/2”	Weight Ea. 7/8”
IS2436	2’ x 3’	9.0 lbs.	10.0 lbs.
IS3660	3’ x 5’	19.0 lbs.	22.0 lbs.
Custom Sizes - available in lengths up to 75 lin. ft.			
Stock No.	Width	Weight/Lin.Ft. 1/2”	Weight/Lin Ft. 7/8”
IS24	24”	2.2 lbs.	2.6 lbs.
IS36	36”	3.3 lbs.	3.9 lbs.
IS48	48”	4.4 lbs.	5.2 lbs.
IS60	60”	5.5 lbs.	6.5 lbs.
IS72	72” Seamed	6.6 lbs.	7.8 lbs.
IS96	96” Seamed	8.8 lbs.	10.4 lbs.
Color: Black. 7/8” Thick/Double Sponge (DS)			



REFLEX™ THE INTERACTIVE ANTI-FATIGUE MAT

- Interactive mat is a term describing the Reflex anti-fatigue mat whose input and output are interconnected producing a combination of resilience and stimulation working together for an effect that rejuvenates as energy is expended.
- Reflex Anti-Fatigue Mats provide this *dual* action blend with buoyant polymer sponge and vertical column support domes.
 - The super resilient closed-cell polymeric sponge base encourages a subtle and constant series of small adjustments to leg and calf muscles. Adjusting to the flexibility of the mat increases blood flow by the interaction between muscles and veins, resulting in improved circulation and reduced fatigue.
 - The solid domed Reflex surface is compliant, to the shape of the foot, providing equal support of the entire footprint; simultaneously aggressive, providing upward vertical force and simple manipulation of the feet. This relieves tension, stimulates circulation and breaks up patterns of stress in all areas of the body to an amazing extent.
- Relating to the external conditions of the workplace, productivity gains through the use of anti-fatigue mats are second only to heating and air conditioning. The bonus is safety and well-being.
- 5 year warranty.
- Reflex Anti-Fatigue Mats are available in two thicknesses:



Heavy Duty - 5/8" thick mats

Recommended in areas where tasks require personnel to move around in large work stations.

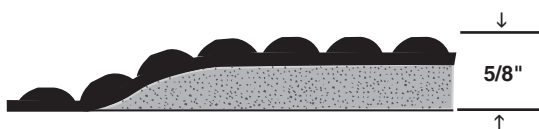

Super Duty - 1" thick mats

The anti-fatigue mat of choice in standing work stations delivering unparalleled comfort.

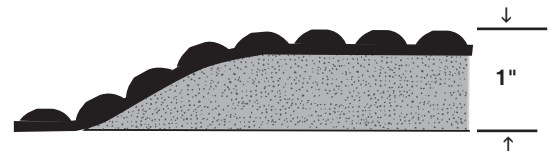

BLACK/YELLOW

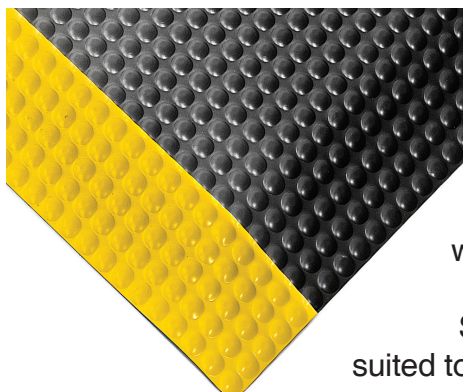

INDUSTRIAL BLACK

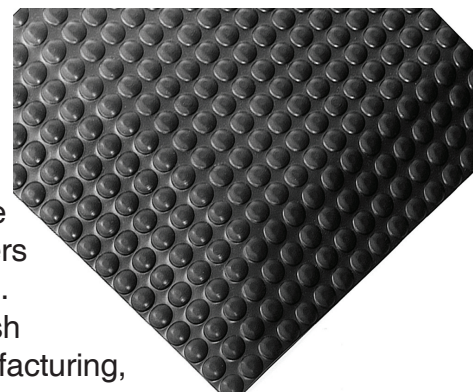

INDUSTRIAL
 High-Tech
 non-directional surface
 with safety yellow borders
 to highlight work areas.
 Solid Black is a flat finish
 suited to assembly lines, manufacturing,
 shipping and packing work stations.

*** Patent D543765**

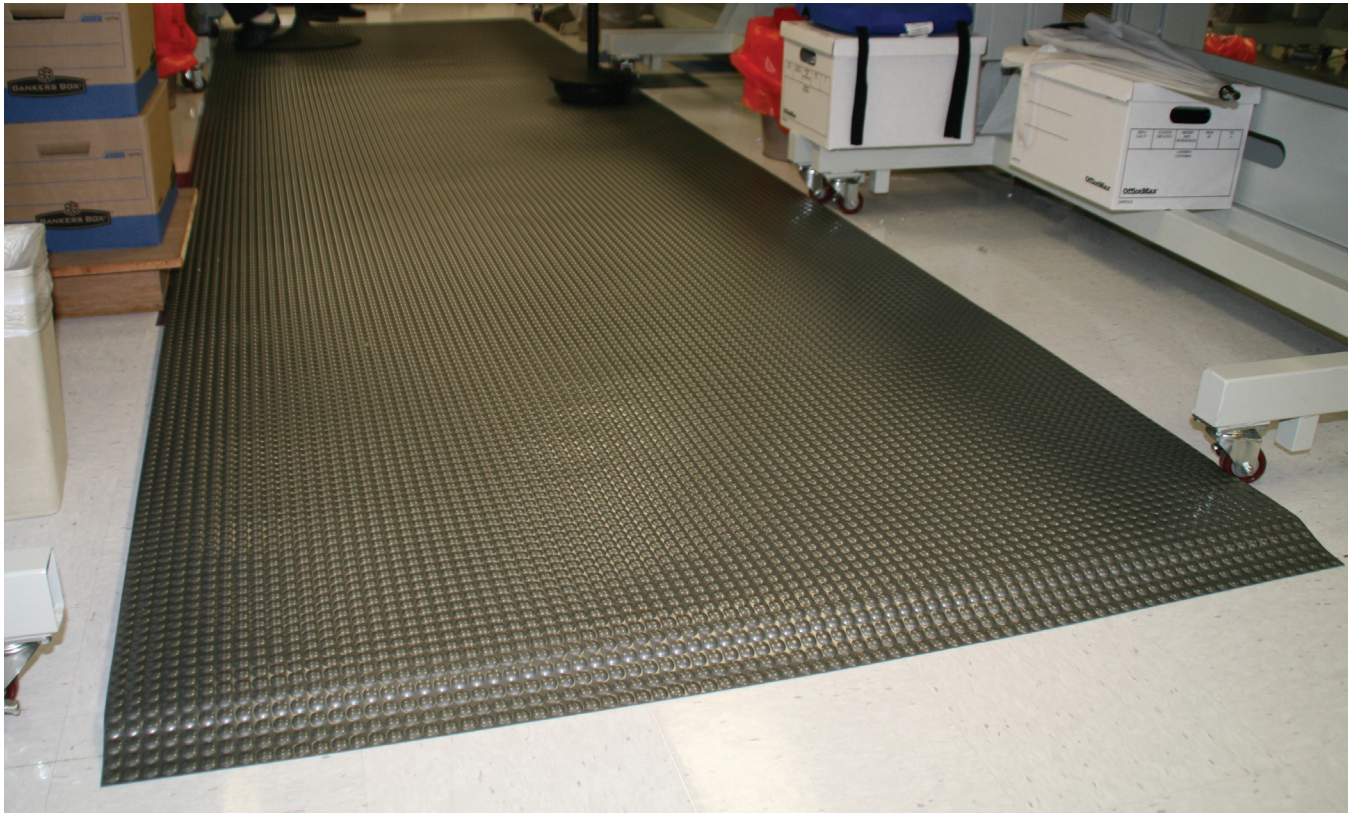

REFLEX ANTI-FATIGUE

For 1" mats, Add "DS" to stock number

Stock No.	Sizes	Weight Ea. 5/8"	Weight Ea. 1"
RFLX2436	2' x 3'	9.0 lbs.	10.2 lbs.
RFLX3660	3' x 5'	22.0 lbs.	28.0 lbs.

Custom Sizes - available in lengths up to 75 lin. ft.

Stock No.	Width	Weight/Lin.Ft. 5/8"	Weight/Lin. Ft. 1"
RFLX24	24"	3.0 lbs.	3.8 lbs.
RFLX36	36"	4.5 lbs.	5.7 lbs.
RFLX48	48"	6.0 lbs.	7.6 lbs.
RFLX60	60"	7.5 lbs.	9.5 lbs.
RFLX72	72" Seamed	9.0 lbs.	11.4 lbs.
RFLX96	96" Seamed	12.0 lbs.	15.2 lbs.

Commercial Colors: Black Glossy and Metallic. **Industrial Colors:** Industrial Black, Black/Yellow.

METALLIC

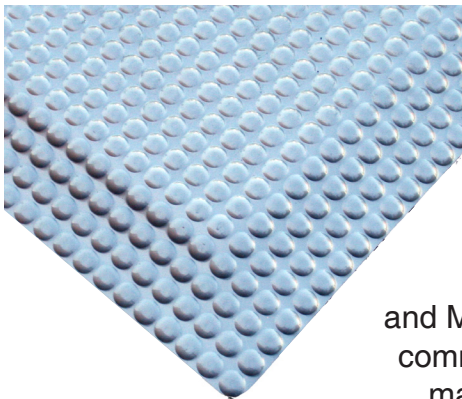

BLACK GLOSSY

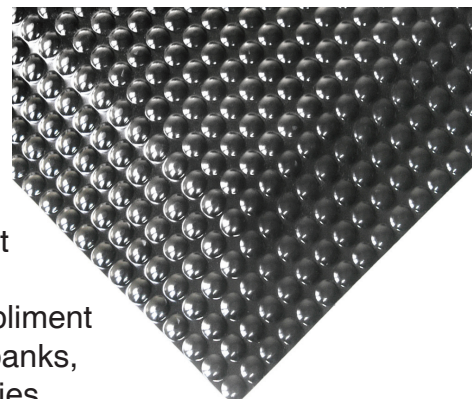

COMMERCIAL

Same physical properties as our industrial series except with the Glossy Black and Metallic surface to compliment commercial offices, retail, banks, mail rooms and laboratories.



AMERICAN CLASSIC DIAMOND™ Anti-Fatigue Mats

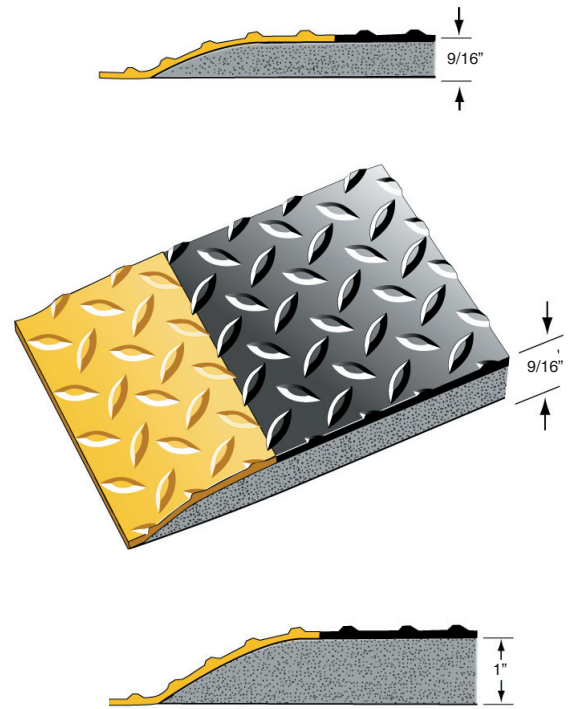

AMERICAN CLASSIC DIAMOND ANTI-FATIGUE

- American Standard Diamond Anti-Fatigue by Rhino is the benchmark for comparison to all other Industrial Anti-Fatigue Mats. This American Standard suffers no deterioration from weathering and ozone exposure and is self-extinguishing when tested in accordance with FMVSS-302. These mats offer excellent durability following exposure to many organic and inorganic industrial chemicals.
- Shop and compare, Rhino's American Standard Diamond Anti-Fatigue far exceeds the competition with its closed cell polymeric sponge base that produces the incredibly soft and resilient rebound properties needed in a rigorous manufacturing environment.
- This industrial standard is available in two styles. The Heavy duty style is 9/16" thick and the Super Duty is a full 1" thick. Both styles are available in individual mats or full roll lengths of 24", 36", 48", 60", 72", and 96" widths.
- 3 year warranty.

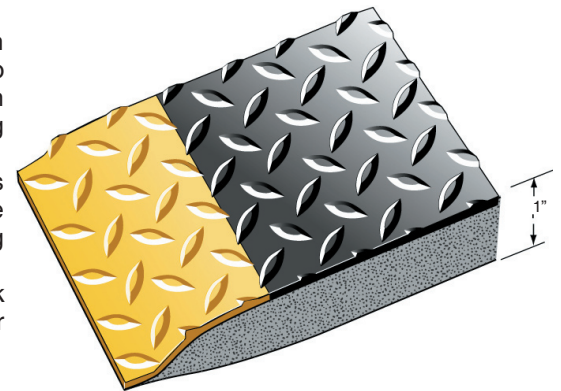

AMERICAN CLASSIC DIAMOND ANTI-FATIGUE MATS

Stock No.	Sizes	Weight Ea. 9/16"	Weight Ea. 1"
DTT2436	2' x 3'	9.0 lbs.	10.0 lbs.
DTT3660	3' x 5'	19.0 lbs.	22.0 lbs.
Custom Sizes - available in lengths up to 75 lin. ft.			
Stock No.	Width	Weight/Lin.Ft. 9/16"	Weight/Lin Ft. 1"
DTT24	24"	1.8 lbs.	2.2 lbs.
DTT36	36"	2.8 lbs.	3.44 lbs.
DTT48	48"	3.8 lbs.	4.6 lbs.
DTT60	60"	4.75 lbs.	5.0 lbs.
DTT72	72" Seamed	5.6 lbs.	6.88 lbs.
DTT96	96" Seamed	7.6 lbs.	9.2 lbs.
Full Rolls	Sizes	Weight Ea. 9/16"	Weight Ea. 1"
DTT275	2' x 75'	135.0 lbs.	165.0 lbs.
DTT375	3' x 75'	210.0 lbs.	258.0 lbs.
DTT475	4' x 75'	285.0 lbs.	345.0 lbs.
DTT575	5' x 75'	357.0 lbs.	516.0 lbs.
DTT675	6' x 75' Seamed	570.0 lbs.	690.0 lbs.

Color: Black, Solid Gray, Gray/Yellow, Black/Yellow. 60" Black & Black/Yellow only. 1" Thick/Double Sponge (DS)

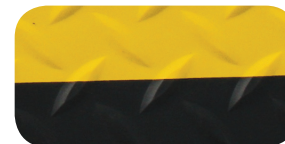

Black/Yellow



Gray/Yellow

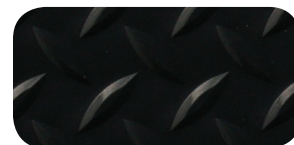

Black



Gray

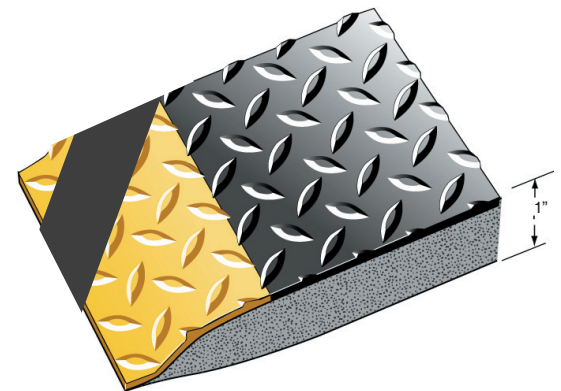
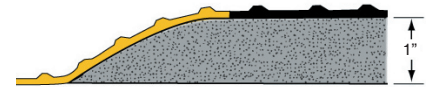
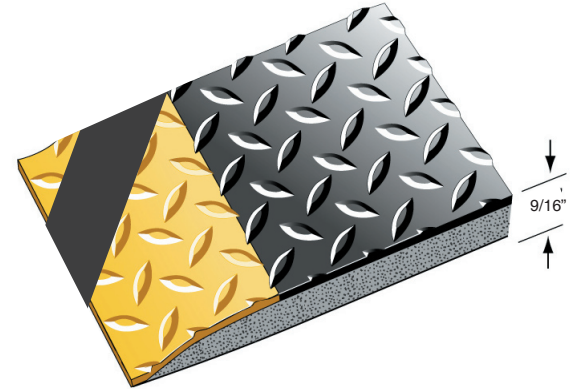
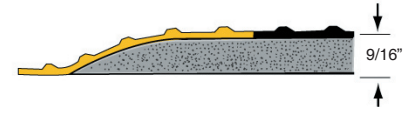

DIAMOND PLATE ANTI-FATIGUE with CHEVRON

- Diamond Plate Anti-Fatigue by Rhino is the benchmark for comparison to all other Industrial Anti-Fatigue Mats. This strong performer suffers no deterioration from weathering and ozone exposure and is self-extinguishing when tested in accordance with FMVSS-302. These mats offer excellent durability following exposure to many organic and inorganic industrial chemicals.
- Shop and compare, Rhino's Diamond Plate Anti-Fatigue far exceeds the competition with it's closed cell polymeric sponge base that produces the incredibly soft and resilient rebound properties needed in a rigorous manufacturing environment.
- This industrial variation is available in two styles. The Heavy duty style is 9/16" thick and the Super Duty is a full 1" thick.
- Edges of sponge base will be beveled to within 2" of the top surface to effectively taper the edges of the surface to the floor and create a visibly molded incline around the perimeter of the mat. Both styles are available in individual mats or full roll lengths of 24", 36", and 48", widths.
- 3 year warranty.

DIAMOND PLATE ANTI-FATIGUE MATS with CHEVRON

Stock No.	Sizes	Weight Ea. 9/16"	Weight Ea. 1"
DTT2436CV	2' x 3'	9.0 lbs.	10.0 lbs.
DTT3660CV	3' x 5'	19.0 lbs.	22.0 lbs.
Custom Sizes - available in lengths up to 75 lin. ft.			
Stock No.	Width	Weight/Lin.Ft. 9/16"	Weight/Lin Ft. 1"
DTT24CV	24"	2.2 lbs.	2.6 lbs.
DTT36CV	36"	3.3 lbs.	3.9 lbs.
DTT48CV	48"	4.4 lbs.	5.2 lbs.

Color: Black/Yellow Chevron. 24", 36", and 48" only.

Add "DS" for double sponge. Add "4" for 4-side Chevron.

RHI-NO-SLIP add RNS (9/16")





DIAMOND PLATE BRITE™ Anti-Fatigue Mats

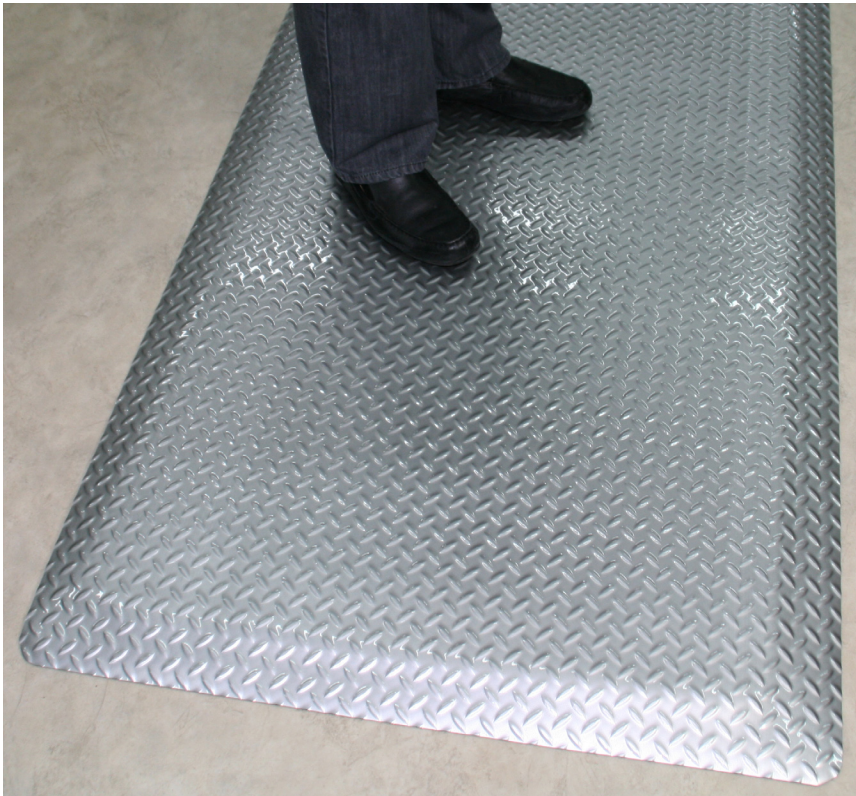

DIAMOND PLATE BRITE ANTI-FATIGUE

- The reflective properties in Diamond Plate Brite Anti-Fatigue mats support lighting quality, help eliminate the need for task lighting and create uniform shadow free illumination in production & personnel areas where you need it most.
- Improvements in workplace illumination can create an increase in general well being, help alleviate the common subclinical problems among night shift workers.
- Diamond Plate Brite is made from the same exceptionally durable compound as our Standard Diamond plate series but feature a semi-reflective top surface that offers full-spectrum reflectivity combined with the incredibly soft and resilient rebound properties demanded of a anti-fatigue mat in rigorous commercial and industrial use.
- This product, like our Diamond Plate series, offers excellent durability, suffers no deterioration from weathering, ozone exposure and is self-extinguishing when tested in accordance with FMVSS-302.
- Diamond Plate Brite Anti-Fatigue mats are available in two styles. The Heavy-Duty style is 9/16" thick and the Super duty is a full 1" thick. Both styles are available in individual mats or full roll lengths of 36" and 72" widths.
- Edges of sponge base will be beveled to within 2" of the top surface to effectively taper the edges of the surface to the floor and create a visibly molded incline around the perimeter of the mat. 3 year warranty.



DIAMOND PLATE BRITE ANTI-FATIGUE MATS			
Stock No.	Sizes	Weight Ea. 9/16"	Weight Ea. 1"
DTB2436	2' x 3'	9.0 lbs.	10.0 lbs.
DTB3660	3' x 5'	19.0 lbs.	22.0 lbs.
Custom Sizes - available in lengths up to 75 lin. ft.			
Stock No.	Width	Weight/Lin.Ft. 9/16"	Weight/Lin Ft. 1"
DTB36	36"	3.3 lbs.	3.9 lbs.
DTB72	72" Seamed	6.6 lbs.	7.8 lbs.
Full Rolls	Sizes	Weight Ea. 9/16"	Weight Ea. 1"
DTB375	3' x 75'	248.0 lbs.	340.0 lbs.
DTB675	6' x 75' Seamed	500.0 lbs.	600.0 lbs.
Color: Shiny Metallic, Glossy Black. 1" Thick/Double Sponge (DS)			



Glossy Platinum

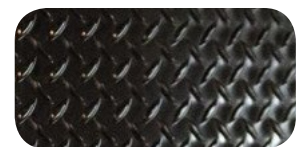

Glossy Black

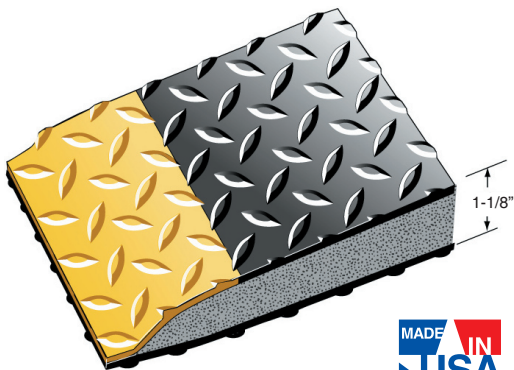
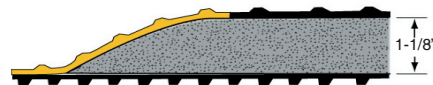
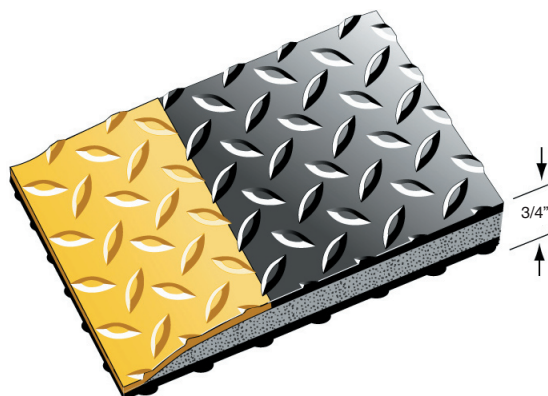
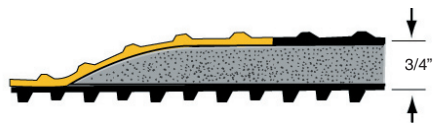

DIAMOND PLATE / KNOB BACK

- The comfort and durability of Diamond Plate Anti-Fatigue matting in a configuration that makes it suitable for wet area applications, areas that were previously restricted to the traditional molded products with marginal anti-fatigue performance.
- This new Diamond Plate/Knob Back Anti-Fatigue matting is self-extinguishing and chemical resistant.
- Diamond Plate/Knob Back has a 5/32" thick diamond plate surface permanently bonded to your choice of a 3/8 " or 3/4" thick resilient closed cell polymeric sponge base.
- The knob back base is permanently bonded to the diamond plate surface creating a sealed envelope that totally encapsulates the sponge core.
- The Diamond Plate/Knob Back matting is available in two styles. The heavy-duty style is 3/4" thick and the super-duty is 1 1/8" thick.
- All edges are beveled and sealed for safety and durability.
- There are four different surface colors to choose from.
- 2 year warranty.

DIAMOND PLATE/KNOB BACK ANTI-FATIGUE MATS			
For 1 1/8" mats, add "DS" to stock number			
Stock No.	Sizes	Weight Ea. 3/4"	Weight Ea. 1 1/8"
DTK2436	2' x 3'	10.5 lbs.	14.7 lbs.
DTK3660	3' x 5'	30.0 lbs.	39.0 lbs.
CUSTOM SIZES-available in lengths up to 60 lin. Ft.			
Stock No.	Widths	Wt./Lin. Ft. 3/4"	Wt./Lin Ft. 1 1/8"
DTK36	36"	6.5 lbs.	7.9 lbs.
Colors: Black, Black/Yellow, Gray/Yellow, Solid Gray. 1 1/8" Thick/Double Sponge (DS)			



Black/Yellow



Gray/Yellow

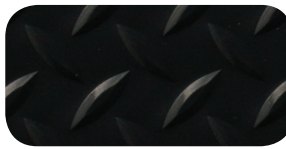

Black

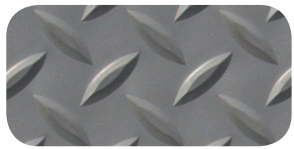

Gray



DIAMOND PLATE RHI-NO-SLIP Anti-Fatigue Sponge Back



DIAMOND PLATE ANTI-FATIGUE with RHI-NO-SLIP

- Diamond Plate Anti-Fatigue mats with the Rhi-No-Slip sponge back utilize the same surface as our regular Diamond Plate mats, with the difference being the use of our special non-slip, vinyl nitrate sponge base.
- Rhi-No-Slip Sponge is resilient with a slightly slower rebound, distributes energy more broadly, increases friction and reduces mat slippage on ceramic tile, painted or epoxy sealed concrete or vinyl sheet flooring.
- This characteristic makes this product exceptionally well suited for smaller size mats in open areas.
- Unlike competitive products, Rhi-No-Slip is “not” a tacky-back product and does “not” accumulate and hold floor contamination.
- Beveled sponge substrate guarantees lay-flat, and unlike competitive products, the sponge extends to within 1.5 inches of top surface for 20% more coverage and usable area. This is a “Best-in-Class mat”, you will not be disappointed.
- Available in a 9/16” or 1” thickness. Solid Black & Black with Yellow border. Both styles are available in individual mats or in cut lengths from 24”, 36” & 48” widths. 3 year warranty.

DIAMOND PLATE ANTI-FATIGUE with RHI-NO-SLIP

Stock No.	Sizes	Weight Ea. 9/16”	Weight Ea. 1”
DTT2436	2' x 3'	9.0 lbs.	10.0 lbs.
DTT3660	3' x 5'	19.0 lbs.	22.0 lbs.
Custom Sizes - available in lengths up to 75 lin. ft.			
Stock No.	Width	Weight/Lin.Ft. 9/16”	Weight/Lin Ft. 1”
DTT24	24”	1.8 lbs.	2.2 lbs.
DTT36	36”	2.8 lbs.	3.44 lbs.
DTT48	48”	3.8 lbs.	4.6 lbs.
Full Rolls	Sizes	Weight Ea. 9/16”	Weight Ea. 1”
DTT275	2' x 75'	135.0 lbs.	165.0 lbs.
DTT375	3' x 75'	210.0 lbs.	258.0 lbs.
DTT475	4' x 75'	285.0 lbs.	345.0 lbs.

Color: Black, Black/Yellow.
1” Thick/Double Sponge (DS)

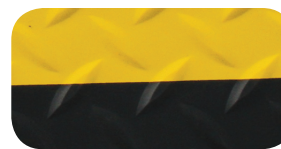

Black/Yellow

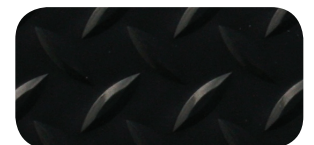

Black

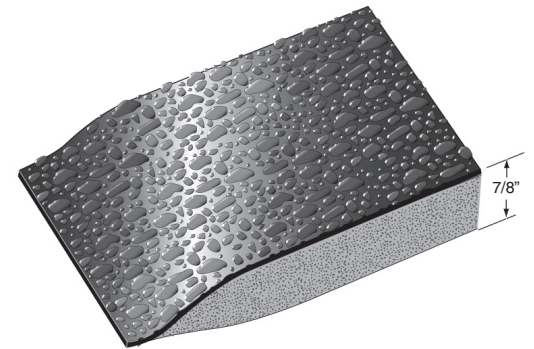
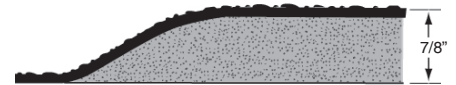
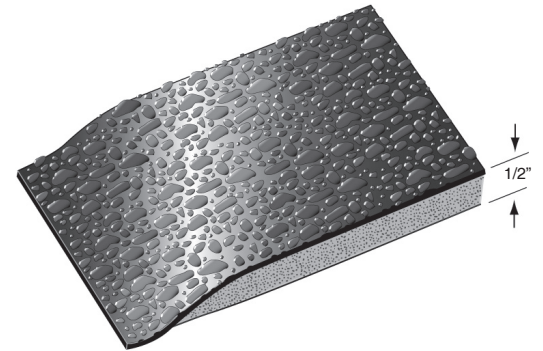
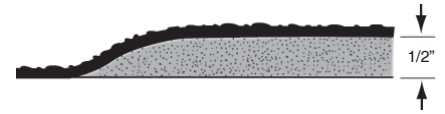

RHINO HIDE®

- Beautiful high-gloss pebble surface of non-porous Koroseal vinyl. Full 1/8" thick top surface provides resistance to punctures from heels, cart traffic, tears, cuts, and is over three times more abrasion resistant than competing products.
- A super resilient closed cell polymeric sponge base provides exceptional buoyancy to reduce fatigue plus a surface for the toughest environments. Permanently bonded to a 3/8" or 3/4" resilient sponge base, overall thickness is 1/2" or 7/8".
- Edges of sponge base will be beveled to within 2" of top surface to effectively taper the edges of the surface to the floor and create a visibly molded incline around the perimeter of the mat.
- Two year conditional, non-prorated warranty insures against cracking or fracturing.



Serengeti Sunrise

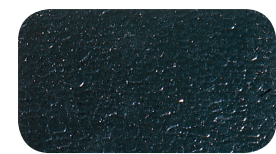

Nigerian Night



Nile Mist

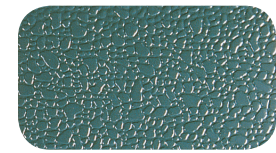

Congo Green



Sahara Sand

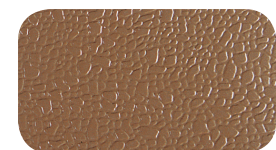

Kenya Trail

RHINO HIDE® ANTI-FATIGUE MATS			
For 7/8" mats, add "DS" to stock number			
Stock No.	Sizes	Weight Ea. 1/2"	Weight Ea. 7/8"
RH-2436	2' x 3'	10.0 lbs.	12.0 lbs.
RH-3660	3' x 5'	25.0 lbs.	30.0 lbs.
CUSTOM SIZES-available in lengths up to 75 lin. Ft.			
Stock No.	Widths	Wt./Lin. Ft. 1/2"	Wt./Lin Ft. 7/8"
RH-24	24"	3.25 lbs.	4.0 lbs.
RH-36	36"	5.00 lbs.	6.0 lbs.
RH-48	48"	6.50 lbs.	8.0 lbs.
RH-72	72" SEAMED	10.00 lbs.	12.0 lbs.
RH-96	96" SEAMED	13.00 lbs.	16.0 lbs.
Colors: Congo Green, Sahara Sand (Tan), Serengeti Sunrise (Red), Kenya Trail (Brown), Nigerian Night (Black), Nile Mist (Gray).			
7/8" Thick/Double Sponge (DS)			



MARBLEIZED TILE TOP™ Anti-Fatigue Mats

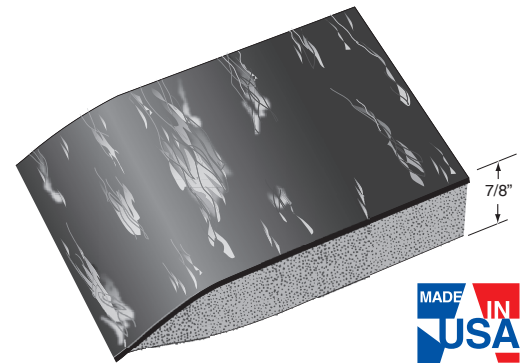
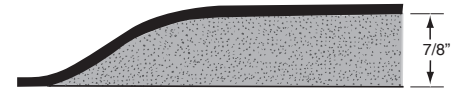
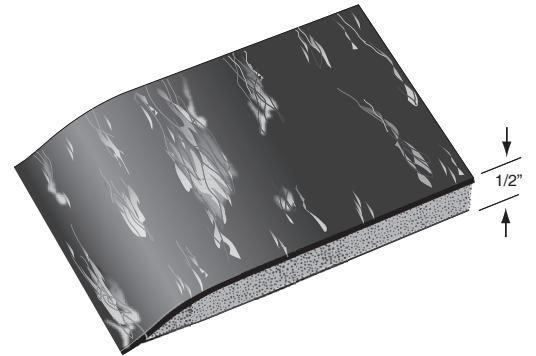
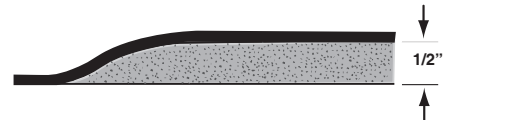

MARBLEIZED TILE TOP ANTI-FATIGUE

- An anti-fatigue mat that provides comfort for people who stand behind counters in pharmacies and teller stations, widely used in laboratories and check-stand applications.
- The marbled top surface is a heavy duty 3/32" low static vinyl formulation. Surface shall be permanently fused to either a 3/8" or 3/4" thick a closed cell polymeric sponge base comprised of polyvinyl chloride, acrylonitrile butadiene rubber and chloroprene. Sponge base will have a skin surface to block moisture to resist oils and industrial chemicals.
- Edges of sponge base will be beveled to within 2" of the top surface to effectively taper the edges of the surface to the floor and create a visibly molded incline around the perimeter of the mat.
- Overall thickness is 1/2" or 7/8", available in standard stock sizes and in full rolls or custom lengths.



Blue



Solid Black



Brown

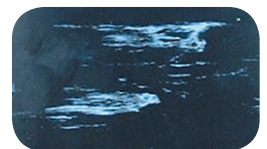

Black/White

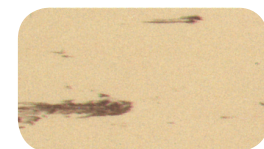

Tan



Gray



Charcoal

MARBLEIZED TILE TOP ANTI-FATIGUE MATS

For 7/8" mats, add "DS" to stock number

Stock No.	Sizes	Weight Ea. 1/2"	Weight Ea. 7/8"
TT-1830	18" x 30"	4.5 lbs.	5.5 lbs.
TT-1848	18" x 48"	7.5 lbs.	8.5 lbs.
TT-2436	24" x 36"	7.5 lbs.	8.5 lbs.
TT-3660	36" x 60"	17.0 lbs.	21.0 lbs.

CUSTOM SIZES – available in lengths up to 60 lin. Ft.

Stock No.	Widths	Wt./Lin. Ft. 1/2"	Wt./Lin Ft. 7/8"
TT-R24	24"	2.4 lbs.	2.8 lbs.
TT-R36	36"	3.6 lbs.	4.2 lbs.
TT-R48	48"	4.8 lbs.	5.6 lbs.
TT-R60	60"	6.0 lbs.	7.0 lbs.
TT-R72	72" Seamed	7.2 lbs.	8.4 lbs.
TT-R96	96" Seamed	9.6 lbs.	11.2 lbs.

Colors: Brown, Gray, Tan, Charcoal, Blue, Black/White. (60" in Solid Black only.) 7/8 " Thick/Double Sponge (DS)

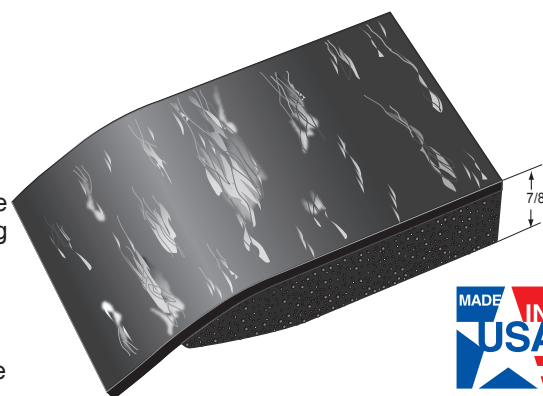

MARBLEIZED TILE TOP with RHI-NO-SLIP

- Marbleized Tile Top Anti-Fatigue mats with the Rhi-No-Slip sponge back utilize the same surface as our regular Diamond Plate mats, with the difference being the use of our special non-slip, vinyl nitrate sponge base.
- Rhi-No-Slip Sponge is resilient with a slightly slower rebound, distributes energy more broadly, increases friction and reduces mat slippage on ceramic tile, painted or epoxy sealed concrete or vinyl sheet flooring.
- This characteristic makes this product exceptionally well suited for smaller size mats in open areas.
- Unlike competitive products, Rhi-No-Slip is “not” a tacky-back product and does “not” accumulate and hold floor contamination.
- Beveled sponge substrate guarantees lay-flat, and unlike competitive products, the sponge extends to within 1.5 inches of top surface for 20% more coverage and usable area. This is a “Best-in-Class mat”, you will not be disappointed.
- Available in a 1/2” or 7/8” thickness. Solid Black & Black with Yellow border. Both styles are available in individual mats or in cut lengths from 24”, 36” & 48” widths. 3 year warranty.

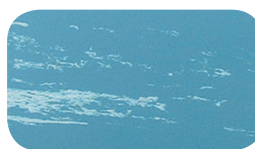

Blue



Solid Black



Brown

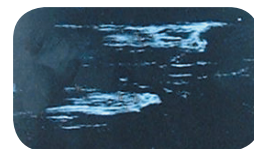

Black/White

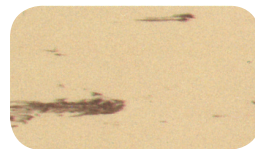

Tan

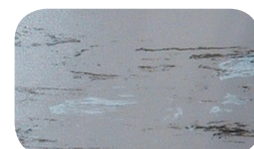

Gray

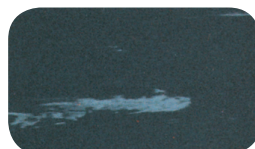

Charcoal

MARBLEIZED TILE TOP with RHI-NO-SLIP

For 7/8” mats, add “DS” to stock number

Stock No.	Sizes	Weight Ea. 1/2”	Weight Ea. 7/8”
TT-1830	18” x 30”	4.5 lbs.	5.5 lbs.
TT-1848	18” x 48”	7.5 lbs.	8.5 lbs.
TT-2436	24” x 36”	7.5 lbs.	8.5 lbs.
TT-3660	36” x 60”	17.0 lbs.	21.0 lbs.

CUSTOM SIZES – available in lengths up to 60 lin. Ft.

Stock No.	Widths	Wt./Lin. Ft. 1/2”	Wt./Lin Ft. 7/8”
TT-R24	24”	2.4 lbs.	2.8 lbs.
TT-R36	36”	3.6 lbs.	4.2 lbs.
TT-R48	48”	4.8 lbs.	5.6 lbs.

Colors: Brown, Gray, Tan, Charcoal, Blue, Black/White. 7/8 “ Thick/ Double Sponge (DS)



WILD CHERRY

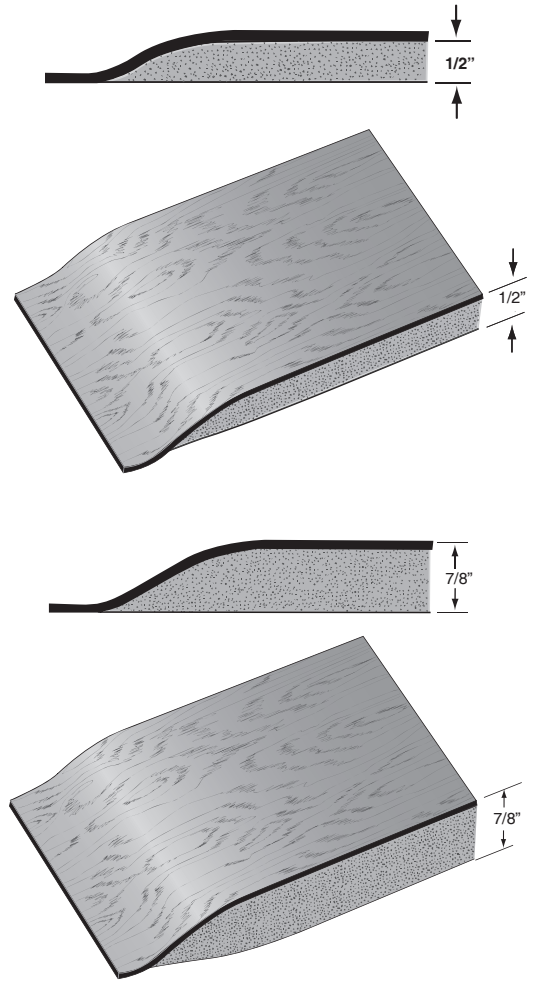

SOFT WOODS

- The beautiful Soft Woods anti-fatigue mat establishes a new standard of beauty in anti-fatigue mats.
- The rich look of hardwood flooring enhances your work place while providing the simplest and most effective way to reduce fatigue and stress.
- Soft Woods anti-fatigue mats are available in two styles. The single sponge style is 1/2" thick and the double sponge is a full 7/8" thick, double the thickness of ordinary mats.
- Double sponge mats by Rhino are the anti-fatigue mats of choice, producing the incredibly soft and resilient rebound properties needed in a rigorous commercial or retail environment.
- Edges of sponge base will be beveled to within 2" of top surface to effectively taper the edges of the surface to the floor and create a visibly molded incline around the perimeter of the mat.

WALNUT

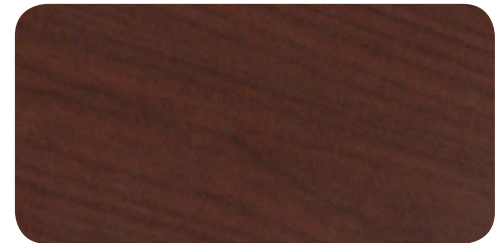

WILD CHERRY

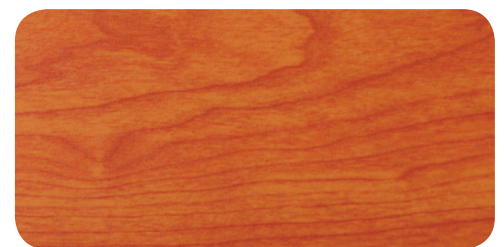

SOFT WOODS ANTI-FATIGUE MATS

For 7/8" mats, add "DS" to stock number

Stock No.	Size	Weight Ea. 1/2"	Weight 7/8"
SW-2436	2' x 3'	7.5 lbs.	8.5 lbs. ea.
SW-3660	3' x 5'	17.0 lbs.	21.0 lbs. ea.

CUSTOM SIZES-available in lengths up to 60 lin. Ft.

Stock No.	Widths	Wt./Lin. Ft. 1/2"	Wt./Lin. Ft. 7/8"
SW-24	24"	2.4 lbs./Ln. Ft.	2.8 lbs./Ln. Ft.
SW-36	36"	3.6 lbs./Ln. Ft.	4.2 lbs./Ln. Ft.
SW-48	48"	4.8 lbs./Ln. Ft.	5.6 lbs./Ln. Ft.

Colors: Wild Cherry, Walnut.

7/8" Thick/Double Sponge (DS)



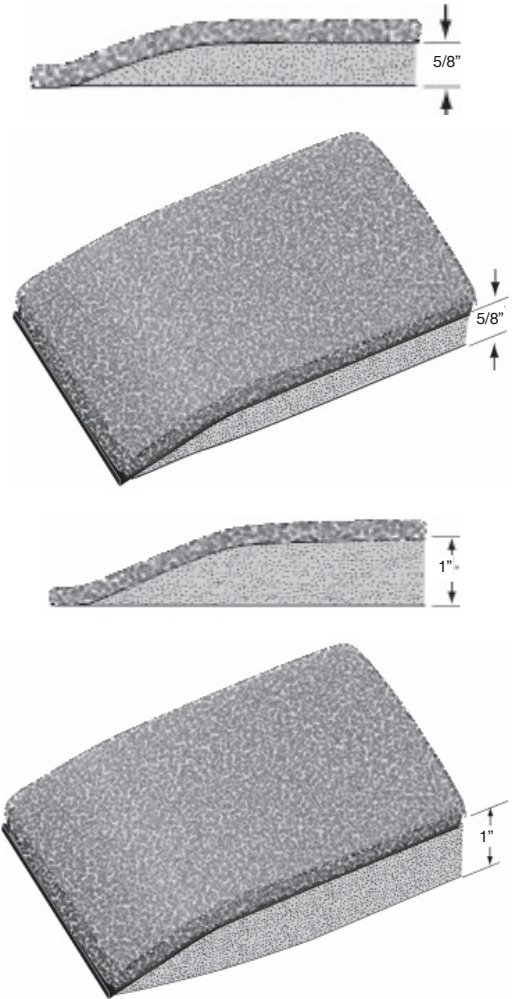

TUFF PLUSH

- Tuff Plush has maintained popularity for many years and remains a favorite in commercial settings, Retail, Banks, Pharmacies, Mail Rooms, Service Counters, etc.
- Now available in nine colors to match any decor, Tuff Plush is as comfortable as it is aesthetically pleasing.
- Do not let the elegant look of this mat fool you. Tuff Plush provides resistance to punctures from heels, cart traffic tears and cuts and is permanently bonded to the same closed cell polymeric sponge base as our industrial grade mats.
- Easily cleaned with a vacuum.
- Tuff Plush mats are available in two styles. The single sponge style is 5/8" thick and the double sponge is a full 1" thick.
- Edges of sponge base will be beveled to within 2" of top surface to effectively taper the edges of the surface to the floor and create a visibly molded incline around the perimeter of the mat.



Blue



Charcoal



Beige



Solid Navy



Red/Black



Hunter Green



Walnut

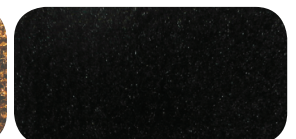

Solid Black



Solid Gray

TUFF PLUSH MATS			
For 1" mats, add "DS" to stock number			
Stock No.	Sizes	Wt. Ea. 5/8"	Wt. Ea. 1"
TP-2434	24" x 34"	8.4 lbs.	9.6 lbs.
TP-3460	34" x 60"	21.0 lbs.	24.0 lbs.
CUSTOM SIZES-available in lengths up to 60 lin. Ft.			
Stock No.	Widths	Wt./Lin. Ft. 5/8"	Wt./Lin. Ft. 1"
TP-34	34"	4.2 lbs.	4.8 lbs.
TP-44	44"	5.6 lbs.	6.4 lbs.
TP-68	68"	8.4 lbs.	9.6 lbs.
Colors: Beige, Blue, Charcoal, Hunter Green, Solid Black, Solid Gray, Walnut, Red/Black, Solid Navy.			
1" Thick Double Sponge (DS). 3% Variance.			





MULTI-FLEX ANTI-FATIGUE

- The Multi-Flex combination of a Performance Rated Polymeric top surface with a Multi-Flex sponge base provide the simplest and most effective way to reduce standing fatigue and stress.
- This engineered top surface is extremely durable providing resistance to punctures from heels, cart traffic, tears and cuts. At the same time the surface remains soft and pliant allowing exceptional sensitivity to the Multi-Flex sponge base.
- Multi-Flex is a super resilient polymeric sponge base with staggered air channels that create a unique multi-density surface. This encourages subtle weight shift and movement of leg and calf muscles which in turn promotes blood flow, resulting in improved circulation and reduced fatigue.
- Improving your circulation and muscle tone reduces the risk of developing varicose veins or increasing the severity of an existing condition. Remember that good circulation is the essence of a healthful life.
- Multi-Flex Anti-Fatigue mats are a full 7/8" thick, double the thickness of ordinary mats.
- Three year, conditional non-prorated warranty insures against cracking or fracturing.
- Patent pending.

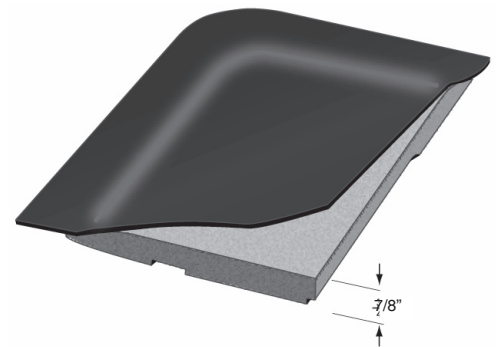

BLACK GLOSSY

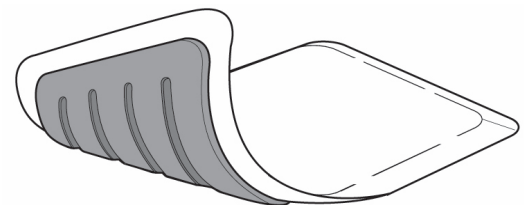

MULTI-FLEX Anti Fatigue Mats

Stock No.	Size	Weight Ea.
MF-2436	2' x 3'	9.0 lbs
MF-3660	3' x 5'	23.0 lbs
MF-310	METALLIC 3' x 10'	45.0 lbs
MF-320	3' x 20'	90.0 lbs
CUSTOM SIZES – available in Lengths up to 75 Ln. Ft.		
Stock No.	Widths	Weight/ Lin.Ft.
MF-36	36"	4.5 lbs
MF-48	48"	6.0 lbs
Color: Black Only. 7/8" Thick.		



EASY KLEEN Anti-fatigue Mats

EASY KLEEN ANTI-FATIGUE

- Wide ribbed vinyl surface ensuring quick and easy removal of dirt and debris from mats.
- 1/8" thick round ribbed vinyl surface with a resilient closed cell polymeric sponge base.
- Your choice of 1/2" or 7/8" overall thickness.

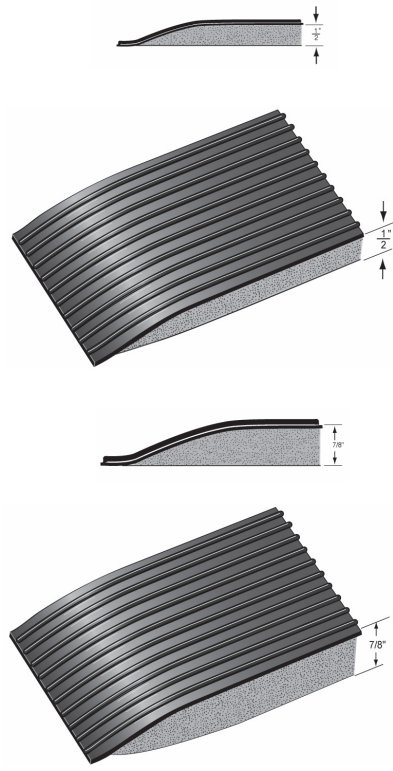

EASY KLEEN ANTI-FATIGUE MATS

For 7/8" mats, add "DS" to stock number

Stock No.	Sizes	Wt. Ea. 1/2"	Wt. Ea. 7/8"
ETT-2434	24" x 34"	8.0 lbs.	9.0 lbs.
ETT-3660	34" x 60"	16.0 lbs.	19.0 lbs.

CUSTOM SIZES-available in lengths up to 60 lin. Ft.

Stock No.	Widths	Wt./Lin. Ft. 1/2"	Wt./Lin. Ft. 7/8"
ETT-24	24"	2.2 lbs.	2.6 lbs.
ETT-36	36"	3.3 lbs.	3.9 lbs.
ETT-48	48"	4.4 lbs.	5.2 lbs.

Colors: Black.

7/8" Thick Double Sponge (DS).



CORRUGATED Anti-fatigue Mats

CORRUGATED ANTI-FATIGUE

- Corrugated top anti-fatigue mats have been around for many years and remain a favorite in commercial and industrial environments.
- Corrugated anti-fatigue offers the quality of a laminated product at a price point that is sure to fit any budget.
- 1/8" thick corrugated top laminated to a 3/8" closed cell polymeric sponge base, overall thickness 1/2" or 7/8".

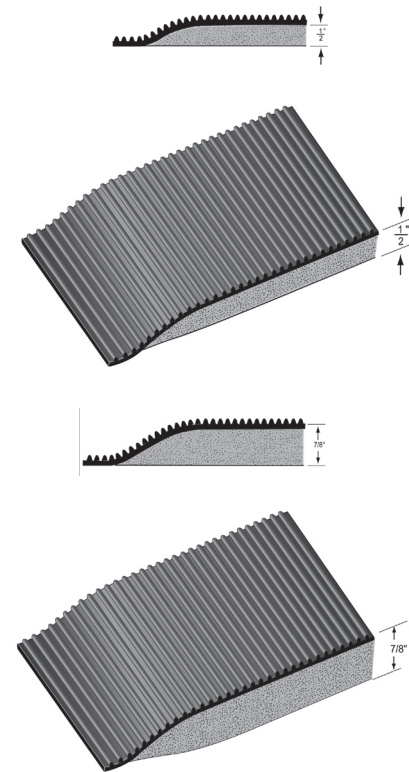

CORRUGATED ANTI-FATIGUE MATS

For 7/8" mats, add "DS" to stock number

Stock No.	Sizes	Wt. Ea. 1/2"	Wt. Ea. 7/8"
CTT-2434	24" x 34"	8.0 lbs.	9.0 lbs.
CTT-3660	34" x 60"	16.0 lbs.	19.0 lbs.

CUSTOM SIZES-available in lengths up to 60 lin. Ft.

Stock No.	Widths	Wt./Lin. Ft. 1/2"	Wt./Lin. Ft. 7/8"
CTT-24	24"	2.2 lbs.	2.6 lbs.
CTT-36	36"	3.3 lbs.	3.9 lbs.
CTT-48	48"	4.4 lbs.	5.2 lbs.

Colors: Black, Black/Yellow.

7/8" Thick Double Sponge (DS).



HDT-ANTI FATIGUE MAT

- HDT-Anti Fatigue was developed to give assembly line personnel a mat that stools or chairs with casters could be used on. The product has also found a niche in laboratories and the retail sector for use in pharmacies.
- The top surface of HDT-Anti Fatigue is made from the same exceptionally durable compound as our Diamond Plate product except it's 3/16" thick with a smooth surface.
- This puncture proof surface material combined with our closed cell polymeric sponge base creates a mat to withstand the most rigorous commercial environments.
- HDT offers excellent durability and long life, suffers no deterioration from weathering, ozone exposure and is self-extinguishing when tested in accordance with FMVSS-302.
- HDT-Anti Fatigue Mats are available in two styles. The Deluxe version is 9/16" thick and the Super Deluxe version is 1" thick. Both versions are available in individual mats or full roll lengths of 24", 36", 48", 60", and 72" widths.
- Edges of sponge base will be beveled to within 2" of the top surface to effectively taper the edges of the surface to the floor and create a visibly molded incline around the perimeter of the mat.
- 5 year warranty.

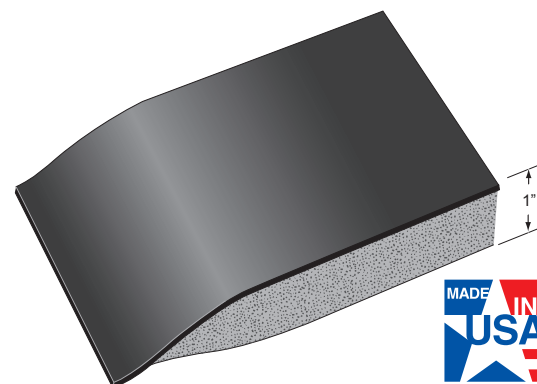
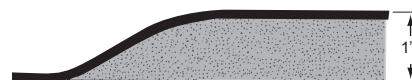
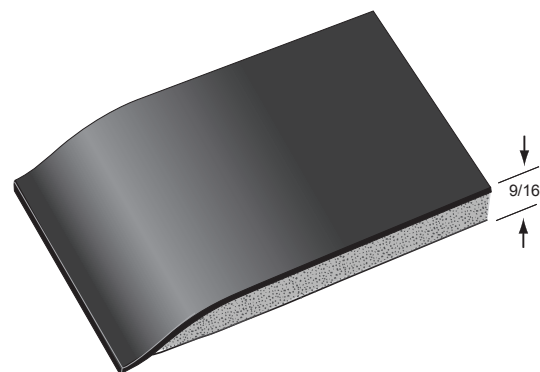
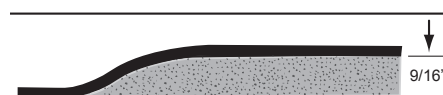

HDT-ANTI FATIGUE				
For 1" mats, add "DS" to stock number				
Stock No.	Sizes	Weight Ea. 9/16"	Weight Ea. 1"	
HDT-2436	24" x 36"	6.8 lbs.	8.0 lbs.	
HDT-3660	36" x 60"	17.0 lbs.	20.0 lbs.	
CUSTOM SIZES – available in lengths up to 75 lin. Ft.				
Stock No.	Widths	Wt./Lin. Ft. 9/16"	Wt./Lin Ft. 1"	
HDT-24	24"	2.4 lbs.	2.6 lbs.	
HDT-36	36"	3.4 lbs.	4.0 lbs.	
HDT-48	48"	4.8 lbs.	5.64 lbs.	
HDT-60	60"	6.0 lbs.	7.1 lbs.	
HDT-72	72"	6.8 lbs.	8.0 lbs.	
Color: Black 1" Thick/Double Sponge (DS)				





COMFORT*CRAFT CHECK-STAND MATS

- Comfort Craft mats are rated first in comfort because of the premium Polyurethane sponge compound used in manufacturing. The integral skin process totally encapsulates the 3/4" thick mat in an 1/8" skin that is chemical and abrasion resistance with a lay-flat beveled edge.
- Comfort Craft's crush-resistant sponge provides optimal balance in between compression and resistance which absorbs shock while providing the necessary support for stability.
- Recommended for 24/7 use at check-stands, laboratories, industrial or pharmacies.
- Comfort Craft mats transform standing personnel performance by making the job more comfortable and enjoyable.

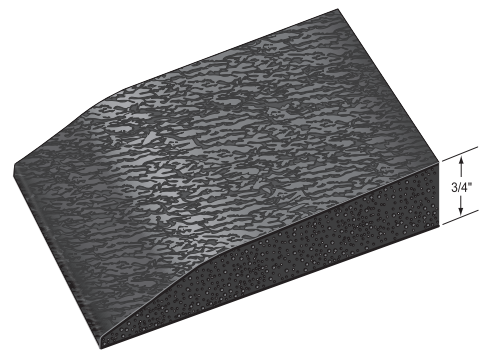

COMFORT CRAFT 3/4"		
Stock No.	Size	Weight Ea.
CC-1824	18" x 24"	3.0 lbs.
CC-2436	2' x 3'	6.0 lbs.
CC-2448	2' x 4'	8.0 lbs.
CC-2472	2' x 6'	12.0 lbs.
CC-4848	4' x 4'	18.0 lbs.
CC-4860	4' x 6'	27.2 lbs.
CC-3660	3' x 5'	17.0 lbs.

Color: Black. 3/4" Thick.





COMFORT CRAFT EXPRESS

- Rhino mats newly developed Low-Pro domed surface delivers the superior ergonomics that can only be achieved with a Bi-Level surface, with smooth surface cleanability.
- The Comfort Craft Express has a near perfect underfoot contour, offers a faster adapting surface, slightly springy feel and delivers premium ergonomics and much needed relief the standing worker deserves.
- Comfort Craft Express is a 7/8" thick polyurethane sponge mat encapsulated in an unbelievably tough and wear resistant 1/8" thick solid polyurethane skin.
- When the job demands standing, there are "no substitutions" for a world class anti-fatigue mat like Comfort Craft Express.
- Sizes available 2'X3', 2' x 4', and 3'X5'. Color: Black.

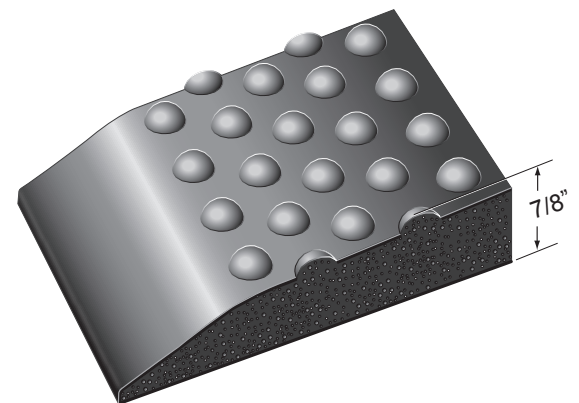

COMFORT CRAFT EXPRESS 7/8"		
Stock No.	Size	Weight Ea.
PF-2436	2' x 3'	6.0 lbs.
PF-2448	2' x 4'	8.0 lbs.
PF-3660	3' x 5'	15.0 lbs.
Color: Black. 7/8" Thick.		





GRANDSTAND™ Anti-Fatigue Mats

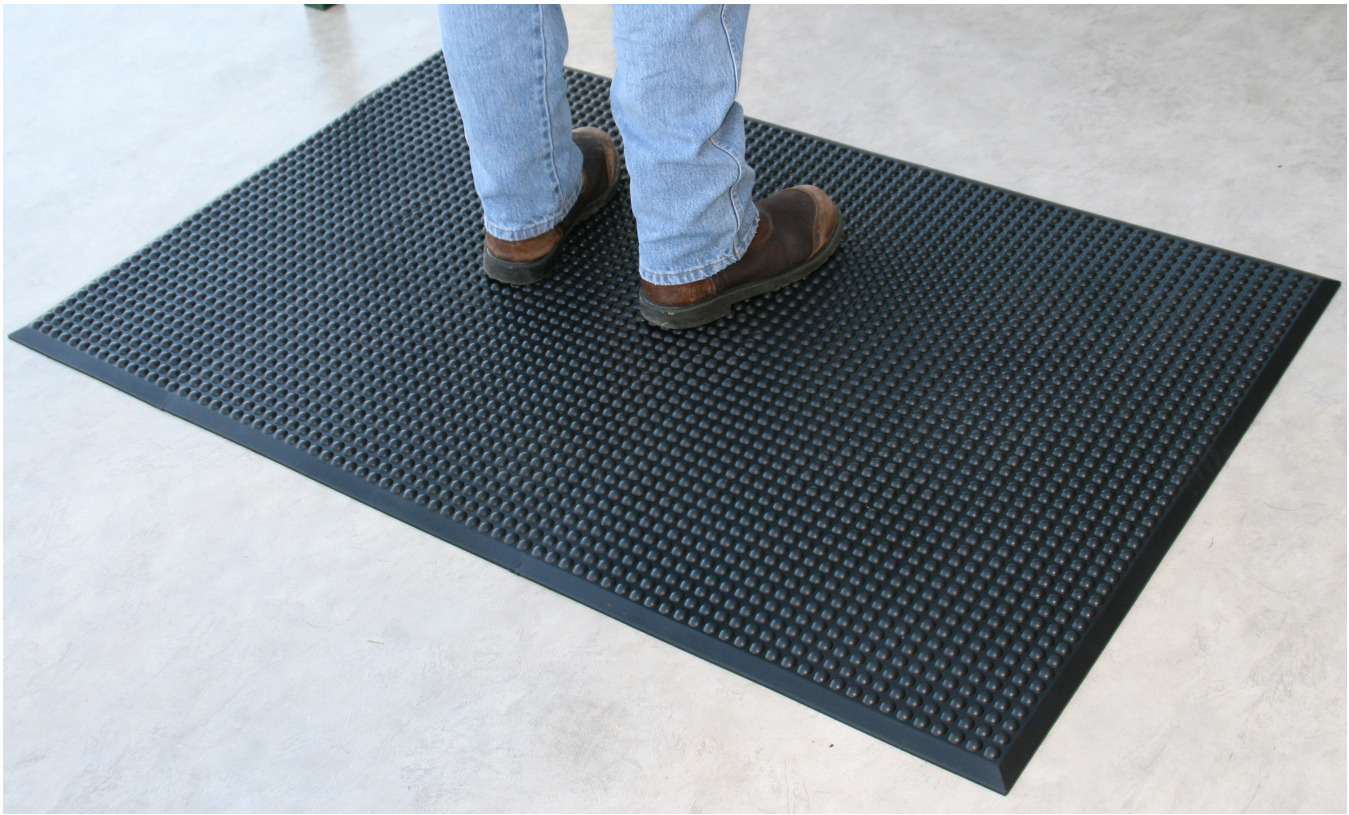

GRANDSTAND

- Part of adjusting to the New Normal, is accommodating older personnel. By 2018, people 55 or older will account for 25% of the workforce and demographics show, we don't have enough younger people to replace those valuable skills and experience.
- Grandstand was developed to provide the ultimate solution for reducing or eliminating short term fatigue and discomfort. The elastic properties of the Integral Skin Polyurethane sponge in combination with the domed top surface, give GrandStand a buoyancy and bounce that resemble the natural springiness of walking on a fresh mowed lawn.
- Grand Stand's polyurethane construction provides beveled edges that will never curl up and is available in one piece construction in almost any size and shape.
- Ideal in industrial, laboratory, pharmaceutical, commercial environments, individual check stands or any large areas.
- Stock sizes are 2x3 and 3x5.

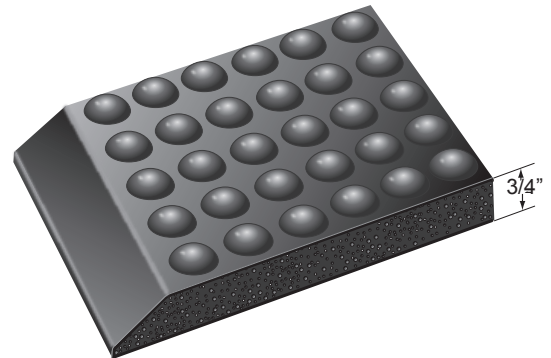

GRANDSTAND 3/4"		
Stock No.	Size	Weight Ea.
GS-2436	2' x 3'	6.0 lbs.
GS-3660	3' x 5'	19.0 lbs.

Color: Black. 3/4" Thick.





COMFORT*CRAFT DIAMOND

- Comfort*Craft Diamond Plate raises the bar considerably and offers an American made 100% recyclable, industrial grade polyurethane diamond plate anti-fatigue mat with durability that confirms it's recognition as the best environmental solution available in the market place.
- The Comfort*Craft Diamond Plate is a unique product that incorporates an integral 1/8" skin envelope process that totally encapsulates the 3/4" thick mat and is chemical and abrasion resistant with guaranteed lay-flat beveled edges.
- The unique properties of Polyurethane sponge provides optimal balance in-between compression and resistant while providing the necessary support for stability.
- Comfort*Craft Diamond Plate mats are solid black, 3/4" thick. available in stock sizes, 2x3 and 3x5
- United States Patent and Trademark Office # 29/440797

COMFORT*CRAFT DIAMOND 3/4"		
Stock No.	Size	Weight Ea.
CCD-2436	2' x 3'	6.0 lbs.
CCD-3660	3' x 5'	20.0 lbs.
Color: Black. 3/4" Thick.		

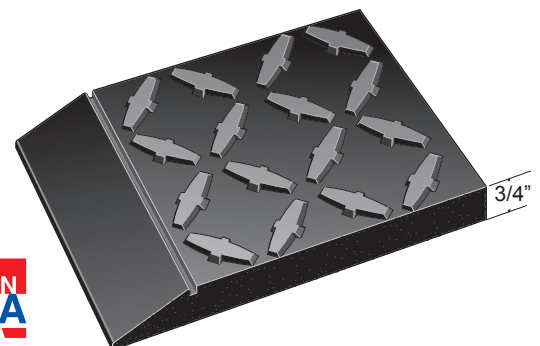



DIAMOND-TRED® Anti-Fatigue Mats

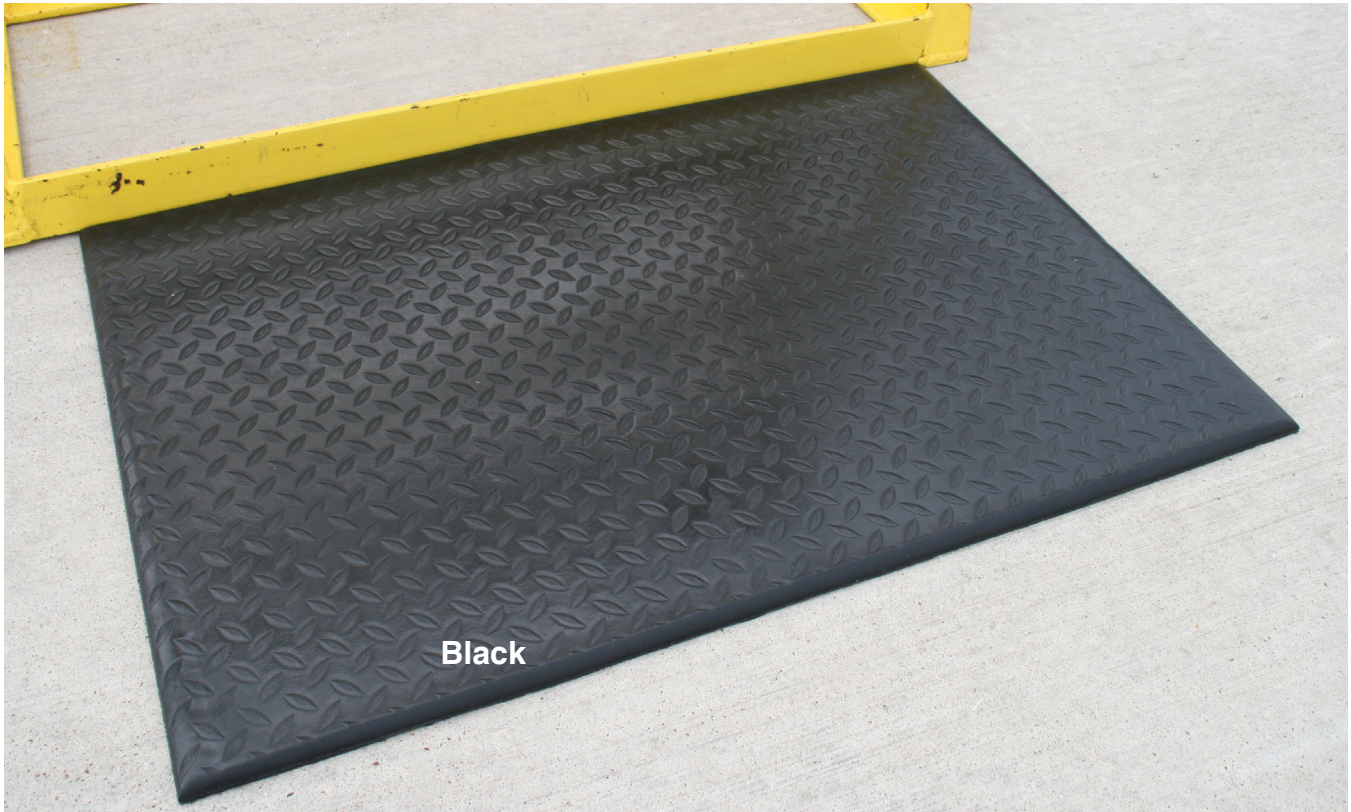

DIAMOND-TRED

- Not to be confused with our Diamond Plate Anti-fatigue, Diamond-Tred is another cost saving product from Rhino mats that offers surprising comfort and value.
- A durable, integrated slip-resistant wear layer of high-density vinyl foam polymerically bound to a soft, moisture-resistant closed-cell vinyl sponge through Rhino's unique unibond process.
- Resistant to degradation by inorganic acids, organic acids, reducing agents, detergent solutions, alcohols, aliphatic hydrocarbons, mineral oil, amines, and aldehydes.
- All mats have a 1/10" wear surface laminated to a 1/2" sponge base and are approximately 9/16" thick. Diamond-Tred is available in full 60 foot rolls or cut lengths with bevel edges on cut ends.

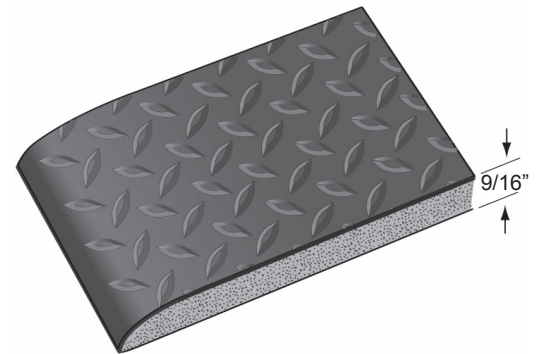
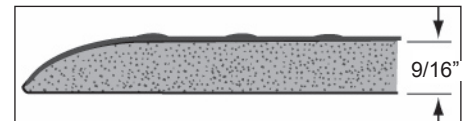

DIAMOND-TRED MATS 9/16" THICK		
Stock No.	Sizes	App. Wt.
DT-2436	24" x 36"	6.0 lbs.
DT-3660	36" x 60"	12.0 lbs.
DIAMOND-TRED ROLLS & CUT LENGTHS		
Stock No.	Sizes	App. Wt./lin.ft.
DT-36	3' x 60'	3.0 lbs.
DT-48	4' x 60'	4.0 lbs.
DT-60	6' x 60'	6.0 lbs.
Color: Black only. 9/16" Thick.		



DURA STEP

- The new Dura Step anti-fatigue mat combines technology and craftsmanship in an exclusive 2-layer construction.
- A durable embossed wear surface of vinyl is polymerically integrated with a moisture resistant, closed cell vinyl sponge base.
- The advanced dual action performance of the Dura Step mat provides safety, comfort and a long duty cycle in a matting product that is superior to standard single-layered foam mats.
- This exclusive manufacturing technique combines a 3/32" embossed wear surface with a 3/8" closed-cell soft sponge base layer, creating an overall thickness of approx. 1/2 inch.
- Durable beveled edges on all four sides provide users with a lay-flat safety border insuring smooth surface to surface transition.
- Dura Step Anti-Fatigue Mats are 1/2" thick.

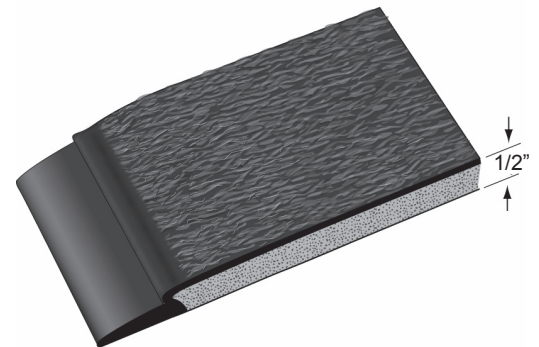
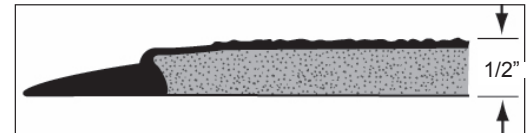

DURA STEP ANTI-FATIGUE MATS 1/2" THICK

Stock No.	Sizes	App. Wt.
DS-2436	24" x 36"	7.0 lbs.
DS-3660	36" x 60"	15.0 lbs.

DURA STEP ROLLS & CUT LENGTHS

Stock No.	Sizes	App. Wt./lin.ft.
DS-24	2' x 60'	2.0 lbs.
DS-36	3' x 60'	3.0 lbs.
DS-48	4' x 60'	4.0 lbs.

Color: Black only. 1/2" Thick.





COMFORT STEP™ TEXTURED Anti-Fatigue Mats



COMFORT STEP TEXTURED

- Fatigue fighting floor mats and matting feature 3/8" or 5/8" thick closed cell vinyl foam.
- Beveled edges minimize risk of tripping and stumbling.
- Pebble-textured top surface provides sure footing.
- Helps boost productivity by relieving fatigue caused by long standing.
- Also serves to muffle distracting noises...protects feet from cold drafty floors.

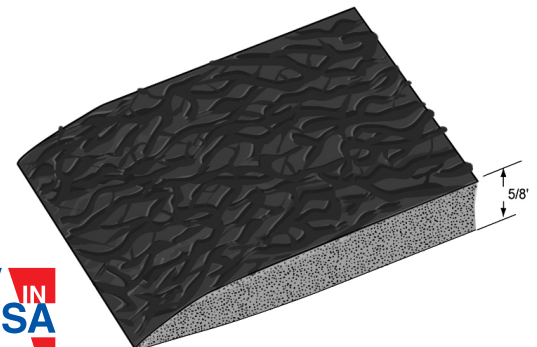
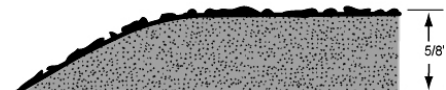
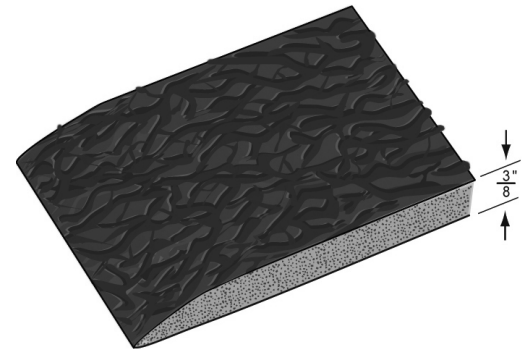
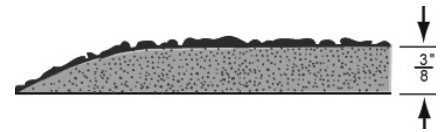

COMFORT STEP TEXTURED MATS 3/8" THICK		
Stock No.	Sizes	App. Wt.
CST-2436	24" x 36"	4.6 lbs.
CST-2460	24" x 60"	7.7 lbs.
CST-3660	36" x 60"	10.2 lbs.
CST-310	36" x 120"	20.4 lbs.
CST-4872	48" x 72"	16.3 lbs.
COMFORT STEP TEXTURED MATTING 3/8" THICK		
Stock No.	Sizes	App. Wt./lin.ft.
CST-24	2' x 60'	1.5 lbs.
CST-36	3' x 60'	2.0 lbs.
CST-48	4' x 60'	2.6 lbs.
Colors: Black, Gray.		
COMFORT STEP TEXTURED 5/8" THICK		
Stock No.	Sizes	App. Wt./lin.ft.
CST-330	3'X60'	3.4 lbs.
CST-430	4'X60'	4.5 lbs.
Colors: Black, Gray.		



COMFORT STEP SAFETY

- Textured surface provides slip-resistant footing. Beveled edges help prevent tripping.
- Bright yellow borders increases safety awareness.
- 3/8" thick closed cell vinyl foam relieves leg and back fatigue and increases productivity.

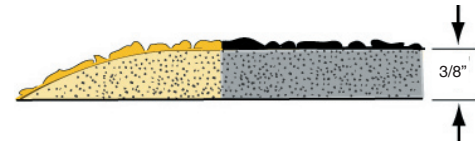

COMFORT STEP SAFETY MATS 3/8" THICK		
Stock No	Sizes	App. Wt.
CSS-2436	24" x 36"	4.6 lbs.
CSS-3660	36" x 60"	10.2 lbs.
CSS-310	36" x 120"	20.4 lbs.
CSS-4872	48" x 72"	16.3 lbs.
COMFORT STEP SAFETY MATTING 3/8" THICK		
Stock No	Sizes	App. Wt./Lin.ft.
CSS-24	2' x 60'	1.5 lbs.
CSS-36	3' x 60'	2.0 lbs.
CSS-48	4' x 60'	2.6 lbs.
Colors: Black with Yellow Borders. 3/8" Thick.		

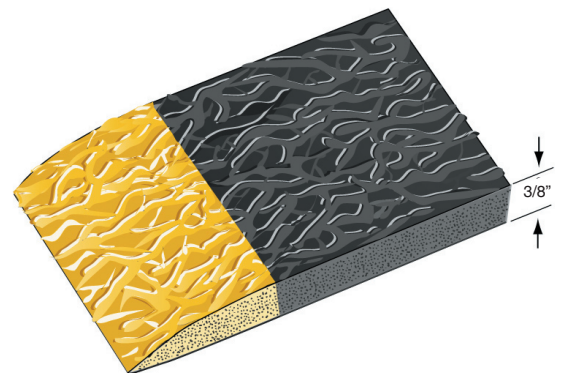



ULTRA-DOME™ WORKSTATION Anti-Fatigue

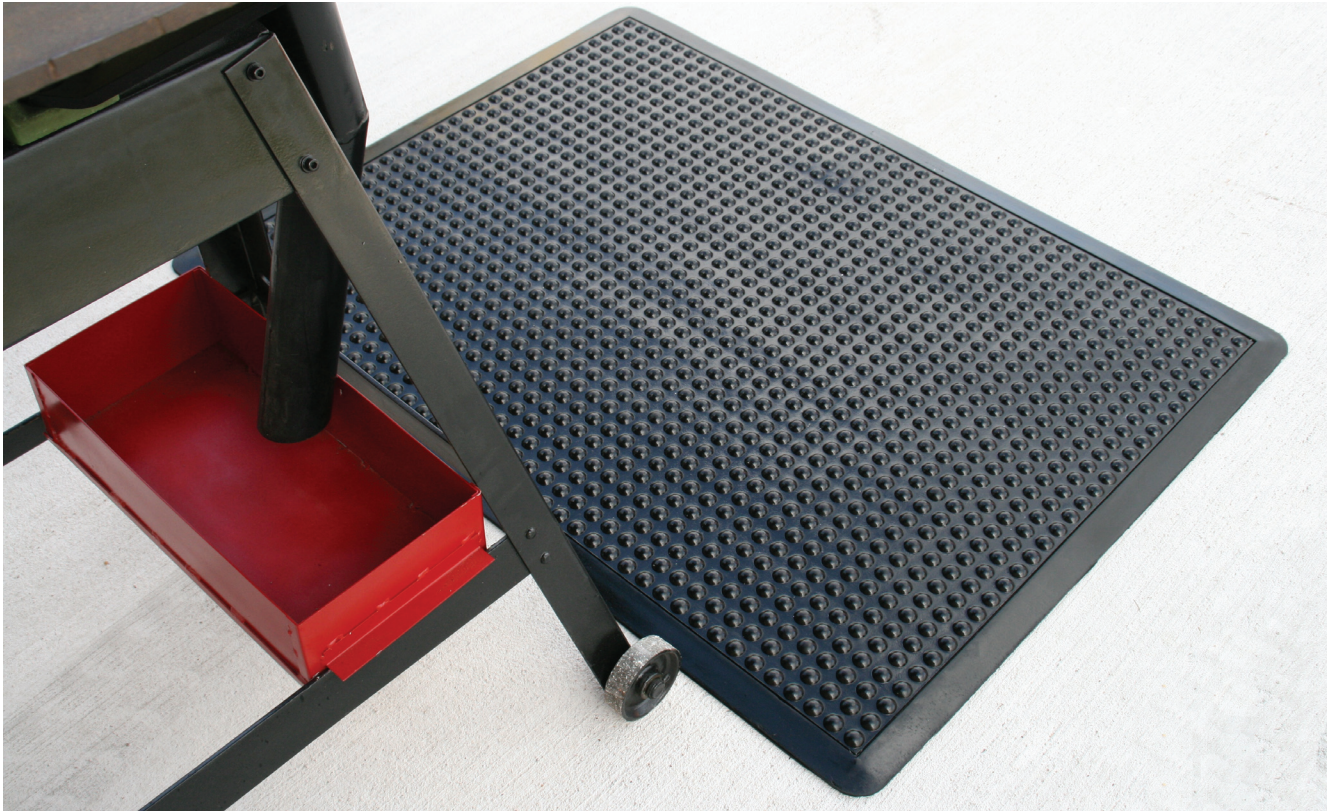

ULTRA-DOME WORKSTATION MAT

- Designed for worker comfort, Ultra-Dome's unique hollow dome design encourages frequent yet subtle changes in posture, inducing natural flexing of muscles, thus reducing the build-up of lactic acid that causes fatigue.
- Perfect as a single station work-area mat, check stands, assembly stations and convenience stores.
- Single piece molded beveled borders on all four sides allow easy access.
- Ultra-Dome mats are manufactured with tree derived rubber, harvested from the Para rubber tree.
- Thickness 1/2", 2X3s and 3X4s are solid back.

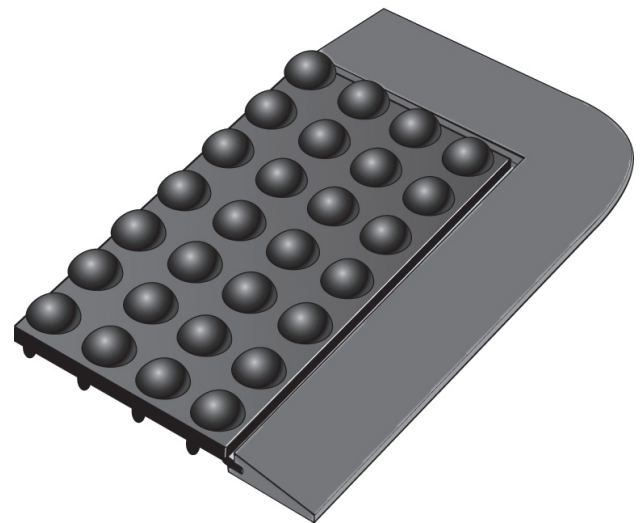

ULTRA-DOME ANTI-FATIGUE MATS			
Stock No.	Description	Sizes	Weight Ea.
UD2436	Black	2' x 3'	10.0 lbs.
UD3648	Black	3' x 4'	20.0 lbs.
Colors: Black.			
1/2" Thick, Bevel 4 sides.			



TRITAN® ULTRA-DOME® ROLLS ANTI-FATIGUE

- The Ultra-Dome advantage is the distance the domed surface provides between slag/sparks/hot metal shavings and the standing worker's shoe soles,
- Ultra-Dome's combination of domed surface with evenly spaced compression knobs on the underside, provide a resilient and active surface with excellent anti-slip characteristics
- Ultra Dome is part of the Tritan family of products and is manufactured from recycled trim rubber from the tire manufacturing plants of Pirelli* and Michelin*, both iconic brands renowned for formulating the best rubber compounds in the world.
- Tritan stands up to caustic soda, nitric, sulfuric and hydrochloric acids, methyl alcohol, mineral oil and ethylene glycol. Tritan shows no signs of deterioration at 400 degrees Fahrenheit and no visible fractures or cracks at -45 degrees Fahrenheit.
- Ultra-Dome is available in 60 foot rolls or cut lengths. Thickness: 5/8"

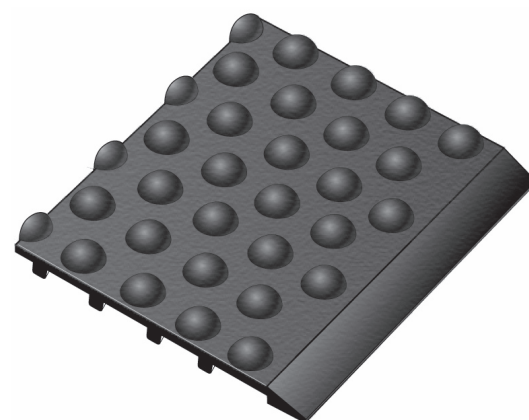

TRITAN ULTRA-DOME ANTI-FATIGUE CUT ROLLS		
Stock No.	Size	Weight Ea.
UDR3660	36" x 60"	23.0 lbs.
UDR310	36" x 120"	45.0 lbs.
TRITAN ULTRA-DOME ANTI-FATIGUE ROLLS		
Stock No.	Size	App. Wt./Lin.ft.
UDR36	3' x 60'	4.5 lbs.
Colors: Solid Black only. 5/8" Thick		



K-SERIES Solid Cushion Mats



K-SERIES SOLID

- The K-Series Solid Top features a Diamond surface pattern for sure footing and is ideal for industrial applications, weight rooms, ice skating arenas or any place where a combination of floor protection and standing or walking comfort is needed. It provides easy on off movement of wheeled equipment.
- Solid Top mats have the K-Series hidden inter lock system that allows the build-out of virtually any size or configuration, with male connectors on two sides and female connectors on two sides of the mat, no accessory connectors are needed.
- Solid Top mats will not pull apart and easily unlock when needed.
- For on-site custom configurations The K-Series ramp system comes in male & female configurations with an interlocking end tab for interlocking two adjoining ramps for a secure and professional look.
- K-Series mats are manufactured with natural tree rubber from the Para rubber tree. It has less impact on the environment, it is an ecologically sustainable crop and contributes to the maintenance of the global carbon balance in the atmosphere.
- Solid Top mats contain a Nitrile polymer for added resistance to machine cutting fluids and acids.
- 3'X3' size with connecting black or yellow bevels, Thickness 7/10".



K-SERIES SOLID DIAMOND Cushion Mats		
Stock No.	Description	App. Wt.
KS-3636SD	36" x 36" X .7" Diamond Top mat	20 lbs.
K-36MY	36" bevel strip male yellow	1.5 lbs.
K-36F	36" bevel strip female black	1.5 lbs.
K-36FY	36" bevel strip female yellow	1.5 lbs.
K-40M	40" corner bevel male black	1.8 lbs.
K-40MY	40" corner bevel strip male yellow	1.8 lbs.
K-40F	40" corn. bevel strip female black	1.8 lbs.
K-40FY	40" corn. bevel strip female yellow	1.8 lbs.

Colors: Black mats, Black or Yellow bevels.
Thickness: Smooth 5/8". Diamond 7/10"

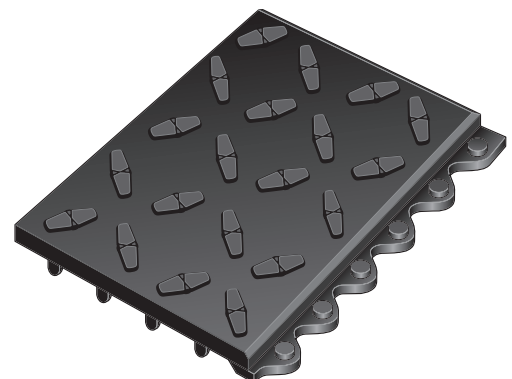



M-PACT MATS

- Tritan M-Pact Mats are a tough, durable combination of nylon fibers and rubber, that are designed to withstand the deliberate, repetitive dropping of weights in gyms, metal working facilities, manufacturing environments, steel warehousing and are also used in horse stalls & trailers and dairy farms.
- M-Pack mats are part of the Tritan series of products, that are manufactured from recycle trim rubber from the tire manufacturing plants of Pirelli® and Michelin®. Both iconic brands renowned for formulating the best rubber compounds in the world. Our utilization of these materials enables us to offer a five year guarantee.

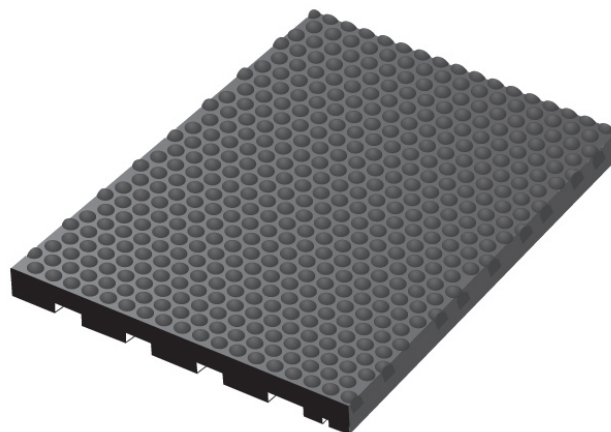

TRITAN M-PACT MATS – 1/2” THICK		
Stock No.	Sizes	App. Weight
TFS4872	4' x 6'	80 lbs.
Color: Black only. 5/8” thick.		





REFLEX CONDUCTIVE Anti-Fatigue Mats

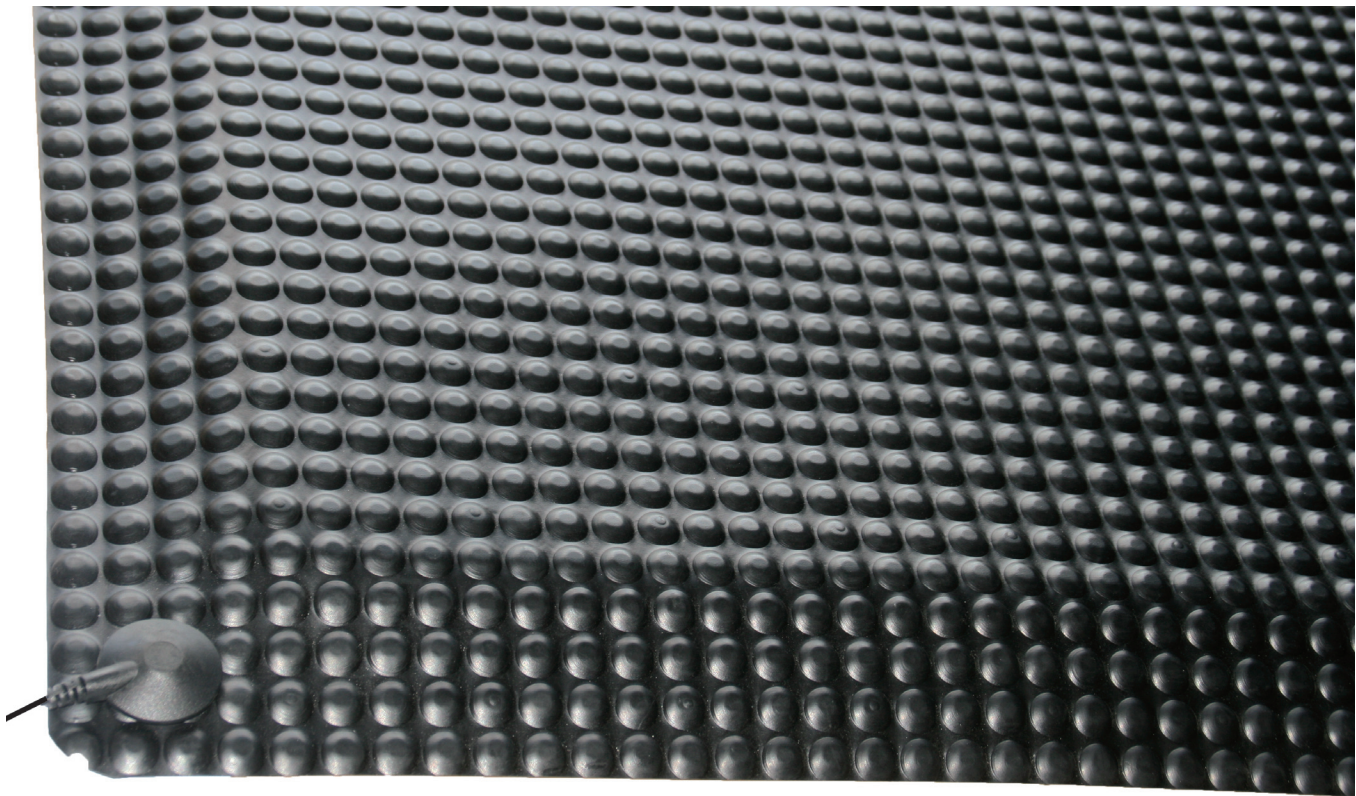

REFLEX CONDUCTIVE ANTI-FATIGUE MATS

- Reflex Anti-fatigue mats blend of resilient sponge base with a unique molded domed surface provide the simplest and most effective way to reduce standing worker fatigue and dissipate static electricity before it can be a problem.
- The domed surface of the mat provides a simple manipulation of areas of the feet. This in turn relieves tension and breaks up patterns or stress in other parts of the body to an amazing extent.
- Resistivity: Less than 10^6 OHMS, test method ESD-5.7.1 1994
- Reflex Anti-Fatigue mats are available in two styles. The Heavy Duty style is 5/8" thick and the Super Duty is a full 1" thick. Both styles are available in individual mats or full roll lengths of 24", 36" and 48" widths. All edges are beveled and sealed for safety and durability.
- Conductive matting should always be used with a ground cord.
- Use ground cord AA-107 to connect all ESD mats to a building ground or an electrical outlet, using the screw that secures the outlet cover as the attachment point.
- Patent D543765.

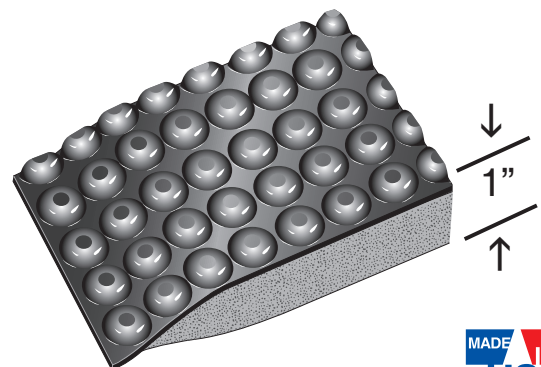
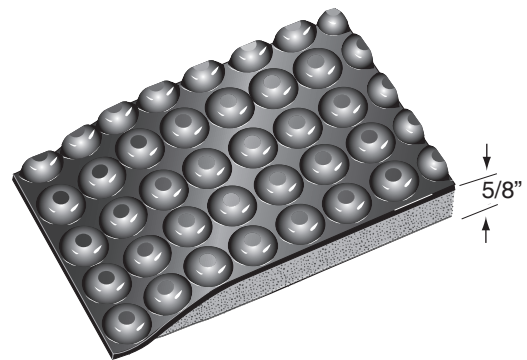

REFLEX ELECTRICALLY CONDUCTIVE ANTI-FATIGUE MATS			
For 1" mats, add "DS" to stock number			
Stock No.	Sizes	Weight Ea. 5/8"	Weight Ea. 1"
RLXC-2436	2' x 3'	9.0 lbs.	12.0 lbs.
RLXC-3660	3' x 5'	23.0 lbs.	30.0 lbs.
Custom Sizes-available in lengths up to 75 lin. Ft.			
Stock No.	Widths	Wt./Lin. Ft. 5/8"	Wt./Lin. Ft. 1"
RLXC-24	24"	3.0 lbs.	3.8 lbs.
RLXC-36	36"	5.0 lbs.	6.0 lbs.
RLXC-48	48"	6.7 lbs.	8.0 lbs.
RLXC-72	72" Seamed	10.0 lbs.	12.0 lbs.
RLXC-96	96" Seamed	13.4 lbs.	16.0 lbs.

Color: Black. AA-107 Ground Cord Kit Sold Separately.



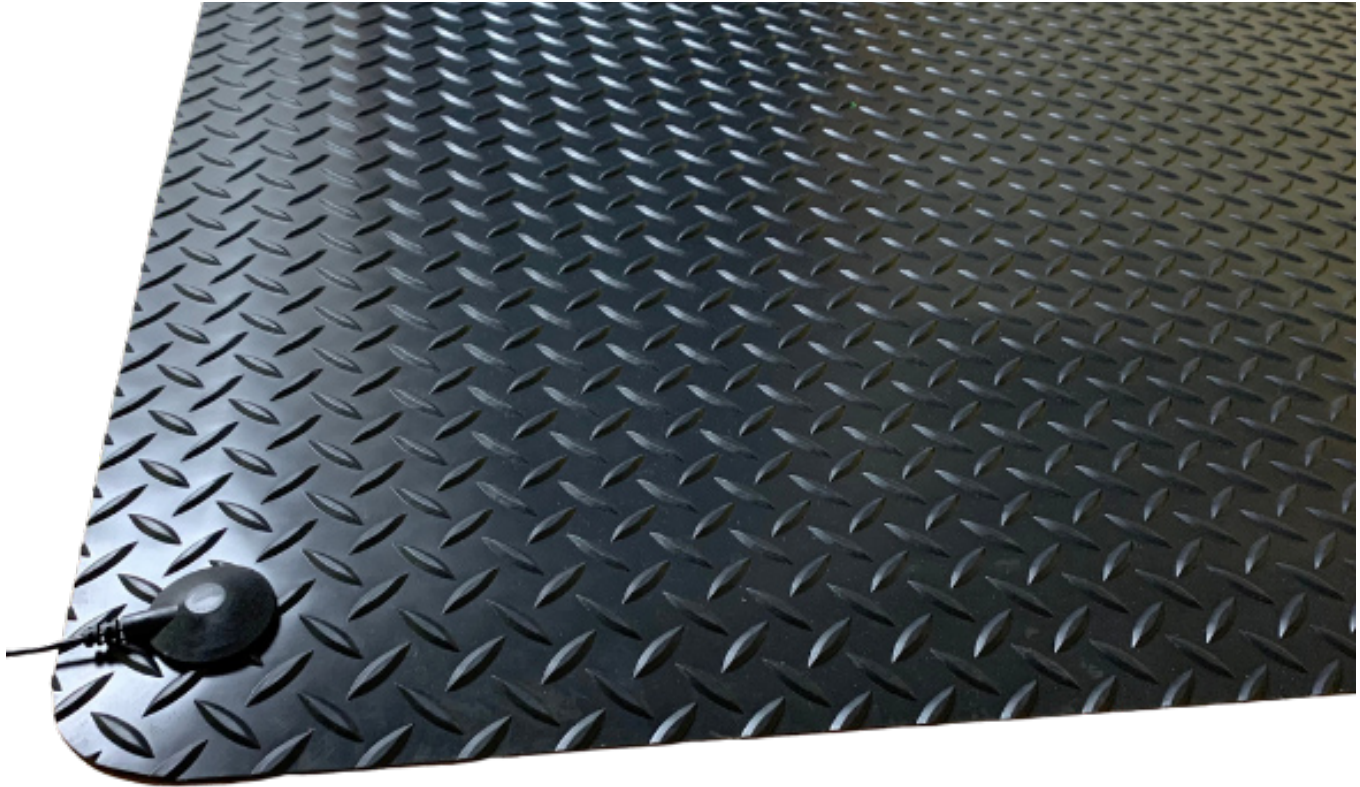

CONDUCTIVE DIAMOND PLATE ANTI-FATIGUE

- Disperse static electricity from an operator the moment they step on the mat and safely away from sensitive equipment.
- 5/32" thick electrically conductive diamond plate surface with a resilient closed cell polymeric sponge base.
- Your choice: 9/16" or 1" overall thickness with beveled edges.
- Resistivity: Less than 10⁶ OHMS, test method ESD-S7.1 1994.
- Conductive matting should always be used with a ground cord, and the surface kept clean.
- Use ground cord AA-107 to connect all ESD mats to a building ground or an electrical outlet, using the screw that secures the outlet cover as the attachment point.

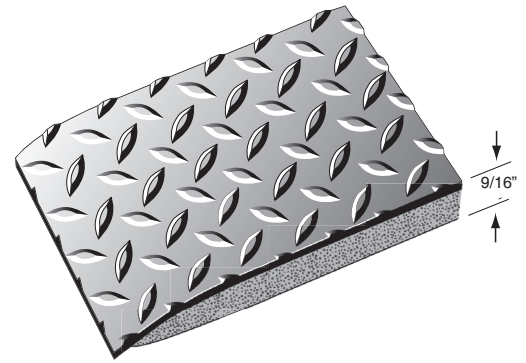

CONDUCTIVE DIAMOND PLATE ANTI-FATIGUE			
For 1" mats, add "DS" to stock number			
Stock No.	Sizes	Weight Ea. 9/16"	Weight Ea. 1"
ECD-2436TT	2' x 3'	9.0 lbs.	12.0 lbs.
ECD-3660TT	3' x 5'	23.0 lbs.	30.0 lbs.
Custom Sizes - available in lengths up to 75 lin. ft.			
Stock No.	Width	Weight/Lin.Ft. 9/16"	Wt./Lin.Ft. 1"
ECD-36TT	36"	5.0 lbs.	6.0 lbs.
ECD-48TT	48"	6.7 lbs.	8.0 lbs.
ECD-72TT	72" Seamed	10.0 lbs.	12.0 lbs.
ECD-96TT	96" Seamed	13.4 lbs.	16.0 lbs.
Color: Black. 1" Thick/Double Sponge Option. (DS)			
AA-107 Ground Cord Kit Sold Separately.			



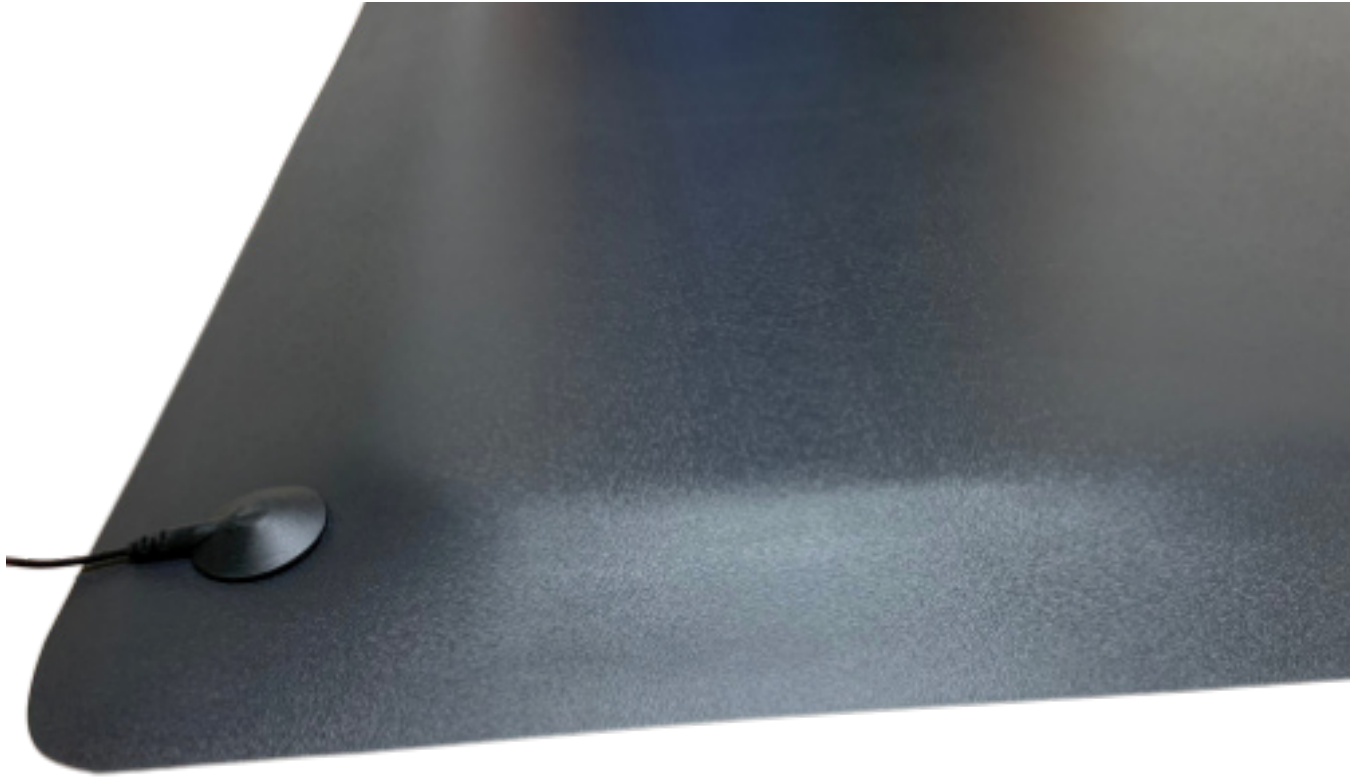

CONDUCTIVE SMOOTH TOP ANTI-FATIGUE

- Prevent the accumulation of static electricity by quickly draining it from operators and eliminate the hazards of data loss or the damaging of micro-circuitry equipment.
- 1/8" thick conductive smooth surface with a resilient closed cell polymeric sponge base.
- Your choice: 1/2" or 7/8" overall thickness with beveled edges.
- Resistivity: Less than 10^6 OHMS, test method ESD-S7.1 1994.
- Conductive matting should always be used with a ground cord, and the surface kept clean.
- Use ground cord AA-107 to connect all ESD mats to a building ground or an electrical outlet, using the screw that secures the outlet cover as the attachment point.

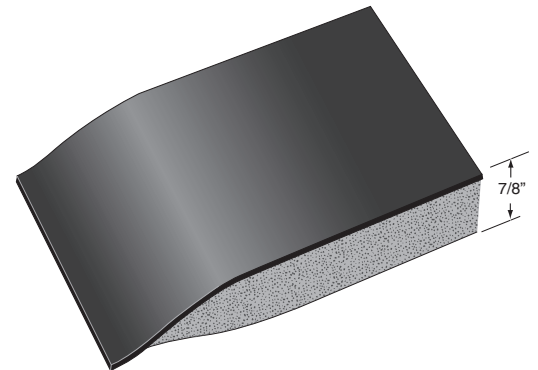
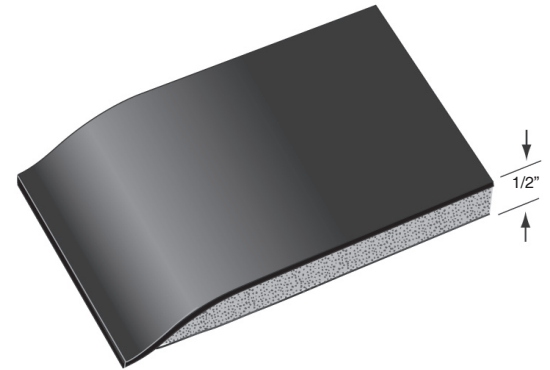

CONDUCTIVE SMOOTH TOP ANTI-FATIGUE			
For 7/8" mats, add "DS" to stock number			
Stock No.	Sizes	Weight Ea. 1/2"	Weight Ea. 7/8"
CS-2436TT	2' x 3'	9.0 lbs.	12.0 lbs.
CS-3660TT	3' x 5'	23.0 lbs.	30.0 lbs.
Custom Sizes-available in lengths up to 75 lin. Ft.			
Stock No.	Widths	Wt./Lin. Ft. 1/2"	Wt./Lin. Ft. 7/8"
CS-36TT	36"	4.5 lbs.	6.0 lbs.
CS-48TT	48"	6.0 lbs.	8.0 lbs.
CS-72TT	72" Seamed	9.0 lbs.	12.0 lbs.
CS-96TT	96" Seamed	12.0 lbs.	16.0 lbs.
Color: Black. 7/8" Thick/Double Sponge (DS)			
AA-107 Ground Cord Kit Sold Separately.			



COMFORT STEP ESD Static Dissipative Anti-Fatigue Mats



COMFORT STEP ESD STATIC DISSIPATIVE ANTI-FATIGUE MATS

- Comfort Step ESD is a budget priced static dissipative sponge vinyl, anti-fatigue mat which prevents the accumulation of damaging static in environments where ESD protection is needed.
- Comfort Step ESD is a cross-linked vinyl-nitril resilient sponge. 3/8" overall thickness with a textured top surface and beveled edges.
- Resistivity: Less than 10^9 OHMS, test method ESD-S7.1 1994.

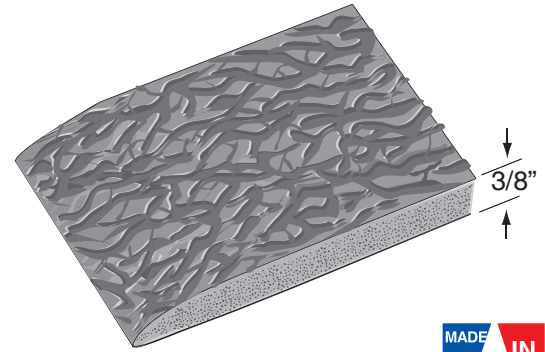

3/8" THICK STATIC DISSIPATIVE		
Stock No.	Sizes	App. Wt./Lin. Ft.
CSE-36	3' x 60'	2.7 lbs.
CSE-48	4' x 60'	3.6 lbs.
Color: Gray		

CONDUCTIVE SMOOTH RUNNER



CONDUCTIVE SMOOTH TOP WORK SURFACE AND RUNNER

- 3/32" thick conductive smooth surface.
- Resistivity: Less than 10^6 OHMS, test method ESD-S7.1 1994
- Conductive matting should always be used with a ground cord, and the surface kept clean.

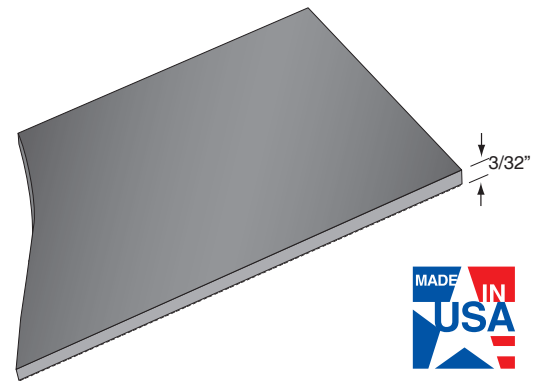

CONDUCTIVE SMOOTH TOP		
Stock No.	Sizes	Weight/Lin. Ft.
CS36	3/32" x 36" x 75'	2.70 lbs.
CS48	3/32" x 48" x 75'	3.43 lbs.
Cut lengths available up to 75' ft.		
Color: Black. 3/32" Thick.		

CONDUCTIVE DIAMOND PLATE RUNNER



CONDUCTIVE DIAMOND PLATE RUNNER

- Disperse static electricity from an operator the moment they step on the mat and safely away from sensitive equipment.
- 5/32" thick electrically conductive diamond plate surface.
- Resistivity: Less than 10^6 OHMS, test method ESD-S7.1 1994.
- Conductive matting should always be used with a ground cord, and the surface kept clean.

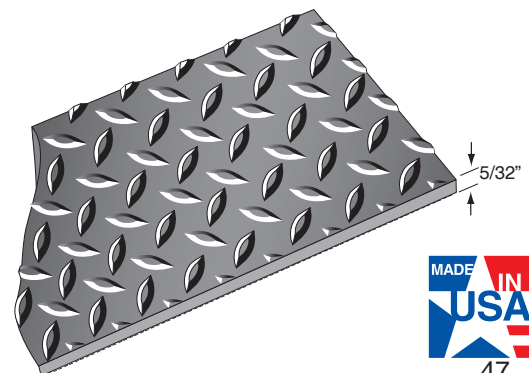
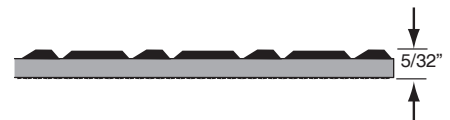

CONDUCTIVE DIAMOND PLATE RUNNER		
Stock No.	Size	Weight/Lin.Ft.
ECD36	5/32" x 36" x 75'	2.70 lbs.
ECD48	5/32" x 48" x 75'	3.43 lbs.
Cut lengths available up to 75 ft.		
Color: Black. 5/32" Thick.		



DUAL PURPOSE Dielectric Anti-Fatigue Mats



DUAL PURPOSE DIELECTRIC

- Quarter inch thick, ASTMD-178, corrugated or diamond surfaced switch-board mats laminated to a 3/8" thick, super resilient polymeric sponge base provides employees a comfortable work surface to stand on while providing protection from accidental electrical shock.
- Rhino switchboard conforms to OSHA requirements for electrical protective devices with certification engraved on back.
- Rhino Dual-Purpose switch board matting also meets the optional requirements cited by ASTM for flame resistance, ozone resistance and oil resistance.

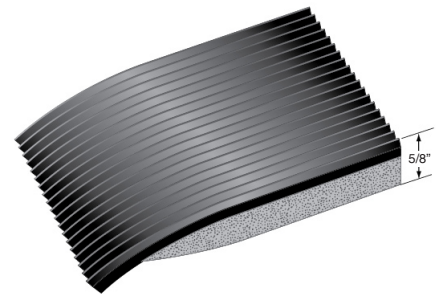

AVAILABLE IN CORRUGATED OR DIAMOND SURFACE

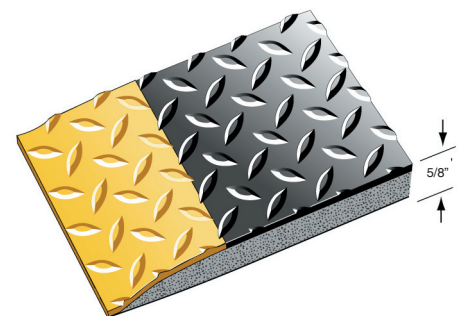

DUAL PURPOSE DIELECTRIC ANTI-FATIGUE

Stock No.	Sizes	App. Wt.
DP-2436	2' X 3'	15.0 lbs.
DP-3648	3' X 4'	30.0 lbs.
DP-3660	3' X 5'	37.5 lbs.

DUAL PURPOSE CUT LENGTHS

Stock No.	Sizes	App. Wt./lin.ft.
DP-36	3' x 75'	7.5 lbs.
DP-48	4' x 75'	10.0 lbs.

Color: Black. Yellow edes on Diamond Surface only. For Diamond surface, add the letter "D".
5/8" Thick.



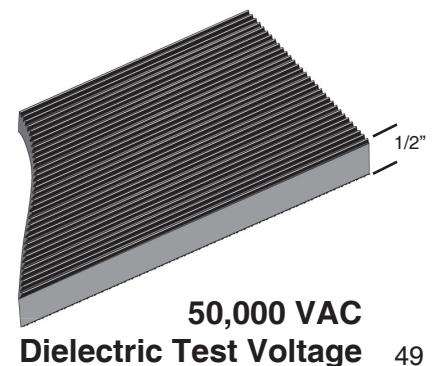
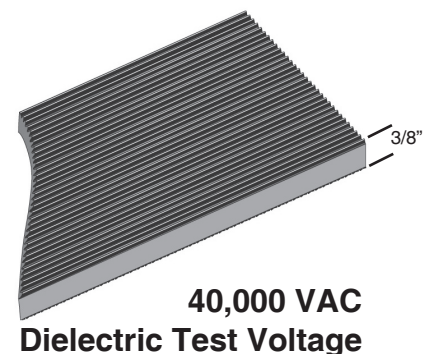
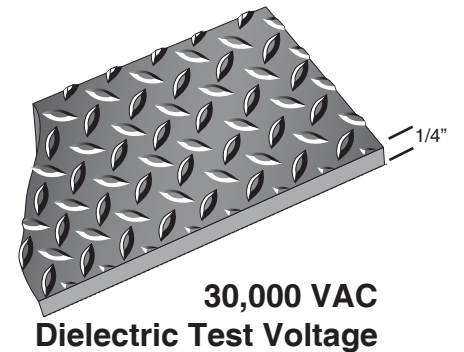
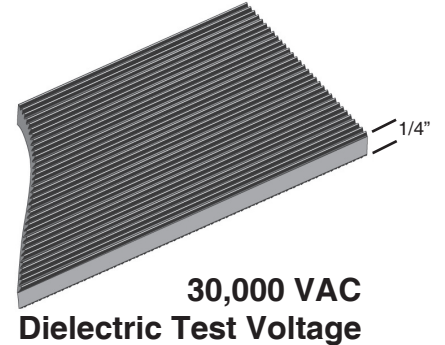
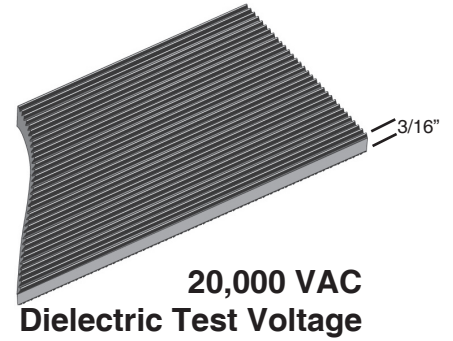

CORRUGATED SWITCHBOARD MATTING

- A specially compounded non-conductive corrugated matting designed to help prevent electric shock around high voltage electrical equipment, such as fuse boxes, and control panels.
- Now meets all optional requirements for Ozone Resistance, Flame Resistance, and Oil Resistance.
- Tested to ASTM D178/ANSI J6.7. Certification engraved on back.

CLASS 1 - 3/16" Thick Switchboard - Corrugated

- DIELECTRIC TEST VOLTAGE 20,000 VAC
- PROOF TESTED OVER ENTIRE SURFACE AT 10,000 VAC
- RECOMMENDED MAXIMUM USE VOLTAGE 7,500 VAC

Stock #	Size	Weight/Ln.Ft.
---------	------	---------------

Color: Black. Sold in full rolls only.

CLASS 2 - 1/4" Thick Switchboard - Corrugated & Diamond Pattern

- DIELECTRIC TEST VOLTAGE 30,000 VAC
- PROOF TESTED OVER ENTIRE SURFACE AT 20,000 VAC
- RECOMMENDED MAXIMUM USE VOLTAGE 17,000 VAC

Stock #	Size	Weight/Ln.Ft.
---------	------	---------------

SB424	2' x 75'	3.5 lbs.
SB436	3' x 75'	5.2 lbs.
SB448	4' x 75'	6.8 lbs.

Color: Black.

CLASS 3 - 3/8" Thick Switchboard - Corrugated

- DIELECTRIC TEST VOLTAGE 40,000 VAC
- PROOF TESTED OVER ENTIRE SURFACE AT 30,000 VAC
- RECOMMENDED MAXIMUM USE VOLTAGE 26,500 VAC

Stock #	Size	Weight/Ln.Ft.
---------	------	---------------

SB536	3' x 75'	7.7 lbs.
-------	----------	----------

Color: Black. Sold in full rolls only.

CLASS 4 - 1/2" Thick Switchboard - Corrugated

- DIELECTRIC TEST VOLTAGE 50,000 VAC
- PROOF TESTED OVER ENTIRE SURFACE AT 40,000 VAC
- RECOMMENDED MAXIMUM USE VOLTAGE 36,000 VAC

Stock #	Size	Weight/Ln.Ft.
---------	------	---------------

SB636	3' x 30'	10.7 lbs.
-------	----------	-----------

Color: Black. Sold in full rolls only.



MIL-SPEC SWITCHBOARD Mats

MIL-DTL-I5562 TYPE I (1/8") SMOOTH TOP

- Durable, marbleized, fire-retardant, electrically insulating surface is installed in naval vessels in high-voltage compartments.
- The Type I matting offers aesthetics and water-tight integrity with heat welded seams.

- Dielectric Test Voltage 30,000 VAC
- Proof Tested Over Entire Surface At 15,000 VAC
- Recommended Maximum Use Voltage 3,000 VAC



MIL SPEC TYPE I SMOOTH TOP SWITCHBOARD MATTING

Stock No.	Size	Weight/per roll
MILSPEC-I	36" x 75'	245.00 lbs
Standard Colors: Blue, Green, Beige, Gray.		
High Gloss: Blue, Green, Beige, Gray. Full rolls only. 1/8" Thick.		

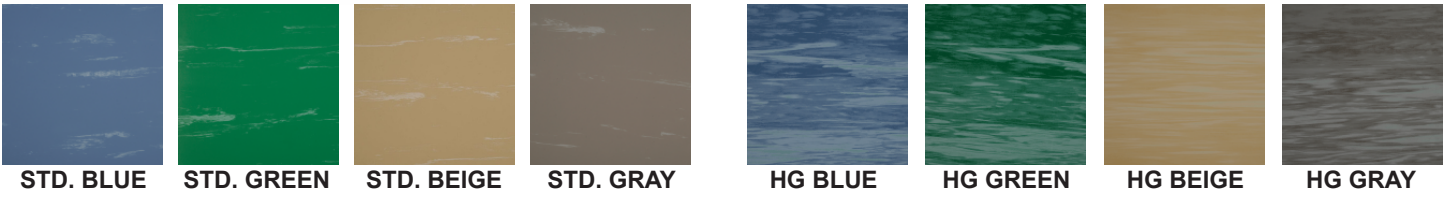
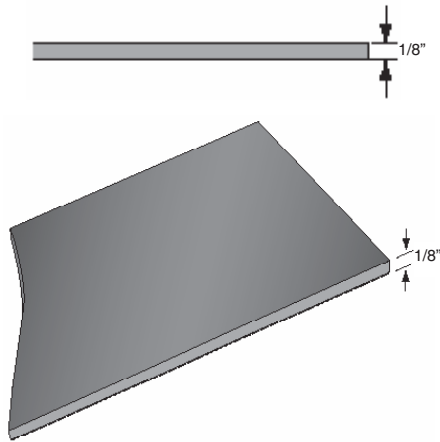

MIL-DTL-I5562 TYPE II (1/8") II SMOOTH TOP

- Type II smooth surface is fire-retardant, electrically insulating matting used as a portable runner in front of equipment and on workbenches.

- Dielectric Test Voltage 30,000 VAC
- Proof Tested Over Entire Surface At 15,000 VAC
- Recommended Maximum Use Voltage 3,000 VAC



MIL SPEC TYPE II SMOOTH TOP SWITCHBOARD MATTING

Stock No.	Size	Weight/per roll
MILSPEC-II	36" x 75'	245.00 lbs
Color: Black-cut lengths and full rolls, Blue, Green-full rolls only. 1/8" Thick.		

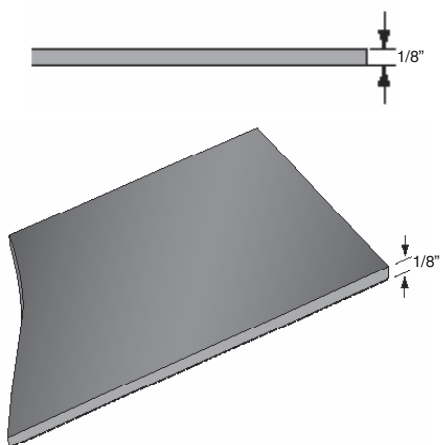

MIL -DTL-I5562 TYPE III (3/16") DIAMOND

- The Type III. diamond plate surface is slip-resistant, fire-retardant, electrically insulating matting and is installed as a portable runner in front of equipment and on workbenches.

- Type III runner is used by the Department of Defense and in many industrial and commercial applications.

- Dielectric Test Voltage 30,000 VAC
- Proof Tested Over Entire Surface At 15,000 VAC
- Recommended Maximum Use Voltage 3,000 VAC



MIL SPEC TYPE III DIAMOND SWITCHBOARD MATTING

Stock No.	Size	Weight/per roll
MILSPEC-III	36" x 75'	252.00 lbs.
Color: Gray-cut lengths and full rolls, Green-full rolls only. 3/16" Thick.		

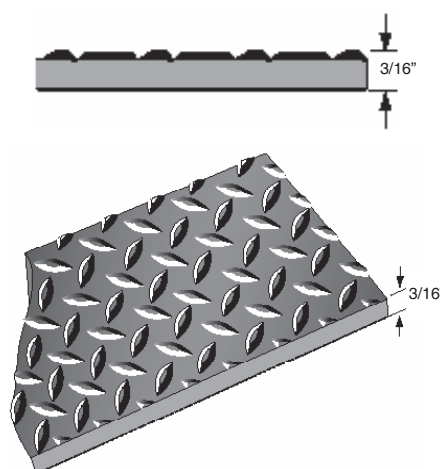



EASY KLEEN RIB RUNNER

- Vinyl Easy Kleen is a durable vinyl with a rounded, ribbed profile.
- Provides exceptional wear and is resistant to most acids and chemicals.
- Meets Flammability Test requirements of Motor Vehicle Safety Standard No. 302 (49 CFR 571.302). Stain and abrasion resistant.

SPIKE RESISTANT VINYL EASY KLEEN

- This spike-resistant matting is ideal for golf course and/or locker room use.
- 1/4" thick.

SPIKE PROOF VINYL EASY KLEEN

STOCK NO.	SIZES	WT./LN.FT.
EKS24	1/4" x 24" x 75'	3.33 lbs.
EKS36	1/4" x 36" x 75'	4.66 lbs.

Colors: Black, Brown, Green.
(24" Black only.) 1/4" Thick.

SPIKE RESISTANT
VINYL EASY KLEEN,
Vinyl Runner 1/4"

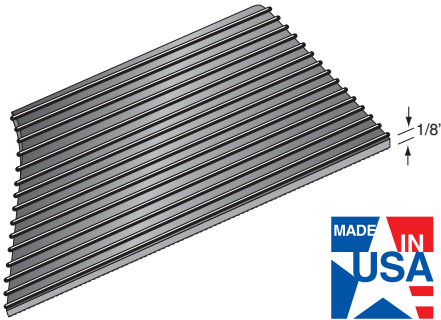
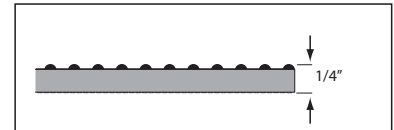

EASY KLEEN RIB RUNNER

Stock No.	Sizes	Wt./Ln.ft.
EK24	1/8" x 24" x 105'	1.50 lbs.
EK36	1/8" x 36" x 105'	2.20 lbs.
EK48	1/8" x 48" x 105'	2.60 lbs.
EK60(B)	1/8" x 60" x 105'	3.20 lbs.
EK36(W)	1/8" x 36" x 105'	2.20 lbs.

Colors: Black, Gray.
(60" Black only, White 36" only.) 1/8" Thick.

DIAMOND PLATE RUNNER

- This vinyl diamond plate is a uniquely engineered, deeply-embossed, "steel-deck" designed matting with embossed anti-skid backing.
- Diamond plate design offers exceptional wear in heavy traffic areas.
- Resists most oils, industrial chemicals, beverages and household chemicals.
- Diamond plate meets Flammability Test requirements of Motor Vehicle Safety Standard No. 302 (49 CFR 571.302).

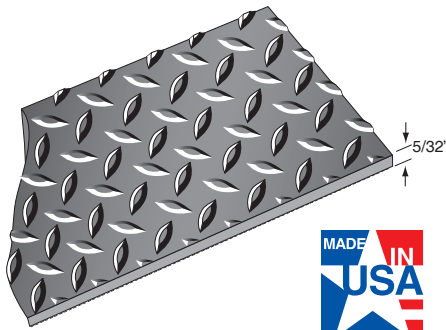

DIAMOND DECKPLATE RUNNER

Stock No.	Sizes	Wt./Ln.Ft.
DV36	5/32" x 36" x 75'	2.70 lbs.
DV48	5/32" x 48" x 75'	3.43 lbs.
DV60	5/32" x 60" x 75'	4.29 lbs.

Colors: Black, Gray. 60" Black only. 5/32" Thick.

DIAMOND DECKPLATE – SAFETY BORDER

Stock No.	Sizes	Wt./Ln.Ft.
DV24Y	5/32" x 24" x 75'	1.70 lbs.
DV36Y	5/32" x 36" x 75'	2.70 lbs.
DV48Y	5/32" x 48" x 75'	3.43 lbs.
DV60Y	5/32" x 60" x 75'	4.29 lbs.

Colors: Black/Yellow, Gray/Yellow. 60" Black/Yellow only. 5/32" Thick.

DIAMOND DECKPLATE – CHEVRON BORDER

DV24CV	5/32" x 24" x 75'	1.70 lbs.
DV36CV	5/32" x 36" x 75'	2.70 lbs.
DV48CV	5/32" x 48" x 75'	3.43 lbs.

Colors: Black/Yellow Chevron.

PYRAMID RUNNER

- This non-directional 3/16" pyramid pattern features an extremely slip-resistant surface, provides sure footing for safety and protects floors.
- Embossed backing for skid resistance.
- Resists most oils, greases, and fats.
- Meets Flammability Test requirements of Motor Vehicle Safety Standard No. 302 (49 CFR 571.302).

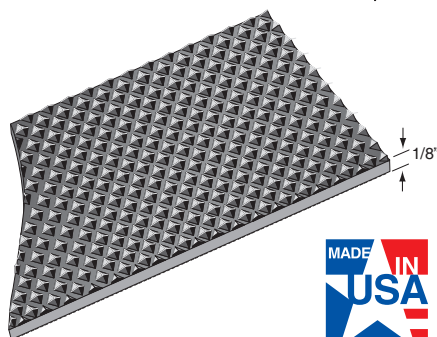

PYRAMID RUNNER

Stock No.	Sizes	Wt./Ln.Ft.
VP36	1/8" x 36" x 105'	2.60 lbs.
VP48	1/8" x 48" x 105'	3.50 lbs.

Colors: 36" Wide Black only.

Colors: 48" Wide Black, White. 1/8" Thick.



CORRUGATED RUNNER Matting

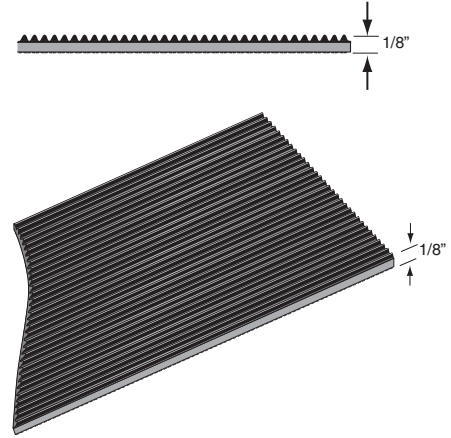

- **1/8" thick:** Medium duty corrugated, highly versatile, economical and easily cut to size.

CORRUGATED RUNNER

- Deep V-groove liner pattern, primarily for non-slip applications.
- Also provides floor protection for high traffic areas.
- Helps remove dirt and mud from shoes with only routine maintenance using a broom.

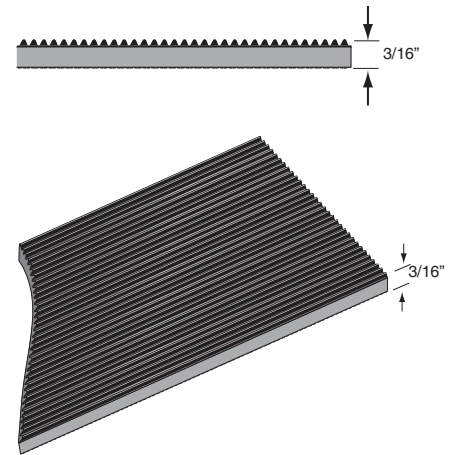

- **3/16" thick:** Heavy duty corrugated, the lightness and flexibility of regular corrugated, but will deliver longer life. Marine blue and orange colors available.

CORRUGATED RUNNER MATTING

Stock No.	Sizes	Wt./Ln. Ft.
1CV24	1/8" x 24" x 105'	1.50 lbs.
1CV36	1/8" x 36" x 105'	2.23 lbs.
1CV48	1/8" x 48" x 105'	2.86 lbs.
1CV72	1/8" x 72" x 105'	4.46 lbs.
Color: Black. 1/8" Thick.		
Stock No.	Sizes	Wt./Ln. Ft.
2CV36	3/16" x 36" x 75'	4.00 lbs.
2CV48 Black only	3/16" x 48" x 75'	5.33 lbs.
Color: Black, Marine Blue, Orange. 3/16" Thick.		
Stock No.	Sizes	Wt./Ln. Ft.
3CV24	1/4" x 24" x 75'	3.66 lbs.
3CV36	1/4" x 36" x 75'	5.33 lbs.
3CV48	1/4" x 48" x 75'	6.66 lbs.
Color: Black. 1/4" Thick.		

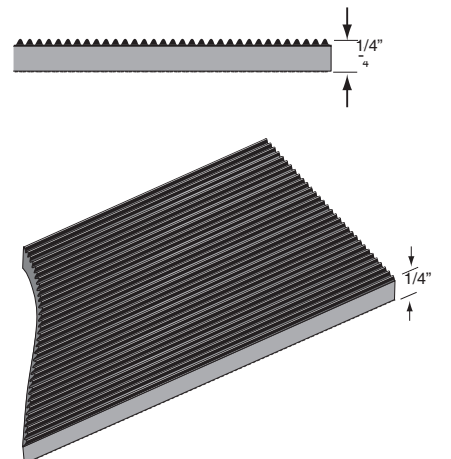

- **1/4" thick:** Super duty corrugated: this double-thickness matting provides dependable and long-lasting service in severe wear areas.

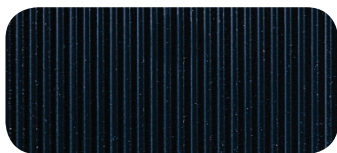

Black

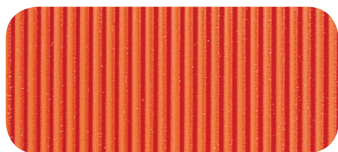

Orange (3/16" only)



Marine Blue (3/16" only)



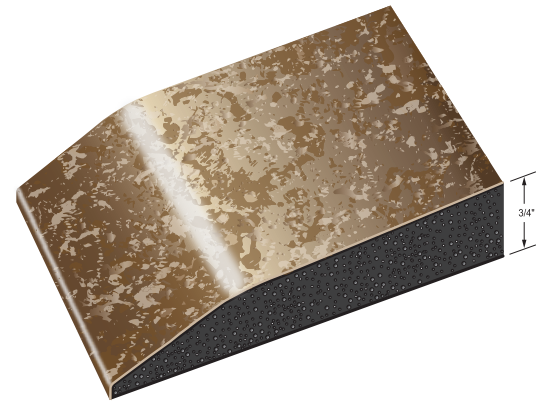

COMFORT CRAFT SONORA PREMIUM MATS

- The Comfort*Craft Sonora series gives you the tailored look and feel of polyurethane with a unique designer surface and four sizes & colors to choose from.
- Sonora adds color and flair to your business with intricate yet understated neutral tones, with a slight metallic finish. It is drop dead gorgeous and will definitely fit any décor
- Comfort Craft mats are designed to provide the simplest and most effective way to reduce standing fatigue and stress by providing optimal balance between compression and resistance, absorbing and dispersing shock while providing the necessary support for stability.
- Sonora has been developed with anti-bacterial and mildew resistance properties. A 5:1 ratio of water to bleach solution may be used as a disinfectant. Sonora meets State and Federal flammability requirements and contains no lead or other heavy metals. There are no VOCs or off gassing.
- Rhino Mats are known and respected worldwide for their superior performance and durability.
- The mission is simple – manufacture the world’s best anti-fatigue mat and facilitate the standing workers productivity through comfort.
- Comfort Craft Sonora is a full 3/4” thick.

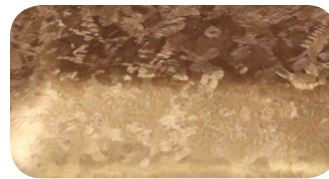

TOBACCO

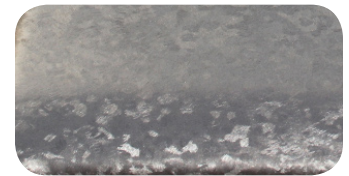

MINK



COAL



SAPPHIRE

COMFORT CRAFT SONORA 3/4” Premium Mats		
Stock No.	Size	Weight 3/4”
CCP2436	2’ x 3’	6.0 lbs. ea.
CCP2448	2’ x 4’	9.0 lbs. ea.
CCP2472	2’ x 6’	13.0 lbs. ea.
CCP3660	3’ x 5’	18.0 lbs. ea.
Colors: Tobacco, Mink, Coal, Sapphire		



COMFORT CRAFT PREMIUM MATS

- The Comfort*Craft Premium series gives you the tailored look and feel of polyurethane with a unique designer surface.
- Add a splash of color and pinache to your kitchen with these distinct looks and colors.
- Comfort Craft mats are designed to stimulate circulation in feet, legs and lower back by providing the simplest and most effective way to reduce standing fatigue and stress.
- Circulation is stimulated by the carefully engineered polyurethane sponge formulation that provides optimal balance between compression and resistance which absorbs and disperses shock while providing the necessary support for stability.
- Rhino Mats are known and respected world wide for their superior performance and durability.
- The mission is simple – manufacture the world’s best anti-fatigue mat.
- Comfort Craft Premium is a full 3/4” thick.



COMFORT CRAFT PREMIUM Mats		
Stock No.	Size	Weight 3/4"
CCP2436	2' x 3'	6.0 lbs ea.
CCP2448	2' x 4'	8.0 lbs ea.
CCP2472	2' x 6'	12.0 lbs. ea.
CCP4848	4' x 4'	33.0 lbs. ea.
CCP3660	3' x 5'	21.0 lbs. ea.

Colors & Styles: See next page.
Specify color and style when ordering.



Catmandoo



Mocha



Ochre



Saddle

Crocodile

Triathalon



Topaz



Matte Black



Taupe



Water



Cardinal



Copper



Deep Plum



Ebony



Lagoon



Lion



Pine



Saddle



DOCTOR STAND-EZE™ Anti Fatigue Mats

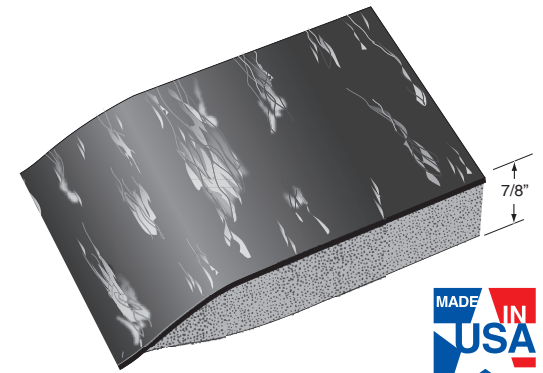
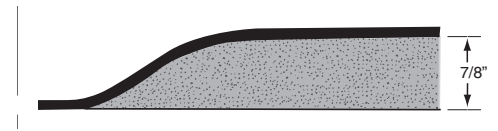
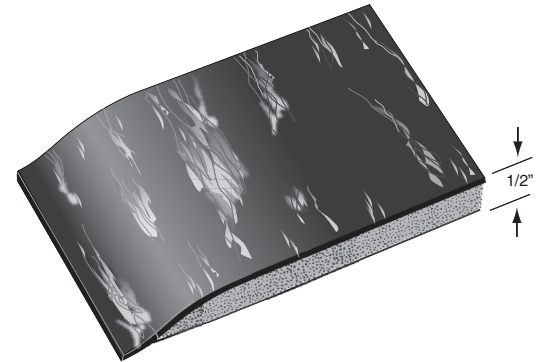
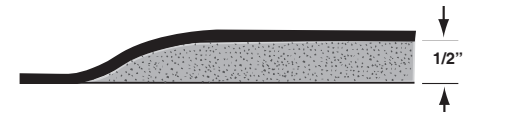

DOCTOR STAND-EZE™

- An Anti-Fatigue Mat with attractive smooth marbled surface and non-porous encapsulated construction that cleans up easily with most disinfecting agents, meeting the challenge of laboratory and medical environments.
- Doctor Stand-Eze is ergonomically designed to stimulate blood flow and prevent fatigue. It displays excellent physical properties such as tensile strength, tear resistance and cleanability.
- Doctor Stand-Eze Anti-Fatigue mats are available in two styles. The single sponge style is 1/2" thick and the double sponge is a full 7/8" thick, double the thickness of ordinary mats. The base is sealed in a non-porous envelope that is permanently bonded to the backside.
- Three year unconditional, non-prorated warranty insures against cracking or fracturing.



Blue



Solid Black



Brown

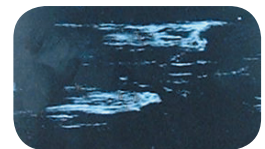

Black/White

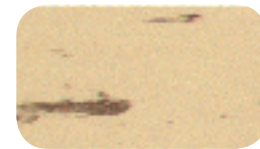

Tan

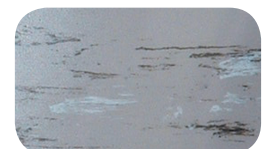

Gray



Charcoal



Sandalwood

DOCTOR STAND-EZE ANTI-FATIGUE

For 7/8" mats add "DS" to stock number

Stock No.	Size	Weight Ea. 1/2"	Weight Ea. 7/8"
DSE-2436	2' x 3'	9.0 lbs.	12.0 lbs.
DSE-3648	3' x 4'	18.0 lbs.	24.0 lbs.
DSE-3660	3' x 5'	22.0 lbs.	30.0 lbs.

CUSTOM SIZES-available in lengths up to 20 lin. Ft.

Stock No.	Width	Wt./Lin.Ft. 1/2"	Wt./Lin.Ft.7/8"
DSE-36	36"	4.2 lbs.	4.8 lbs.

Colors: Blue, Brown, Tan, Charcoal, Grey, Sandalwood, Black/White, Solid Black.



Rx ANTI-FATIGUE MATS

- Rx Anti-Fatigue mats are designed to reduce the fatigue that nurses, doctors and surgeons experience from long hours of standing. Optimizing the medical professionals ability to focus on critical task in areas such as operating rooms, lab research and pharmacies is of the utmost priority.
- Closed cell polyurethane foam provides the optimum balance between compression, deflection and stability. The antimicrobial top surface is easy to clean and specifically designed to stand up to hospital-grade disinfectants and quaternary cleaners. It is also 7P free and contains no phthalates.
- Top surface design took into consideration the usage of damp or dry surgical booties and fluid spills that lower the coefficient of friction. Rx surpassed both OSHA recommended, static COF & kinetic COF, threshold for friction.
- Rx Anti-Fatigue is 3/4" thick, available in 2'X3', 2'X6' and 3'X5' and three colors, Crystal (beige), Tourmaline (blue) & Nickel (gray).

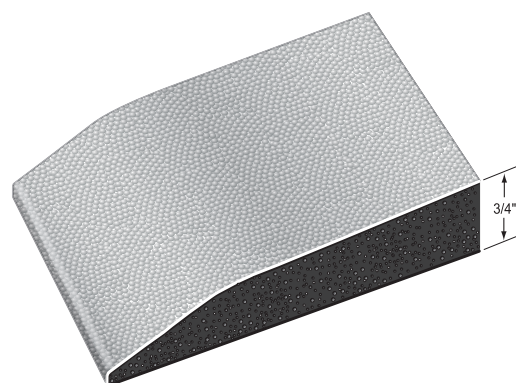

Tourmaline

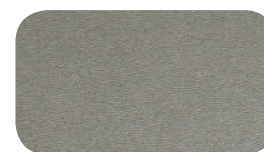

Nickel

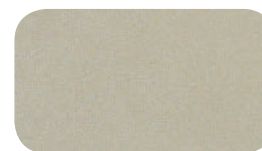

Crystal

Rx ANTI-FATIGUE MATS		
Stock No.	Sizes	Weight
CCP-RX-23	2' x 3'	15.0 lbs.
CCP-RX-35	3' x 5'	22.0 lbs.
CCP-RX-26	2' x 6'	30.0 lbs.
Colors: Crystal (beige), Tourmaline (blue), and Nickel (gray).		
Thickness 3/4"		



Rx (BED-SIDE) FALL MAT

- Rx Fall Mats are identical in every way to our Rx Anti-Fatigue, excepting a lower density foam backing. The Rx Fall Mat protects against bedside fall injury and is an effective fall management tool used in nursing homes, hospitals and private homes worldwide.
- The Rx Fall mat is a middle of the road product, offering a balance between impact absorption and stability for standing.
- Rx Fall Mat has an approximate impact force reduction of 80%, and a reduced standing stability of approximately 20% when compared to flat hard surface.
- Closed cell polyurethane foam with an antimicrobial top surface that is easy to clean and specifically designed to withstand hospital-grade quaternary cleaners and disinfectants.
- Top surface design took into consideration, the wearing of socks and fluid spills that lower the coefficient of friction. Rx surpassed both OSHA recommended, static COF & kinetic COF threshold for friction.
- Beveled edges minimize trip hazard and allows wheelchairs and medical equipment to be rolled over mat. Rx Fall Mat is 3/4" thick, available in 2'X6' and 3'X5' sizes and three colors, Crystal (beige), Tourmaline (blue) & Nickel (gray).

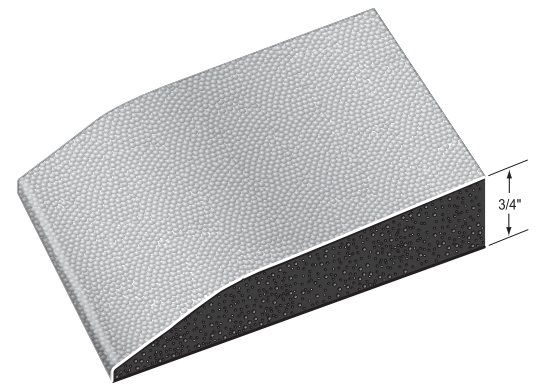

Tourmaline

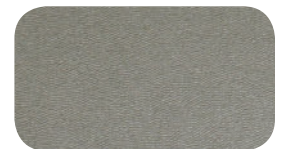

Nickel

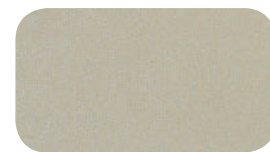

Crystal

COMFORT CRAFT Rx FALL Mats

Stock No.	Size	Weight 3/4"
CCP3660-RX	3' x 5'	21.0 lbs. ea.
CCP2472-RX	2' x 6'	12.0 lbs. ea.

Colors: Crystal, Tourmaline, and Nickel.



RHINO SIMPLE SOLUTION

Simple Solution facilitates a neat and tidy decontamination of all footwear, including light feminine sandals and should be used in intramural settings where general public traffic is expected.

Rhino “Simple Solution” carpet mats are not your ordinary mat – do not confuse our advance engineered product with a traditional mat. Here are a few of our differentiating characteristics:

- Simple Solution has a ½” water dam design for containment and a raised reinforced pattern creating a bi-level surface.
- A balanced wicking of disinfectant is provided by our use of a broad fibered polypropylene.
- Using your existing disinfectant diluted per product specifications, Fill the trayed 2’X3’ mat with approximately three cups of fluid to even or slightly below the top of the ribbed pattern.
- Recharging or refilling your solution filled 2’X3’ mat will vary due to the temperature, humidity and traffic volume.
- Simple Solution is also offered with an optional 2 ea set of 3’X3’ drying mats, sold together or sold separately.
- The simplest most effective shoe disinfectant method is the multi-purpose system from Rhino, “Simple Solution”.
- Recommended for hotels, restaurants, hospitals, office buildings, doctor and dental offices, high traffic commercial retail areas
- Protect employees and customers. A great customer experience begins with a clean and anesthetic floor.

RHINO SIMPLE SOLUTION		
Stock No.	Size	App. Weight.
RXSS-2335-2	1 ea 2’x3’ Tray & 2 ea 3’x3’	42.0 lbs.
RXSS-2436	1 ea 2’x3’ Tray’	8.0 lbs.
Color: Charcoal.		
3/8” Thick.		



Charcoal

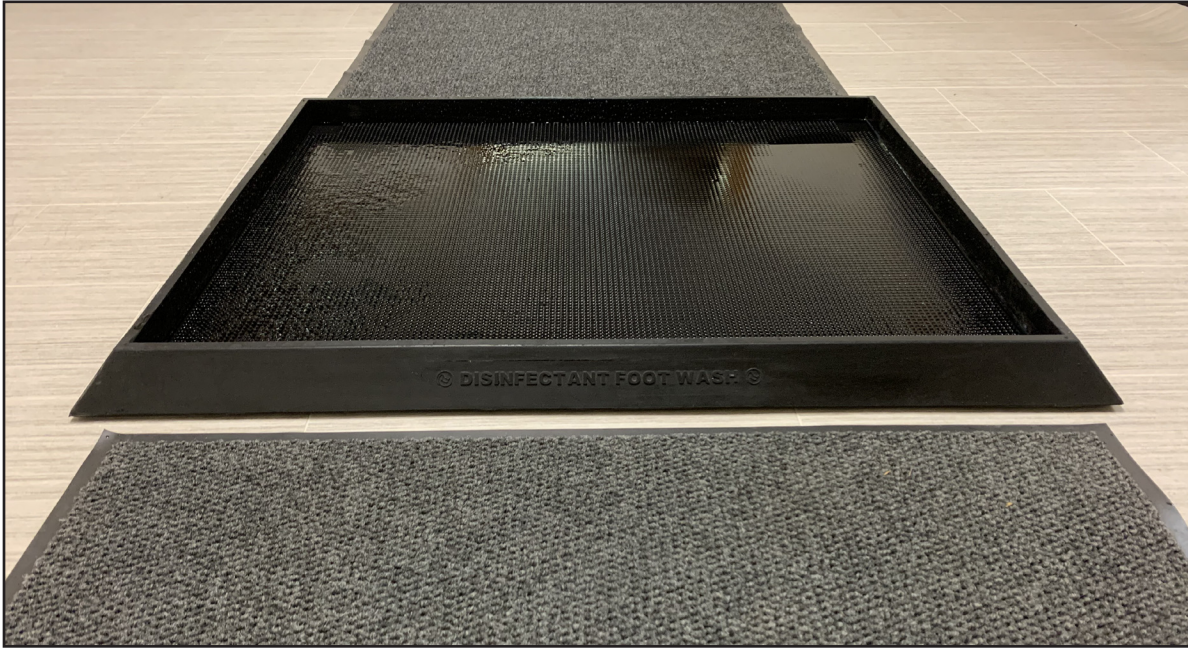

RHINO SHOE WASH

The Rhino Shoe Wash Mat Station sets a new industry benchmark offering a practical, utilitarian and budget priced solution for the robust protection of people and interior environments. The system is ideally suited for commercial and industrial applications including food processing, laboratories, hospitals, catering, medical and hospitality environments.

- The Rhino Decontamination Station features a 2" high water dam design for collection, containment and disinfection of all tracked in foreign materials. This same station does the removal work with 30,000 molded scraper fingertips that are each 0.3" high, offering an automatic scrubbing action that dislodges contaminants from shoes and boots.
- The decontamination station is a compact 32" x 38", yet is sized for a two-step area for best in class results for cleaning and sanitizing. With a non-slip design on the underside of the mat and weighing in at a solid 22 pounds, the Rhino Decontamination Station will not slip.
- Using your existing disinfectant diluted per product specifications, fill the station with a gallon of fluid, just covering the tops of the fingertips. Replenishing your disinfectant in the station is as easy as 1, 2, 3 and can be done as your needs dictate.
- The product is chemically resistant to nearly all disinfectant solutions as it is made from a highly engineered formulation designed specifically for this purpose. The Rhino Disinfectant Station product also demonstrates excellent low temperature flexural properties and is offered with a 5 year warranty.
- The Rhino Decontamination Station is also offered with an optional 2 each set of 3' x 3' drying mats, sold together as one unit or sold separately.

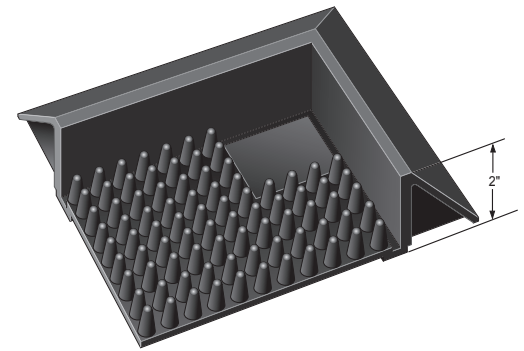
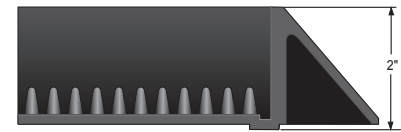

RHINO SHOE WASH

Stock No.	Size	App. Weight.
RSW-3238-2	1 ea 32" x 38" Tray & 2 ea 3'x3'	42.0 lbs.
RSW-3238	1 ea 32" x 38" Tray'	22.0 lbs.

Color: Black, Drying Mat Charcoal.
3/8" Thick.

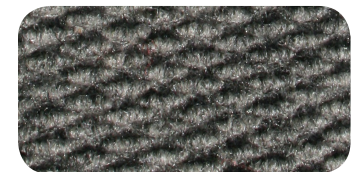

Charcoal Drying Mat



FINGER TIP

- Finger Tip mats from Rhino are the perfect all-weather mat. Hundreds of flexible and durable rubber bristles are molded into the surface of the mat, that perform a scrubbing action, as they brush off mud, slush, snow, driveway and parking lot grime, dirt and oil.
- The no-trip beveled edges around the parameter of Fingertip Mats creates a dam effect, holding pounds of debris between cleanings. Cleaning is simple and easy, turn over, shake out or hose off.
- Rhino Finger-Tip mats are manufactured from natural tree rubber, harvested from the Para rubber tree. Natural rubber is nature's contribution to the elastomer field and offers the advantage of high resilience, high tensile and tear properties and good flexing qualities at low temperatures.
- Rhino Finger-Tip mats are 5/8" thick, Color: Black and offered in four different sizes.

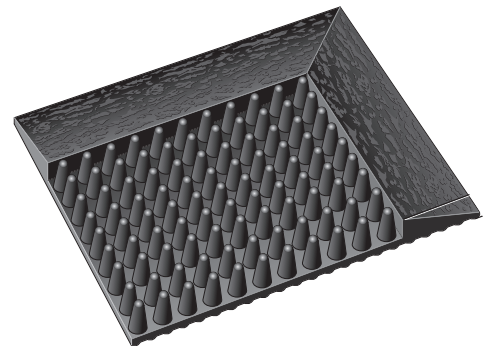

FINGER-TIP MATS		
Stock No.	Size	App. Weight.
FT2432	24" x 32"	7.0 lbs.
FT3239	32" x 39"	13.0 lbs.
FT3660	36" x 60"	25.0 lbs.
FT3672	36" x 72"	30.0 lbs.
Color: Black only.		
5/8" Thick.		



TRITAN® ULTRA SCRAPE® Multi-Purpose Mats

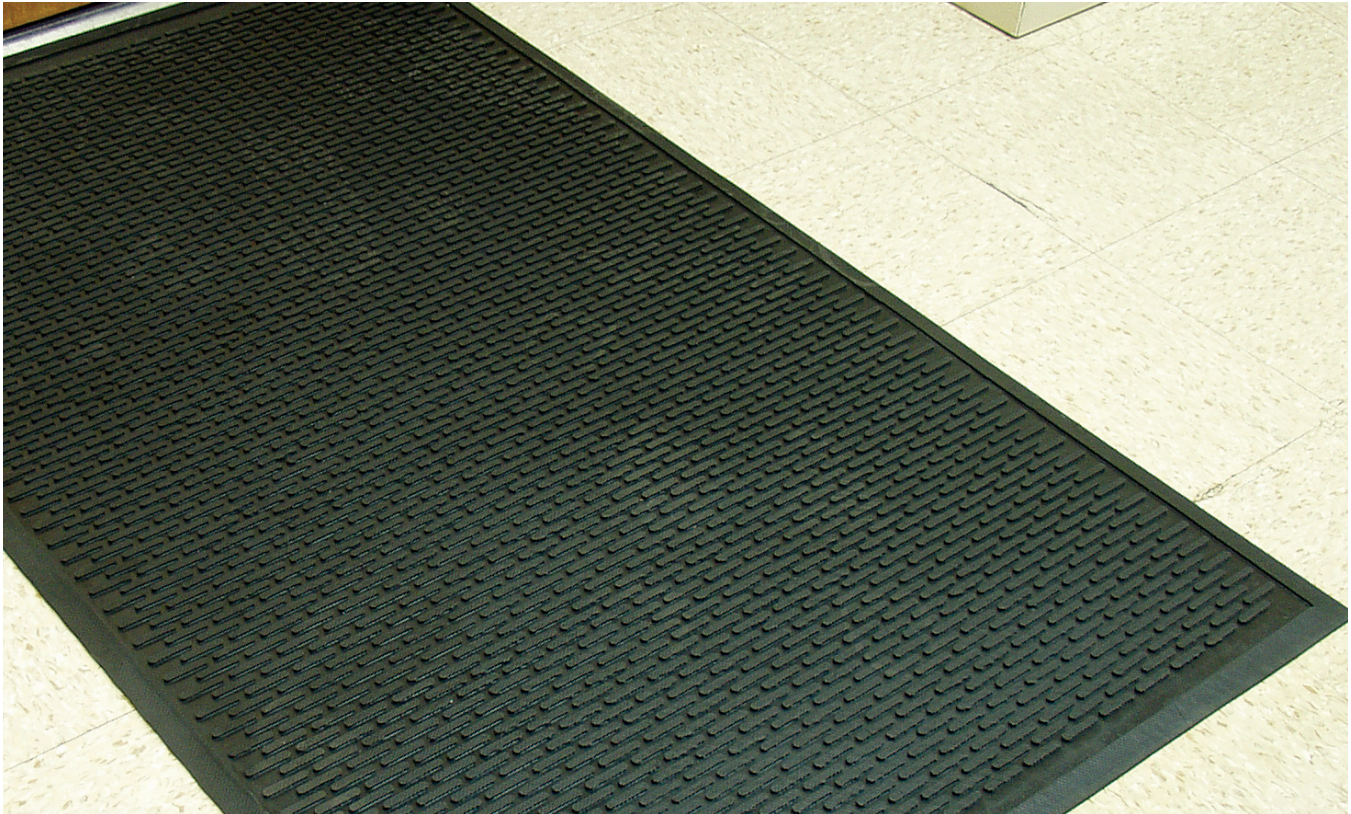

TRITAN® ULTRA SCRAPE

- Tritan Ultra Scrape mats provide the optimum defense at entrances against dirt, pebbles, and grit being tracked into your facility.
- Ultra Scrape mats work wonders towards preventing slip and fall accidents in environments where traction is essential, outside entrances, locker rooms, lunch counters, and work stations.
- Low profile, easy to clean - just shake or hose off and not affected by most greases and oils.
- The Tritan series of mats from Rhino are manufactured from recycle trim rubber from the tire manufacturing plants of Pirelli® and Michelin®. Both iconic brands renowned for formulating the best rubber compounds in the world. Our utilization of these materials enables us to offer a five-year guarantee on the Tritan Ultra-Scrape product.

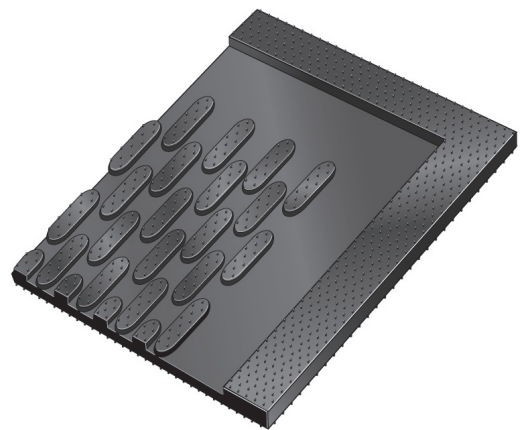
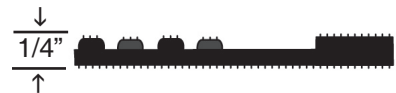

TRITAN ULTRA SCRAPE

Stock No.	Size	App. Weight.
US3660	3' x 5'	18.5 lbs.
US4872	4' x 6'	29.0 lbs.
US3696	3' x 8'	29.0 lbs.
US310	3' x 10'	37.0 lbs.

Colors: Black only.
1/4" Thick



TOWN 'N' COUNTRY Entrance Mats



TOWN 'N' COUNTRY

- Town & Country traditional square nub design surface removes and stores dirt and moisture between cleanings.
- Strong highly stain resistant solution dyed polypropylene fabric.
- Rubber reinforced surface pattern prevents crushing and extends performance life of mat.
- Water Dam design helps trap soil and moisture while reducing trip hazard with cleated back for increased traction.
- Recommended for hotels, restaurants, hospitals, office buildings and high traffic commercial areas.
- Easily cleaned by vacuum, hose down or pressure washed, “not launderable”.

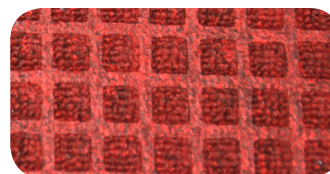
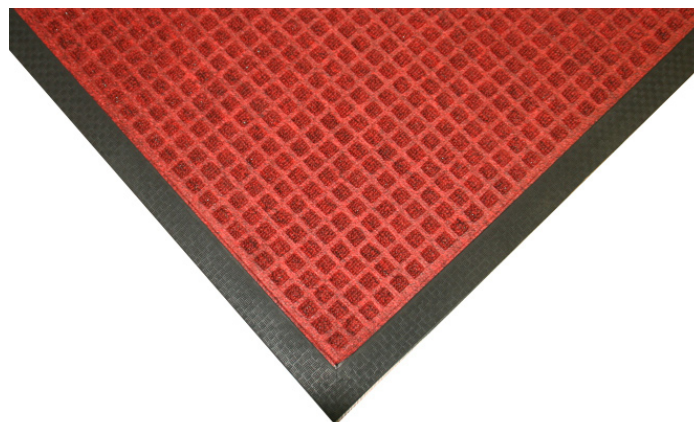

Red/Black

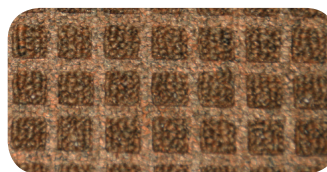

Brown

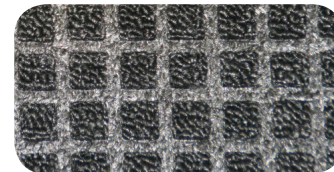

Charcoal

TOWN 'N' COUNTRY (STOCK SIZES)

Stock No.	Sizes	App. Weight.
TNC-2436	2' x 3'	7.0 lbs.
TNC-3660	3' x 5'	17.0 lbs.
TNC-4872	4' x 6'	27.0 lbs.

Colors: Brown, Charcoal, Blue, Red/Black.

OPUS Entrance Mats



OPUS

- Opus high fashion diamond design surface removes and stores dirt and moisture beneath shoe level.
- Strong highly stain resistant solution dyed polypropylene fabric.
- Rubber reinforced surface pattern prevents crushing and extends performance life of mat.
- Water Dam design helps trap soil and moisture while reducing trip hazard with cleated back for increased traction.
- Recommended for hotels, restaurants, hospitals, office buildings and high traffic commercial areas.
- Easily cleaned by vacuum, hose down or pressure washed, “not launderable”.

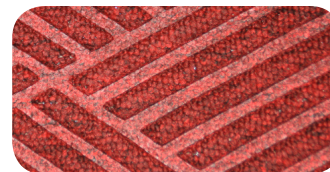

Red/Black

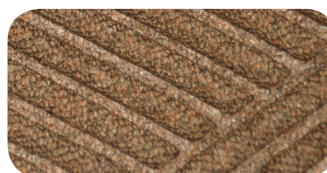

Brown



Charcoal

OPUS (STOCK SIZES)

Stock No.	Sizes	App. Weight.
OPUS-2436	2' x 3'	7.0 lbs.
OPUS-3660	3' x 5'	17.0 lbs.
OPUS-4872	4' x 6'	27.0 lbs.

Colors: Brown, Charcoal, Blue, Red/Black.



CROSSHATCH Entrance Mats

CROSSHATCH

- Crosshatch high fashion parquet design surface removes and stores dirt and moisture beneath shoe level.
- Strong highly stain resistant solution dyed polypropylene fabric.
- Rubber reinforced surface pattern prevents crushing and extends performance life of mat.
- Water Dam design helps trap soil and moisture while reducing trip hazard with cleated back for increased traction.
- Recommended for hotels, restaurants, hospitals, office buildings and high traffic commercial areas.
- Easily cleaned by vacuum, hose down or pressure washed, "not launderable".



Red/Black

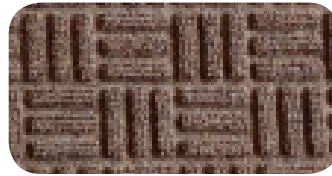

Brown



Charcoal

OPUS (STOCK SIZES)

Stock No.	Sizes	App. Weight.
CROSS-2436	2' x 3'	7.0 lbs.
CROSS-3660	3' x 5'	17.0 lbs.
CROSS-4872	4' x 6'	27.0 lbs.

Colors: Brown, Charcoal, Blue, Red/Black.



POLYOLEFIN Carpet Mats

POLY-OLEFIN

- A decorative, all purpose mat at a budget price.
- Carpet surface made of durable 100% continuous filament olefin...bonded to stain-resistant, slip-resistant base.
- Dirt hiding tweed pattern is universally popular.



Charcoal



Red/Black



Walnut



Solid Black

POLY-OLEFIN MATS (Stock sizes)

Stock No.	Size	App. Wt.
PPV-2436	2' x 3'	4.2 lbs.
PPV-3660	3' x 5'	10.5 lbs.
PPV-4872	4' x 6'	16.8 lbs.

Custom Sizes - available in lengths up to 60 lin. ft.

Stock No.	Size	App. Wt.
PPV-36	3' x 60'	2.0 lbs. lin. ft.
PPV-48	4' x 60'	2.7 lbs. lin. ft.
PPV-72	6' x 60'	4.0 lbs. lin. ft.

Colors: Beige, Blue, Red/Black, Charcoal, Walnut, Solid Navy, Hunter Green, Solid Gray, Solid Black

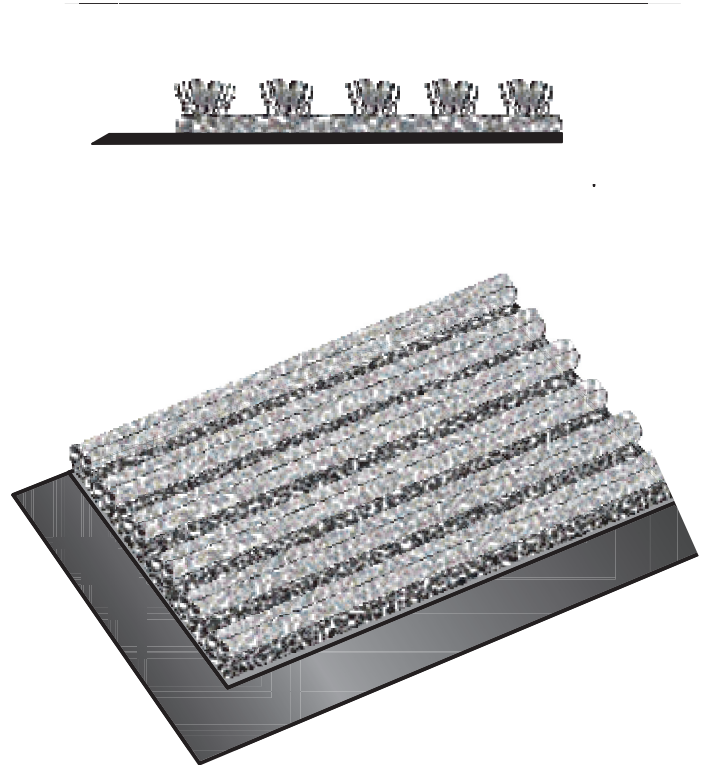

BRUSH-RIB

- The high fashion look of fine carpeting in a hi-lo rib pattern with outstanding durability in the toughest indoor or outdoor installations.
- Scrapes dirt and grit off shoes and removes moisture at the same time.
- 100% polypropylene face carpeting on heavy-duty slip-resistant and stain-resistant vinyl base.
- Brush-Rib mats feature six colors.



Pepper

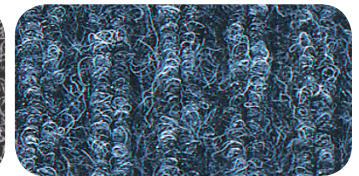

Blue

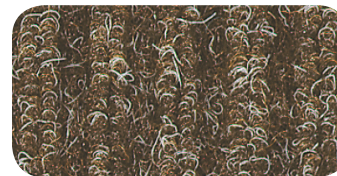

Brown

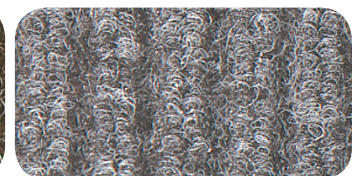

Solid Gray



Red

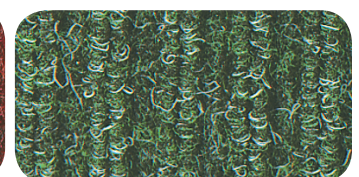

Green

BRUSH-RIB MATS (Stock Sizes)

Stock No.	Size	App. Wt.
BRV-2436	2' x 3'	4.8 lbs.
BRV-3660	3' x 5'	12.0 lbs.
BRV-4872	4' x 6'	19.2 lbs.

Custom Sizes – available in lengths up to 60 lin. ft.

Stock No.	Size	App. Wt.
BRV-36	3' x 60'	2.3 lbs. lin. ft.
BRV-48	4' x 60'	3.1 lbs. lin. ft.
BRV-72	6' x 60'	4.6 lbs. lin. ft.

Colors: Pepper, Blue, Brown, Solid Gray, Red, Green.





RHINO DIAMOND STAIR TREADS



RHINO DIAMOND STAIR TREADS

- Rhino Diamond stair treads are a practical, utilitarian product for preventing stair related falls.
- For use in Industrial / commercial buildings / residential steps cellars and decks.
- Stair related falls are the second leading cause of accidental injuries, causing more than one million injuries and 12,000 deaths per year, with 60% being residential.
- Rhino Diamond Stair Treads are manufactured with a combination of natural and recycled rubber and are easily cut to size using a utility knife and straight edge.
- Securing with double sided carpet tape offers reliable stability. It also can be removed easily without causing damage to sub-surfaces. If a permanent installation is not wanted, treads can be simply placed on the steps. In many cases the natural traction provided by the rubber is enough to keep the treads in-place. Permanent installation requires a clean substrate, using 2 part epoxy flooring adhesive, applied to both stairs and treads.
- Diamond Treads are 10"X29-3/8"x3/16" thick with a 1" square nose
- Weight: 1.8 lbs each; Color: Black. Simply sweep with a broom using a mild household detergent solution.
- Sold 6 per package.

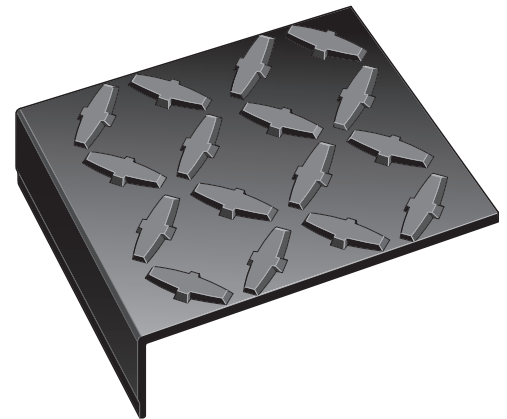
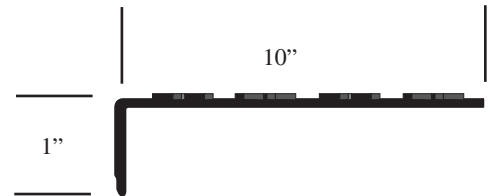

RHINO DIAMOND STAIR TREADS		
Stock No.	Size	Weight Ea.
SC-2448	10"X29-3/8"X3/16"	1.8 lbs
Sold in 6 packs		11 lbs
Color: Black only.		

LIST PRICE
\$62.50
6 PER PACKAGE



RHINO BAR STAIR TREADS

- Rhino Bar stair treads are a practical, utilitarian product for preventing stair related falls.
- For use in Industrial / commercial buildings / residential steps cellars and decks.
- Stair related falls are the second leading cause of accidental injuries, causing more than one million injuries and 12,000 deaths per year, with 60% being residential.
- Rhino Bar Stair Treads are manufactured with a combination of natural and recycled rubber and are easily cut to size using a utility knife and straight edge.
- Securing with double sided carpet tape offers reliable stability. It also can be removed easily without causing damage to sub-surfaces. If a permanent installation is not wanted, treads can be simply placed on the steps. In many cases the natural traction provided by the rubber is enough to keep the treads in-place. Permanent installation requires a clean substrate, using 2 part epoxy flooring adhesive, applied to both stairs and treads.
- Bar Treads are 10"X29-1/2"x7/32" thick with a 1" square nose
- Weight: 2.2 lbs each; Color: Black. Simply sweep with a broom using a mild household detergent solution.
- Sold 6 per package.

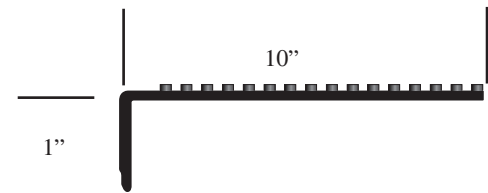

RHINO BAR STAIR TREADS		
Stock No.	Size	Weight Ea.
SC-2448	10"X29-1/2"X7/32"	2.2 lbs
Sold in 6 packs		14 lbs
Color: Black only.		

LIST PRICE
\$62.50
6 PER PACKAGE



TRITAN® BUMPERS AND WHEEL CHOCKS



- Tritan Bumpers and Wheel Chocks are manufactured from a tough durable “almost indestructible” combination of recycled tire rubber compounds, reinforced with nylon and polyester fabric. This combination of ingredients provide our bumpers and chocks with excellent properties for long lasting use and are designed to maximize safety in loading dock and material handling areas.
- Tritan bumpers and chocks suffer no deterioration from ozone exposure and weathering, no signs of deterioration at 400 degrees, Fahrenheit. No fracture or visible cracks due to cold temperature, -45 degrees, Fahrenheit. Tritan’s high fabric content creates a product that is tear, cut and abrasion resistant while maintaining it’s elasticity and impact absorption properties.
- Tritan bumpers eliminate dock damage, costly repairs and provide the needed protection for approaching vehicles.
- Tritan heavy duty wheel chocks provide maximum gripping power, totally immobilizing trailers, trucks to prevent wheel slippage accidents while vehicles are being loaded, unloaded.
- In addition to the industry standard items shown on this catalog, we can manufacture any similar molded product per customer specification.

PROPERTY	ASTM	RESULT
TENSIL STRENGTH (PSI)		
WITH GRAIN, MIN	D412	992.9
ACROSS GRAIN, MIN	DIE C	737.4
ELONGATION (%)		
WITH GRAIN, MIN	D412	46.6%
ACROSS GRAIN, MIN	DIE C	83.3%
HARDNESS, SHORE A	D2240	73-84
TEAR RESISTANCE (LBF/PULG)		
WITH GRAIN, MIN	D624	251.73
ACROSS GRAIN, MIN	DIE B	370.31
COMPRESSION RESISTANCE (PSI)	D695-96	756.24
HEAT AGING	D573	-0.4%
CHANGE IN:	70 HRS	-5.9%
	@ 70 C	. +3
SPECIFIC GRAVITY		1.15 - 1.19
BRITTLENESS	ASTD2137	NO CRACKS
@-40C	-94 (00)	NO CRACKS
OZONE AGING RESISTANCE	D 624-00	219.5
50 HRS @ 80 PPHM		-13%
FLAMABILITY	FMVSS 302	24
FLAMABILITY OF INTERIORS REQUIREMENTS		PASS
ABRASION NBS (INDEX)	D1630	258.9

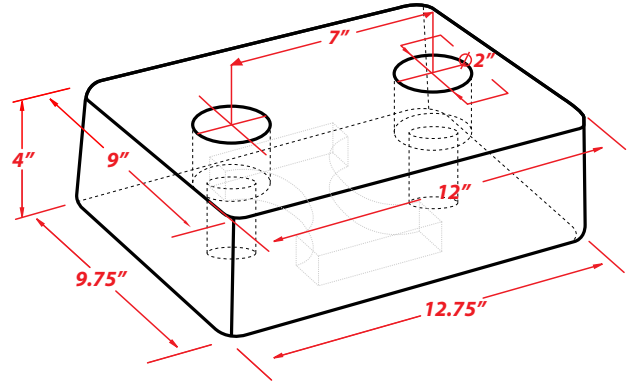
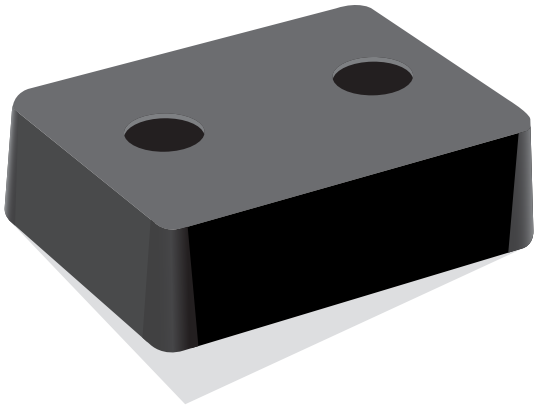

Stock No.	Size	Weight Ea.
BGPF	4x9.75x12.75	18.7 lbs.

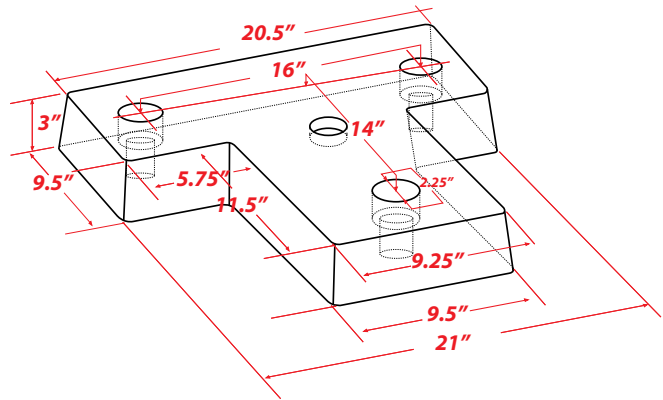
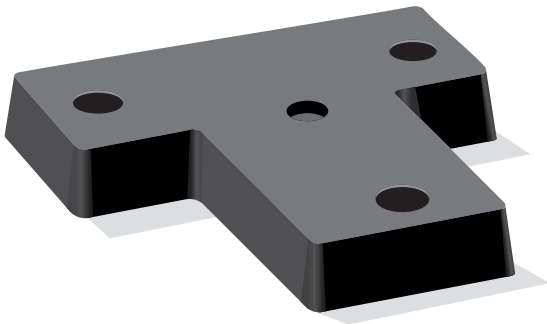

Stock No.	Size	Weight Ea.
RFTF	3x21x20.5	33.0 lbs.

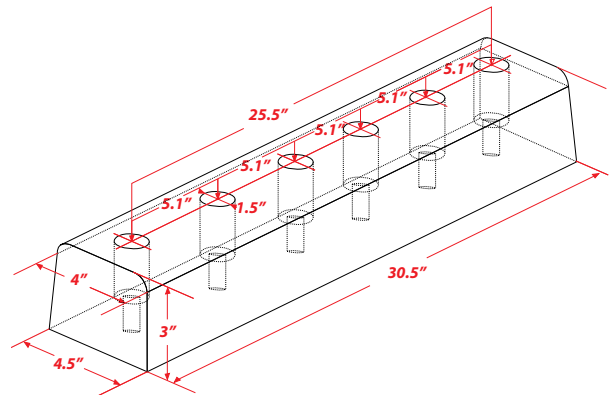
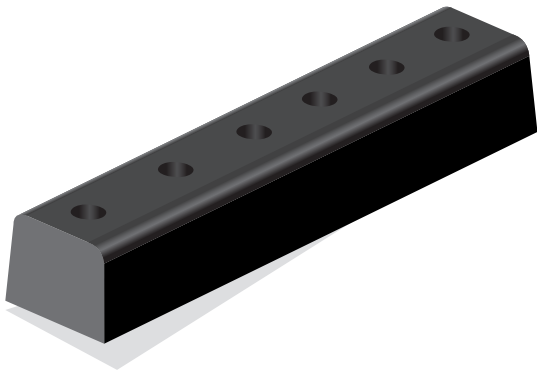

Stock No.	Size	Weight Ea.
DB3M	3x30.5x4.5	15.6 lbs.



TRITAN® DOCK PROTECTORS

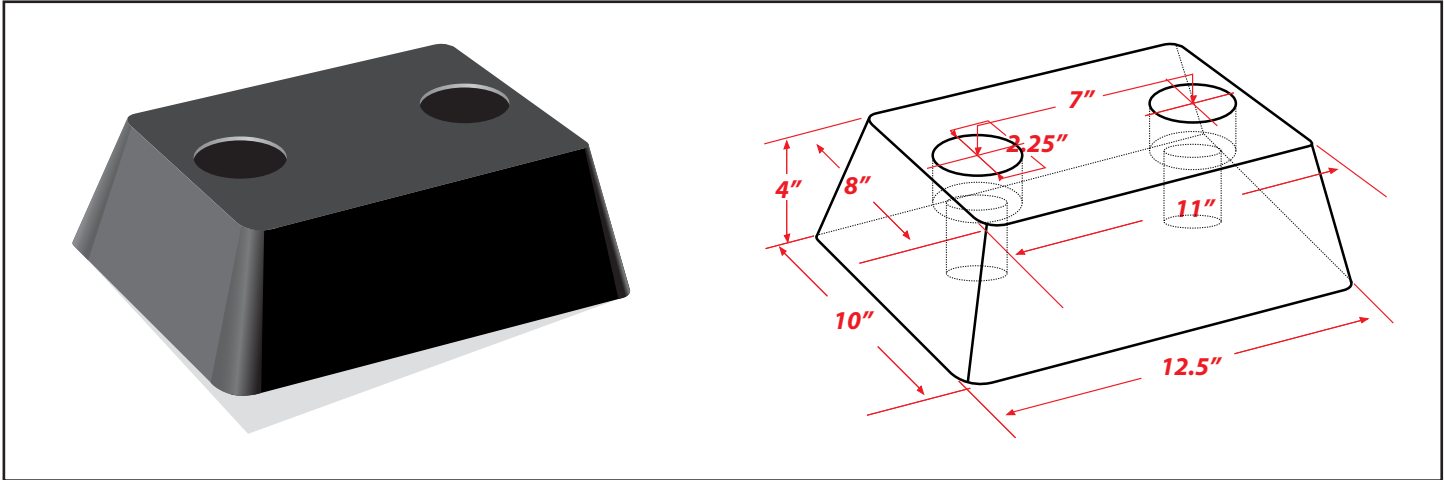

Stock No.	Size	Weight Ea.
NPLF	4x10x12.5	13.4 lbs.

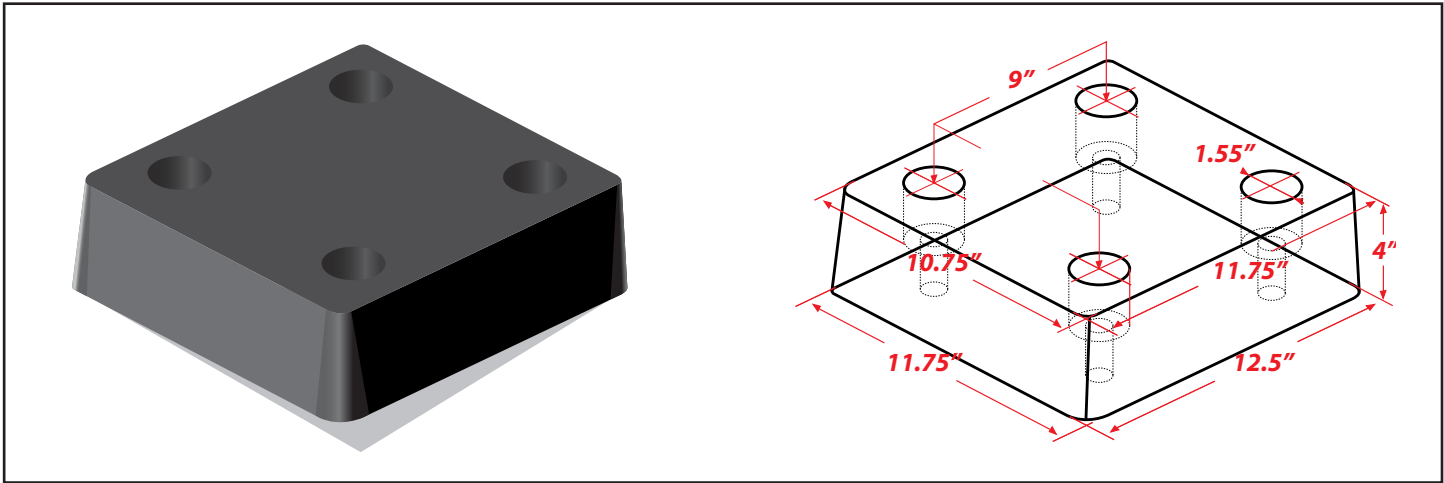

Stock No.	Size	Weight Ea.
NR4F	4x11.75x12.5	20.6 lbs.

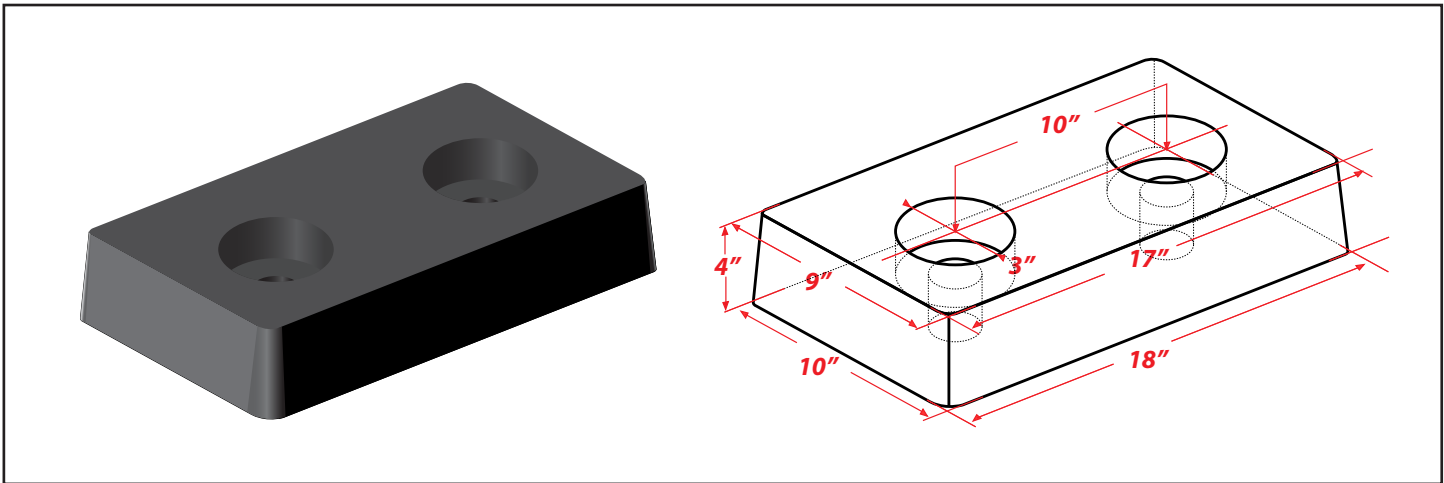

Stock No.	Size	Weight Ea.
PL4F	4x10x18	26.5 lbs.

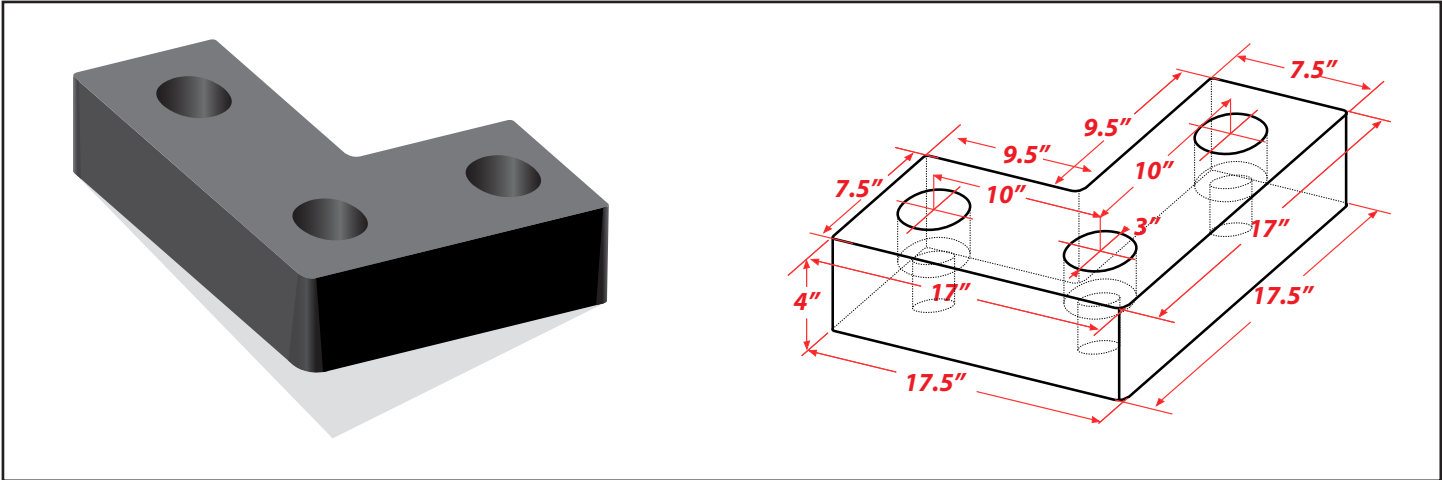

Stock No.	Size	Weight Ea.
RLFF	4x17.5x17.5	34.0 lbs.

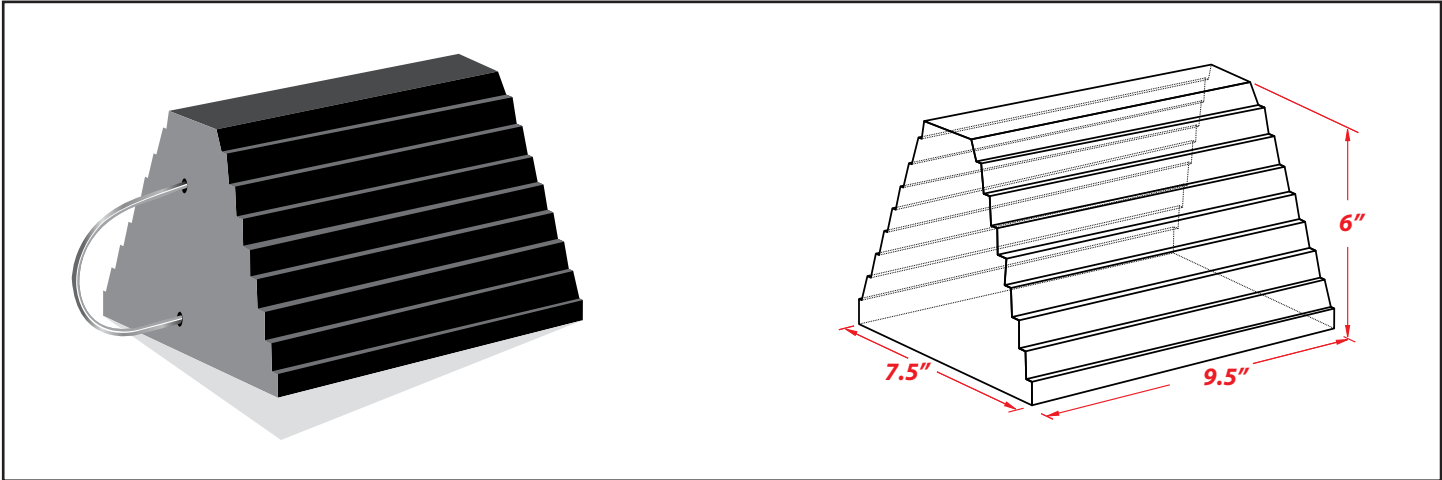

Stock No.	Size	Weight Ea.
CHUF	6x9.5x7.75	9.5 lbs.

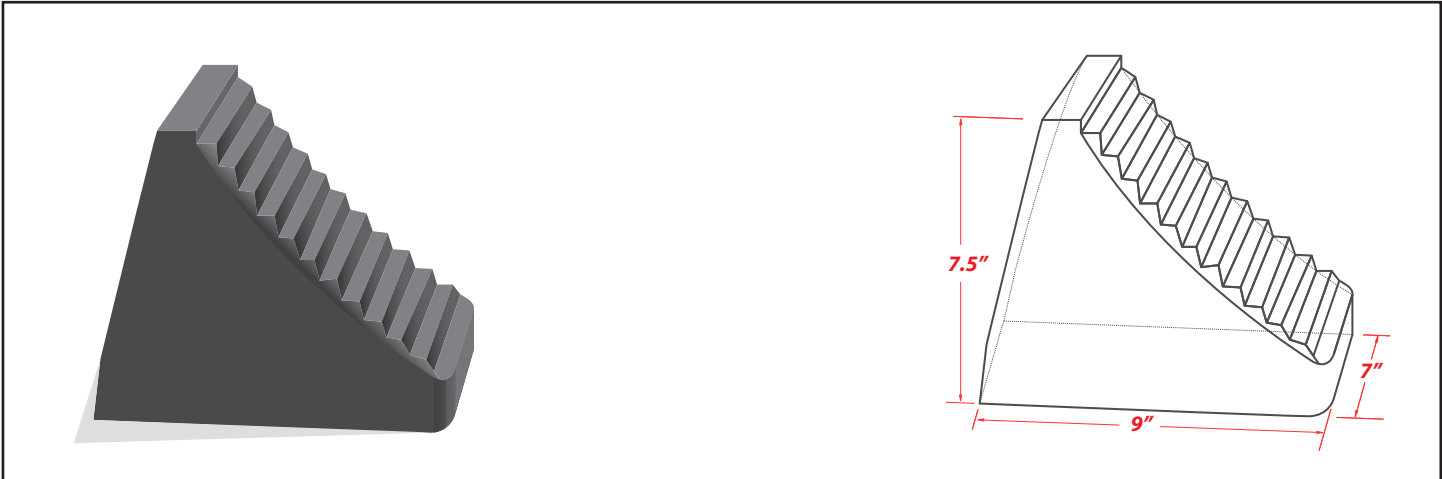

Stock No.	Size	Weight Ea.
WCHF	7.75x9.25x7.25	10.8 lbs.



RHINO
ANTI-FATIGUE MATS

YOU STAND. WE DELIVER.

Industrial Ergonomics®

612-532-6774

sales@Industrial-Ergonomics.com



Copyright © 2021, by Rhino Commercial Mats & Matting. All rights reserved. Printed in the U.S.A. No part of this publication may be reproduced, sorted in a retrieval system or transmitted in any form by any means, whether electronic, mechanical, photocopying, recording or otherwise, without prior written permission of Rhino Commercial Mats & Matting.



TRITAN® DOCK PROTECTORS

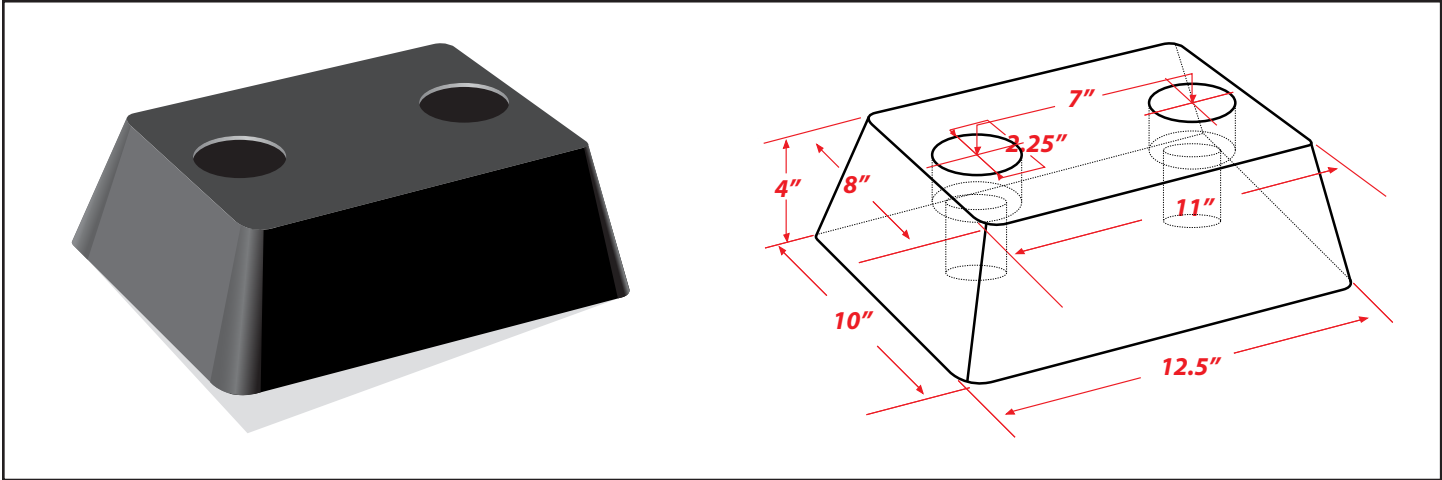

Stock No.	Size	Weight Ea.
NPLF	4x10x12.5	13.4 lbs.

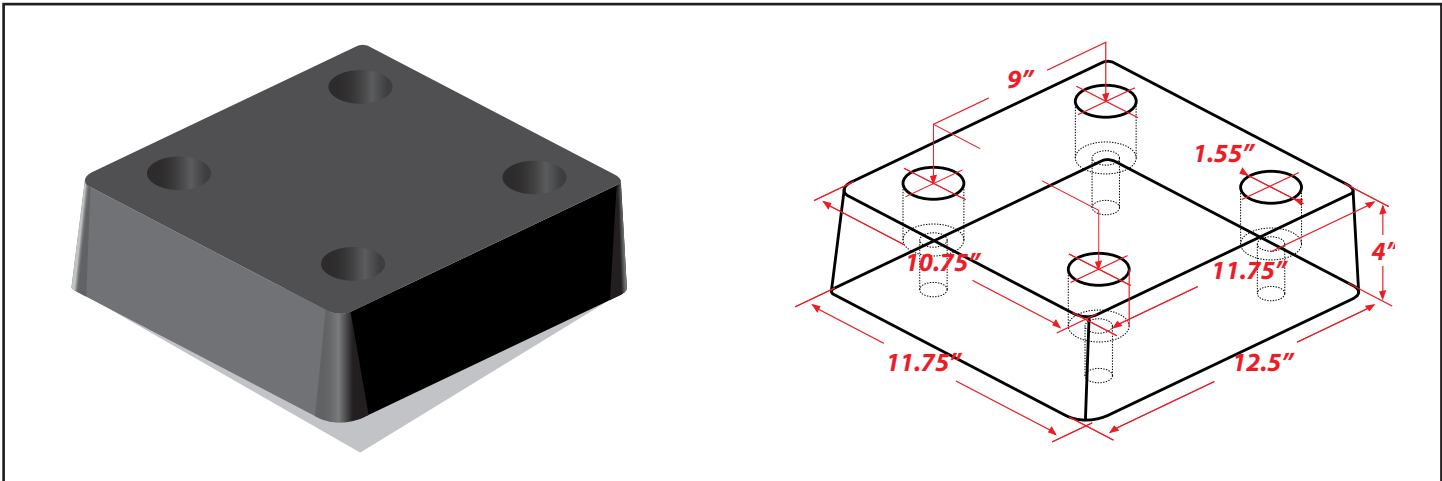

Stock No.	Size	Weight Ea.
NR4F	4x11.75x12.5	20.6 lbs.

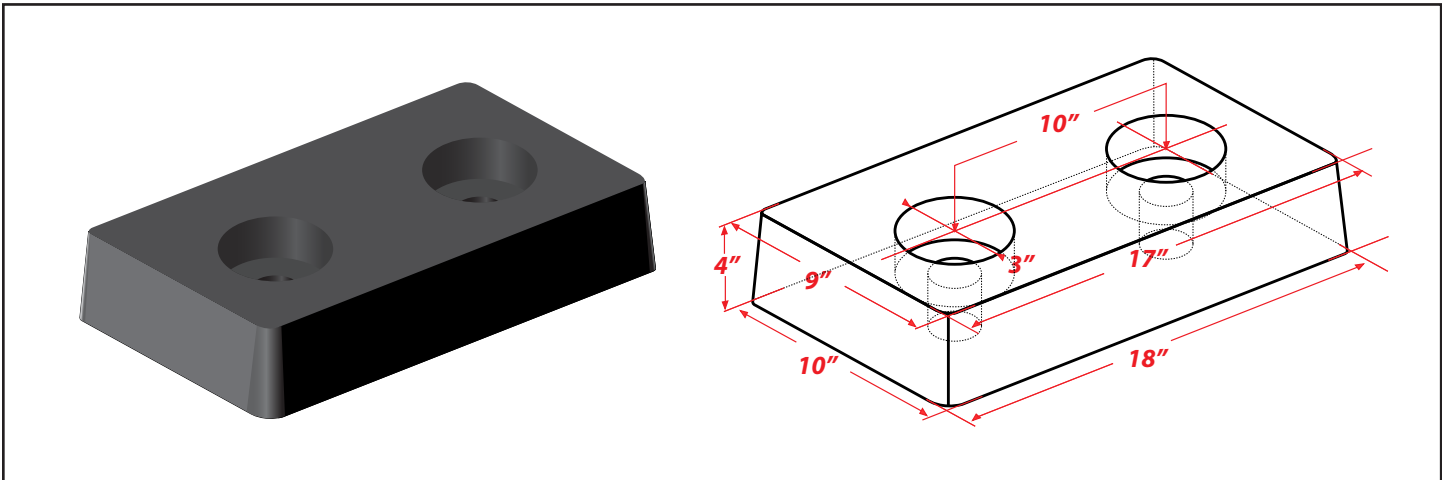

Stock No.	Size	Weight Ea.
PL4F	4x10x18	26.5 lbs.

TRITAN® BUMPERS AND WHEEL CHOCKS

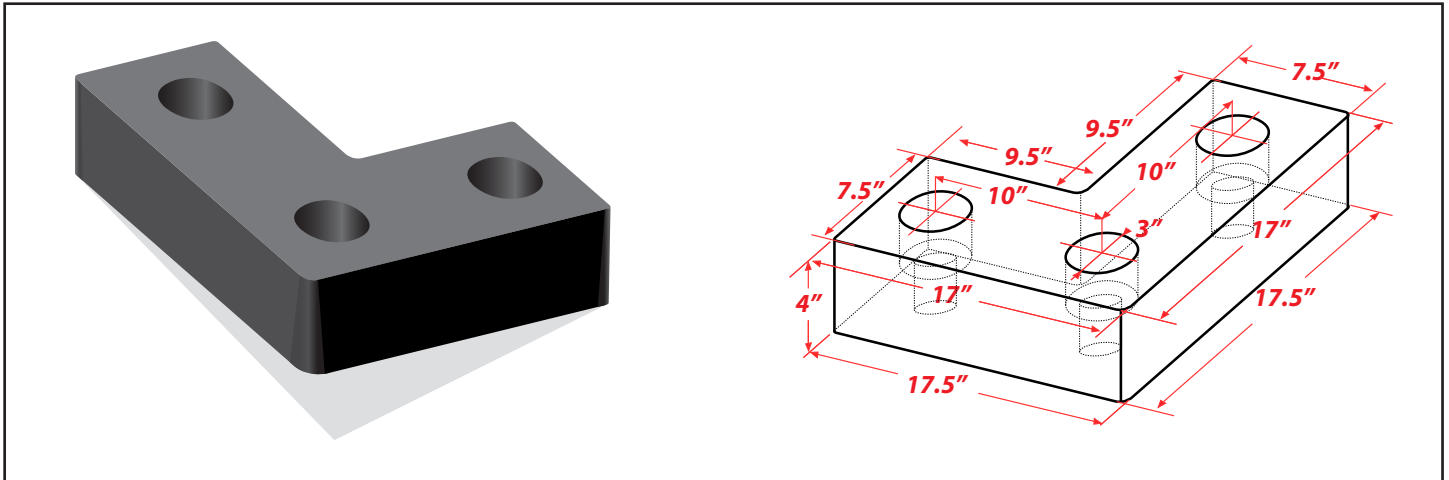

Stock No.	Size	Weight Ea.
RLFF	4x17.5x17.5	34.0 lbs.

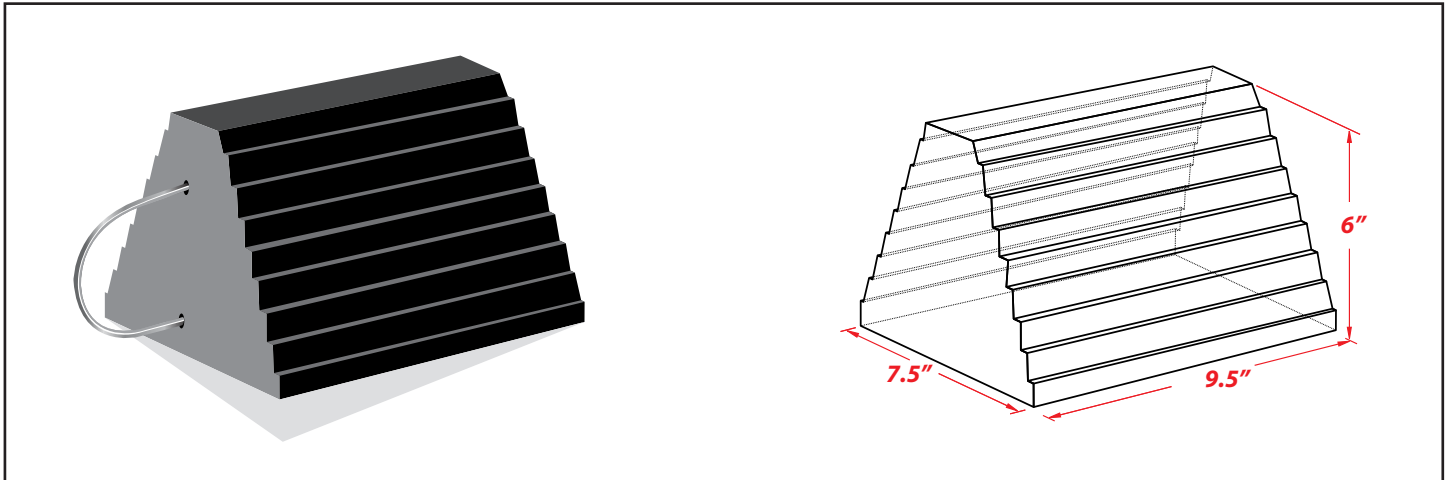

Stock No.	Size	Weight Ea.
CHUF	6x9.5x7.75	9.5 lbs.

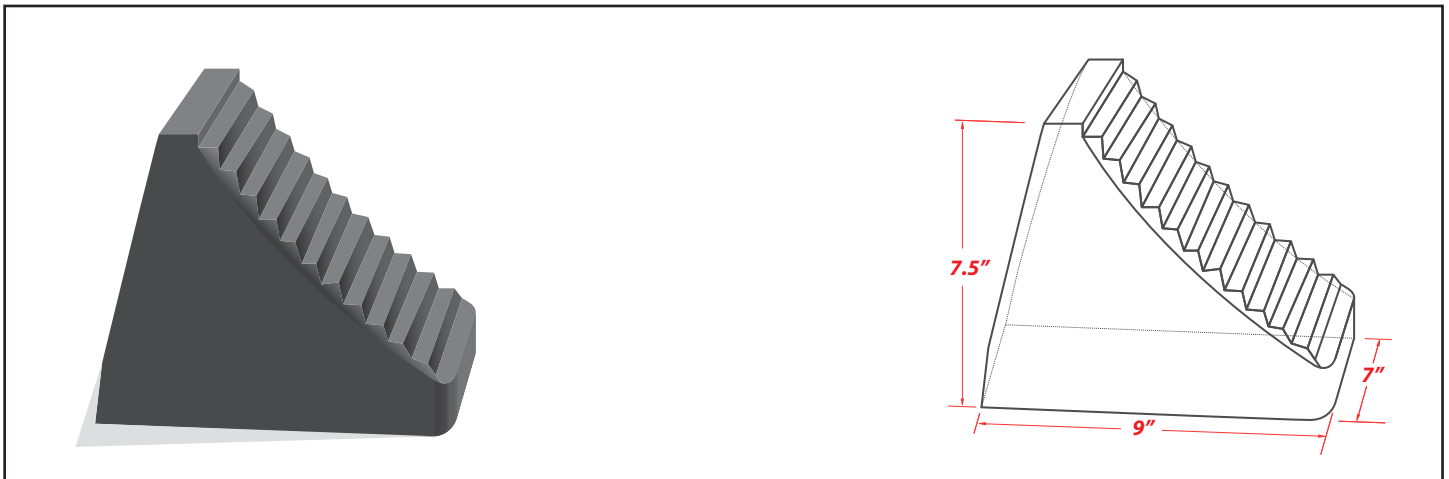

Stock No.	Size	Weight Ea.
WCHF	7.75x9.25x7.25	10.8 lbs.



RHINO
ANTI-FATIGUE MATS

YOU STAND. WE DELIVER.

Industrial Ergonomics®

612-532-6774

sales@Industrial-Ergonomics.com



Copyright © 2021, by Rhino Commercial Mats & Matting. All rights reserved. Printed in the U.S.A. No part of this publication may be reproduced, sorted in a retrieval system or transmitted in any form by any means, whether electronic, mechanical, photocopying, recording or otherwise, without prior written permission of Rhino Commercial Mats & Matting.

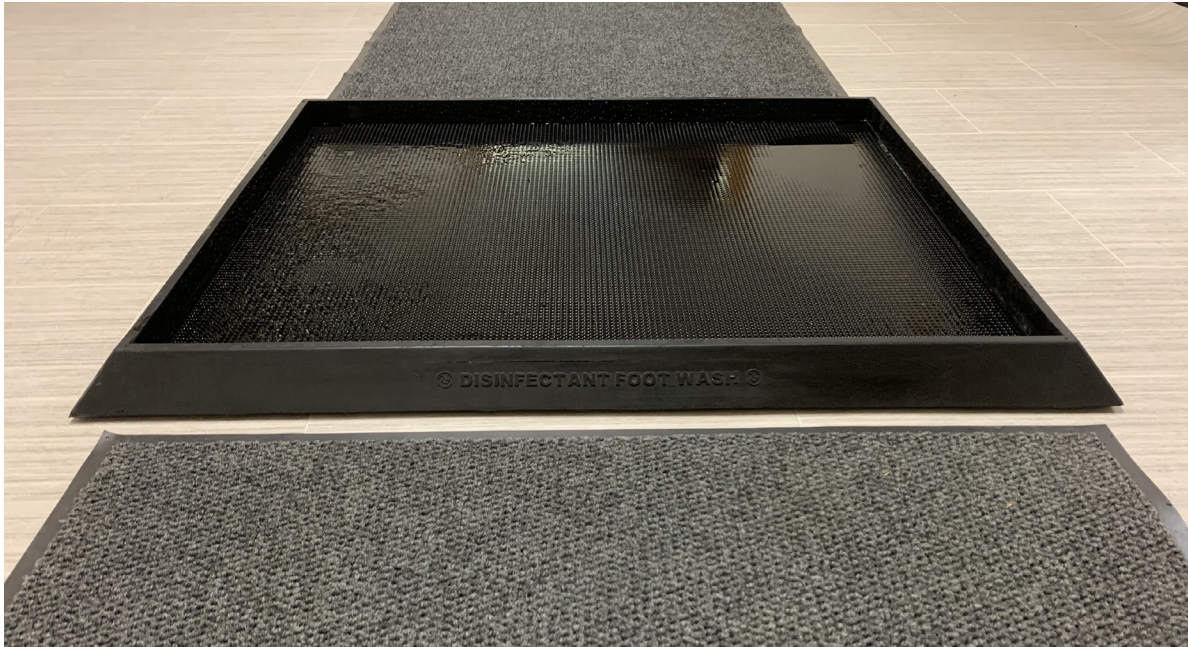

RHINO SHOE WASH

The Rhino Shoe Wash Mat Station sets a new industry benchmark offering a practical, utilitarian and budget priced solution for the robust protection of people and interior environments. The system is ideally suited for commercial and industrial applications including food processing, laboratories, hospitals, catering, medical and hospitality environments.

- The Rhino Decontamination Station features a 2" high water dam design for collection, containment and disinfection of all tracked in foreign materials. This same station does the removal work with 30,000 molded scraper fingertips that are each 0.3" high, offering an automatic scrubbing action that dislodges contaminants from shoes and boots.
- The decontamination station is a compact 32" x 38", yet is sized for a two-step area for best in class results for cleaning and sanitizing. With a non-slip design on the underside of the mat and weighing in at a solid 22 pounds, the Rhino Decontamination Station will not slip.
- Using your existing disinfectant diluted per product specifications, fill the station with a gallon of fluid, just covering the tops of the fingertips. Replenishing your disinfectant in the station is as easy as 1, 2, 3 and can be done as your needs dictate.
- The product is chemically resistant to nearly all disinfectant solutions as it is made from a highly engineered formulation designed specifically for this purpose. The Rhino Disinfectant Station product also demonstrates excellent low temperature flexural properties and is offered with a 5 year warranty.
- The Rhino Decontamination Station is also offered with an optional 2 each set of 3' x 3' drying mats, sold together as one unit or sold separately.

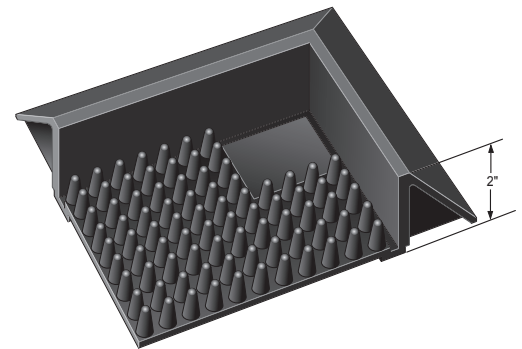
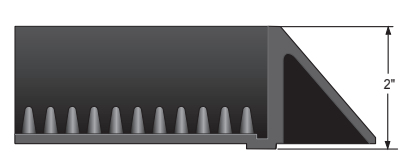

RHINO SHOE WASH

Stock No.	Size	App. Weight.
RSW-3238-2	1 ea 32" x 38" Tray & 2 ea 3'x3'	42.0 lbs.
RSW-3238	1 ea 32" x 38" Tray'	8.0 lbs.

Color: Black, Drying Mat Charcoal.
3/8" Thick.

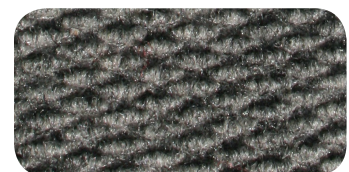

Charcoal Drying Mat

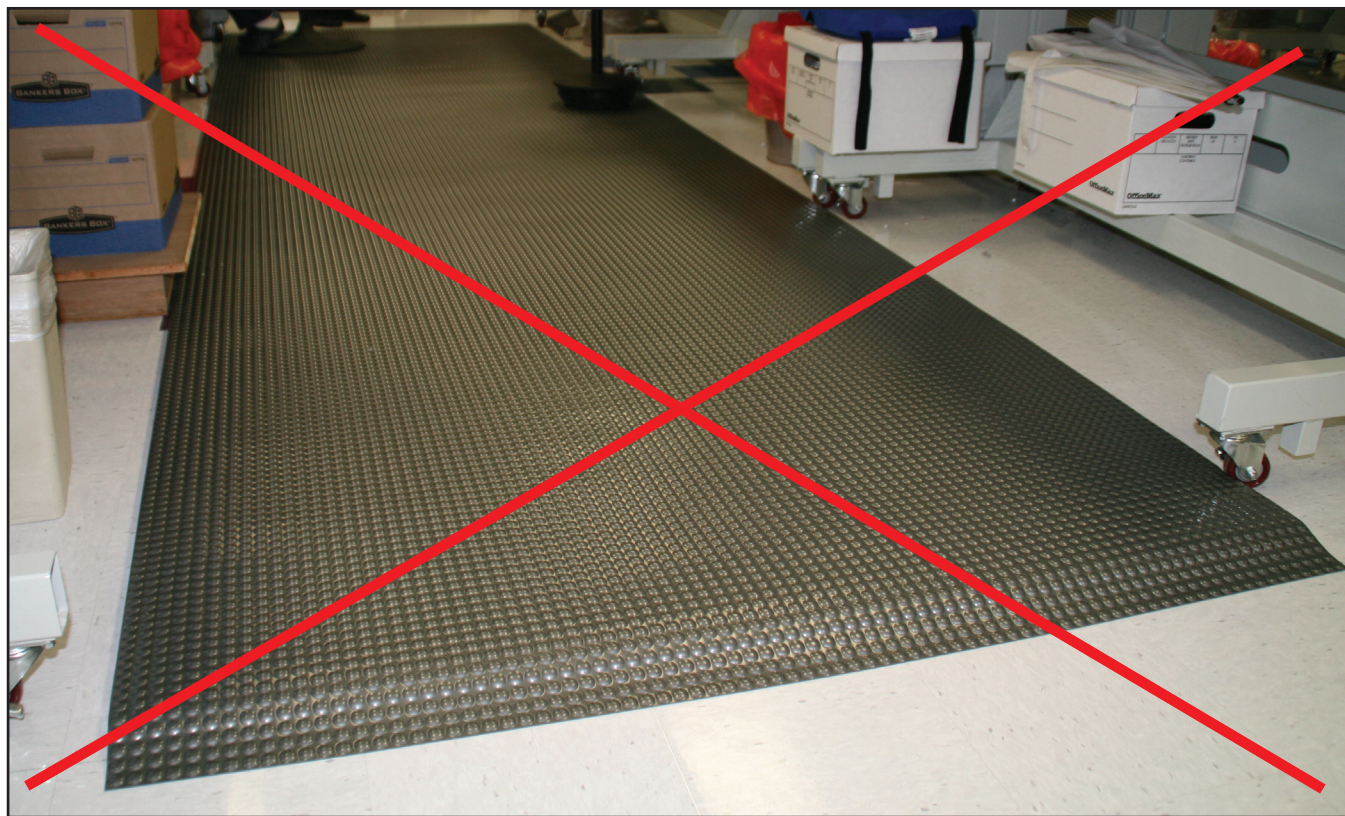

MEGA MAT ANTI-FATIGUE

- Mega Mat is a large format anti-fatigue mat offering a one-piece seamless surface that is scuff-resistant textured and 3.5 millimeters or .140" thick, making the mat almost indestructible. with a 5 year wear surface guarantee..
- Mega Mat suffers no deterioration from weathering and ozone exposure and is self-extinguishing when tested in accordance with FMVSS-302.
- Mega Mat offers excellent durability following exposure to many organic and inorganic chemicals.
- Mega Mat with its closed cell polymeric sponge base produces the incredibly soft and resilient rebound properties needed in a rigorous multi-station work environment.
- Mega Mat is available in two thicknesses, Heavy-Duty is 9/16" and Super-Duty is 15/16" thick.
- Mega Mat is available in stock widths of 72", 96" & 120", up to 75 feet long. Custom widths and configurations can be cut from stock sizes.

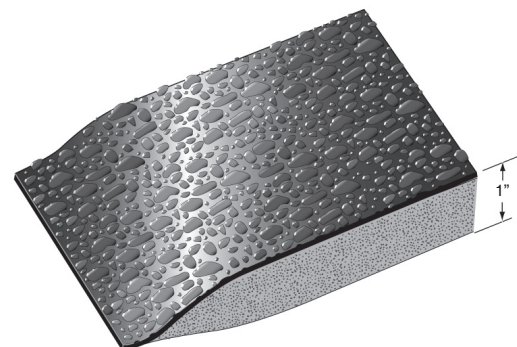
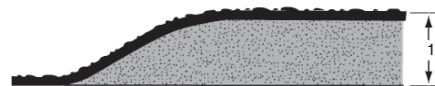
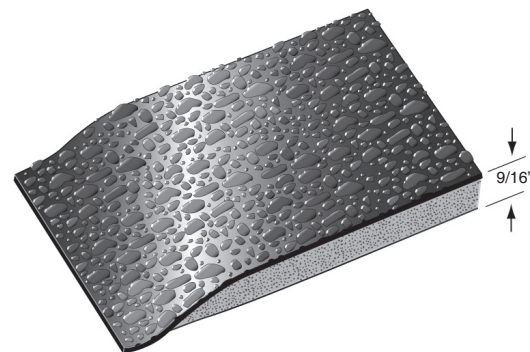
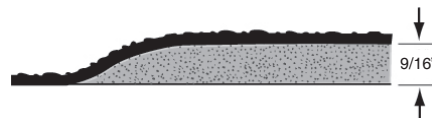

WIDE VISTA Anti Fatigue Mats

Stock No.	Widths	Weight Lin. Ft.	
		9/16"	1"
MM-72	6'	10.0 lbs.	12.0 lbs
MM-96	8'	13.5 lbs	16.0 lbs
MM-120	10'	17.0 lbs	20.0 lbs

Color: Black Only. Cut lengths up to 75'.
9/16" or 1" Thick. (1" add DS to part number)



RHINO DIAMOND STAIR TREADS

- Rhino Diamond stair treads are a practical, utilitarian product for preventing stair related falls.
- For use in Industrial / commercial buildings / residential steps cellars and decks.
- Stair related falls are the second leading cause of accidental injuries, causing more than one million injuries and 12,000 deaths per year, with 60% being residential.
- Rhino Diamond Stair Treads are manufactured with a combination of natural and recycled rubber and are easily cut to size using a utility knife and straight edge.
- Securing with double sided carpet tape offers reliable stability. It also can be removed easily without causing damage to sub-surfaces. If a permanent installation is not wanted, treads can be simply placed on the steps. In many cases the natural traction provided by the rubber is enough to keep the treads in-place. Permanent installation requires a clean substrate, using 2 part epoxy flooring adhesive, applied to both stairs and treads.
- Diamond Treads are 10"X29-3/8"x3/16" thick with a 1" square nose
- Weight: 1.8 lbs each; Color: Black. Simply sweep with a broom using a mild household detergent solution.
- Sold 6 per package.

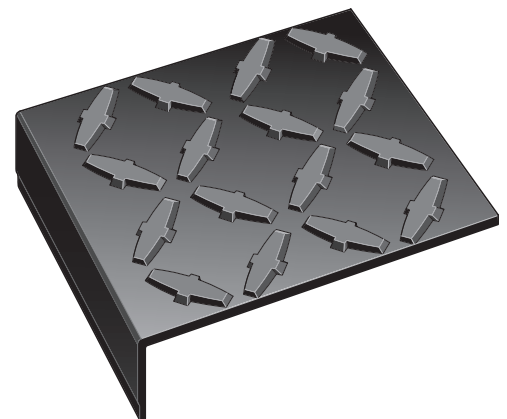
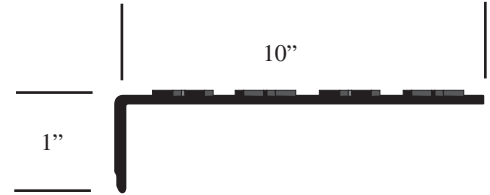

RHINO DIAMOND STAIR TREADS

Stock No.	Size	Weight Ea.
SC-2448	10"X29-3/8"X3/16"	1.8 lbs
Sold in 6 packs		11 lbs
Color: Black only.		





RHINO BAR STAIR TREADS

- Rhino Bar stair treads are a practical, utilitarian product for preventing stair related falls.
- For use in Industrial / commercial buildings / residential steps cellars and decks.
- Stair related falls are the second leading cause of accidental injuries, causing more than one million injuries and 12,000 deaths per year, with 60% being residential.
- Rhino Bar Stair Treads are manufactured with a combination of natural and recycled rubber and are easily cut to size using a utility knife and straight edge.
- Securing with double sided carpet tape offers reliable stability. It also can be removed easily without causing damage to sub-surfaces. If a permanent installation is not wanted, treads can be simply placed on the steps. In many cases the natural traction provided by the rubber is enough to keep the treads in-place. Permanent installation requires a clean substrate, using 2 part epoxy flooring adhesive, applied to both stairs and treads.
- Bar Treads are 10"X29-1/2"x7/32" thick with a 1" square nose
- Weight: 2.2 lbs each; Color: Black. Simply sweep with a broom using a mild household detergent solution.
- Sold 6 per package.

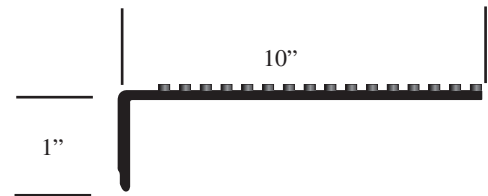

RHINO BAR STAIR TREADS

Stock No.	Size	Weight Ea.
SC-2448	10"X29-1/2"X7/32"	2.2 lbs
Sold in 6 packs		14 lbs
Color: Black only.		





RADOME

- Rhino mats newly developed Low-Pro domed surface delivers the superior ergonomics that can only be achieved with a Bi-Level surface, with smooth surface cleanability.
- The Radome has a near perfect underfoot contour, offers a faster adapting surface, slightly springy feel and delivers premium ergonomics and much needed relief the standing worker deserves.
- Radome is a 7/8" thick polyurethane sponge mat encapsulated in an unbelievably tough and wear resistant 1/8" thick solid polyurethane skin.
- When the job demands standing, there are "no substitutions" for a world class anti-fatigue mat like Radome.
- Sizes available 2'X3', and 3'X5'. Color: Black.

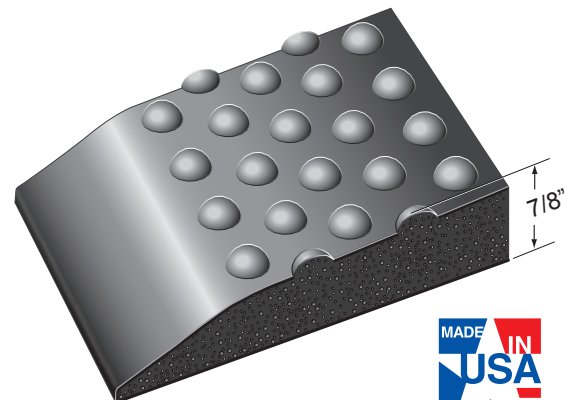

RADOME 7/8"

Stock No.	Size	Weight Ea.
RD-2436	2' x 3'	7.5 lbs.
RD-3660	3' x 5'	17.0 lbs.

Color: Black Only. 7/8" Thick.





Mat Selection Factors

We offer two versions of mats. The selection process for industrial applications is not a one size fits all scenario, so please take a moment to facilitate your own decision making analysis

	<u>Rhino-Craft</u>	<u>Econo-Craft</u>	<u>Import</u>
Wear Surface	Most durable	Most durable	Least durable
Sponge Backing	Nitrile alloy	High density PVC	Low density PVC
Resiliency	Excellent	Good	Sub-standard
Bounce	Excellent	Medium	Poor
Placement Stability	Good	Excellent	Good
Flammability	FMVSS-302	FMVSS-302	Not rated
American Made	Yes	Yes	No
American Warranty	Yes	Yes	No
Warranty Length	5 years	2 years	None
Lay flat Edge	Excellent	Excellent	Sometimes
Tapered sponge bevel	Yes	No	No
Hazardous Content	None	None	Sometimes
Value	Highest	Medium	Lowest
Cost	\$	~10% less than \$	~10% less than \$
Life Cycle Cost	Best	Moderate	Poor

Every one of our mats is proudly manufactured in our Houston facility. Made in America by Americans!